

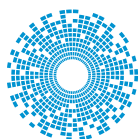

## PWC Series

# Electrical Connectors with Quick-disconnect, double-start Threads

MIL-C-26482, Series I Commercial  
& Military QPL'd



**cinch**  
CONNECTIVITY SOLUTIONS  
a bel group

+1 305.234.1000  
[cinch.com](http://cinch.com)

# PRODUCT INDEX

## PWC Series

---

### Contents

Product Data	2
Nomenclature Guide	3
Cross-Reference	3
Contract Arrangements	4/5
Polarization	6
Panel Mounting Data	7
Printed Circuit Termination	8
Dust Caps	15

Cinch Connectivity Solutions produces high quality products. These products are intended to be used in accordance with the specifications described in this catalog. Any use or application that deviates from the stated operating specifications is not recommended and may be unsafe. A limited warranty is applicable. Except for obligations assumed by Cinch Connectivity Solutions under

warranty, Cinch will be not be liable for any loss, damage, repairs, incidental or consequential damages of any kind, whether or not based upon expressed or implied warranty, contract, negligence, or liability arising from the application or manufacture or repair of these products. This catalog is not a contractual offering; it is for informational purposes only.

# PWC Series

Array Connector Corporation's PWC Connectors offer the answer to your requirements for the most critical electrical circuits. PWC Connectors accommodate almost 3 times as many circuits, size for size, as comparable MS connectors (MIL-C-26482). PWC Connectors incorporate a quick-disconnect, double-start thread main coupling.

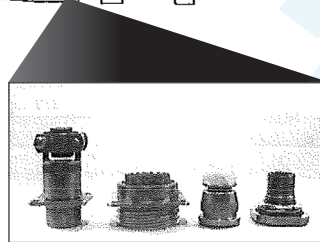
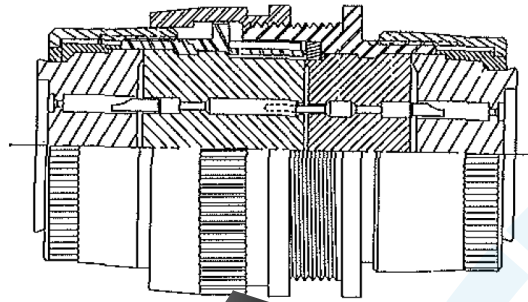

Complete mechanical assistance in both engaging and disengaging. Single keyway and key polarization represents maximum simplicity in a design field proven over years of service.

- Gold plated pin and socket contacts made from high-grade copper alloy
- Closed-entry, probe-proof socket contacts
- Resilient inserts-performance proved in thousands of applications
- Quality-machined components, available in a variety of finishes to meet your application specific requirements



PWC00  
Wall-Mounting Receptacle  
Page 9



PWC01  
Cable-To-Cable Receptacle  
Page 10

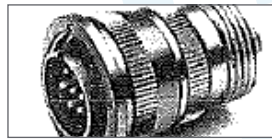

PWC06



PWC07  
Jam Nut Receptacle pages  
13 and 14

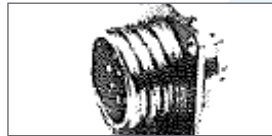

PWC02  
Box-Mounting Receptacle  
Page 11

# Product Data

## Electrical

Contact Termination	(PWC) Solder Pot or PC Tail
Number of Contacts	2 to 55
Wire Size, AWG	12 to 24

Wire Range Accommodations		Insulation 0.0. Limils	
Contact Size	AWG Wire Size	Min.	Max.
20	24, 22 and 20	.060 (1.52)	.083 (2.11)
16	20, 18 and 16	.066 (1.68)	.109 (2.77)
12	14 and 12	.097 (2.46)	.142 (3.61)

### Contact Rating

Contact Size	Rated Amps	Test Current	Max. Millivolt Drop
20	7.5	7.5	55
16	13.0	13.0	49
12	23.0	23.0	42

### Voltage Rating

Altitude	Service Rating	Test Voltage		Max. Working Voltage	
		AC (rms)	DC	AC (rms)	DC
Sea Level	1	1500	2100	600	850
	2	2300	3200	1000	1400
70,000 ft.	1	375	535	300	510
	2	500	770	450	740

## Standard Material and Finishes

Shell (Mil-Std)	Aluminum alloy, conductive yellow chromate over cadmium finish per QQ-P-416. (Consult Factory for Commercial options.)
Insulator	Synthetic rubber
Grommet and Seal	Synthetic rubber
Contacts	Copper alloy, gold plate per MIL-G-45204 type II
Temperature Range	-55°C to +125°C

## Mechanical

Shell Styles	00 - Wall mounting receptacle 01 - Cable in line receptacle 02 - Box mounting receptacle 06 - Straight plug 07 - Jam .nut receptacle
Shell Size	8 thru 24
Polarization/Coupling	Thread A - General duty B - General duty with strain relief C - Pressurized E - Grommet seal F - Grommet seal with strain relief J - Straight backshell with O-ring seal JF - Same as MIL-C-26482 J available in commercial PWC only N - No back end, no termination hardware P - Poltled
Service Classes	

ACC and are registered trademarks of Array Connector Corporation

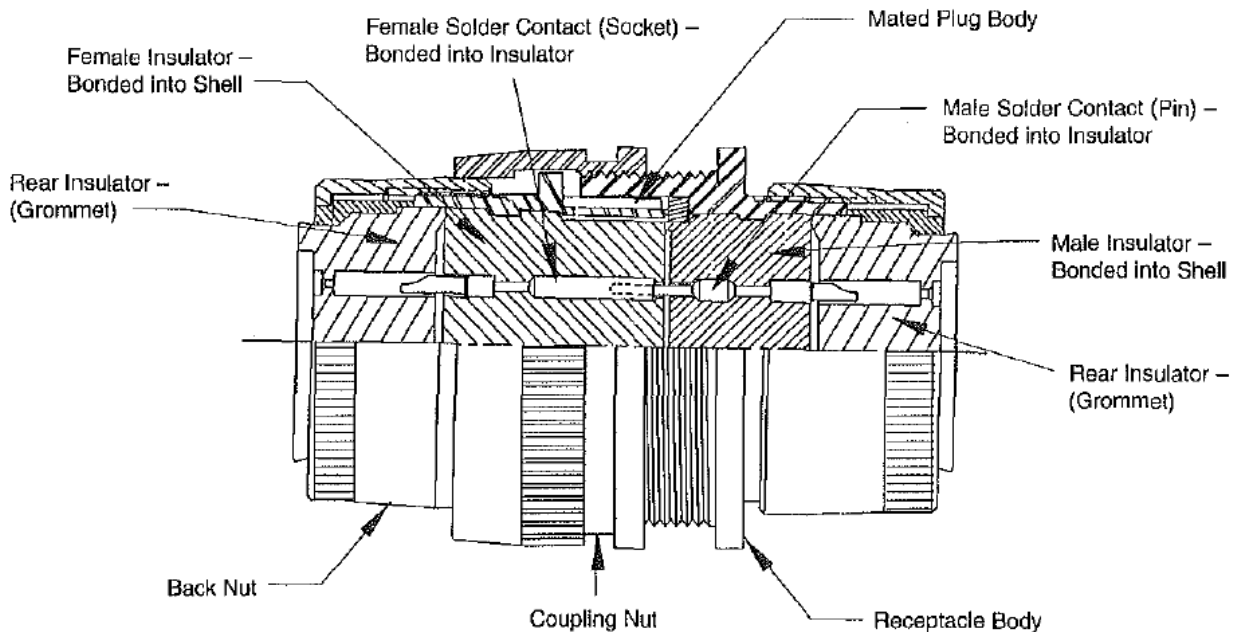

Array Connector Corporation produces high quality products. These products are intended to be used in accordance with the specifications described in this catalog. Any use or application that deviates from the stated operating specifications is not recommended and may be unsafe. A limited warranty is applicable. Except for obligations assumed by Array Connector Corporation under warranty, Array will not be liable for any loss, damage, repairs, incidental or consequential damages of any kind, whether or not based upon expressed or implied warranty, contract, negligence, or liability arising from the application or manufacture or repair of these products. This catalog is not a contractual offering; it is for informational purposes only.

# Nomenclature Guide

Example      PWC      01      F      22      -      55      C      P      Y      'A612  
                  PWC      06      E      22      -      55

**SERIES PREFIX**  
PWC =ARRAY

**SHELL STYLE**

- 00 = wall mount receptacle
- 01 = cable to cable receptacle
- 02 = box mount receptacle
- 06 = straight plug
- 07 = jam nut mount receptacle
- 08 = 90° plug

**CONTACT ARRANGEMENT**  
(See pages 4 and 5)

SHELL SIZE 8 thru 22 available

**SERVICE TYPE (Class)**

- A = general duty
- B = general duty with strain relief
- C = pressurized
- E = grommet seal
- F = same as E with strain relief
- J = straight back shell with O' ring seal
- JF = same as J with strain relief
- P = potting shell
- N = no back end, no termination hardware

**C = Industrial Crimp Contacts Option (Consult factory)**

**CONTACT TYPE**

- P = pins
- S = sockets

**MODIFICATION CODES**

- A602 = Black Anodize Plating
- A610 = Aluminate Plating
- A612 = Electroless Nickel Plating
- A617 = Tin Plating
- F602 = Clinch Nuts
- M901 = Stainless Steel Construction

\*For modification codes not listed, consult factory.

**POLARIZATION**  
(See Chart, page 6)

## Cross Reference

ARRAY	BENDIX
PWC00A	PC00A
PWC00B	PC00A**(SR)
PWC00E	PC00E
PWC00F	PC0E**(SR)
PWC00J	PC00W
PWC00JF	-
PWC00P	PC00P
PWC01A	PC01A
PWC01B	PC01A**(SR)
PWC01E	PC01E
PWC01F	PC01 E**(SR)
PWC01J	PC01W
PWC01JF	-
PWC02A	PC02A

ARRAY	BENDIX
PWC02E	PC02E
PWC02A	PC02A
PWC07C	PC07C
PWC07E	PC07E
PWC07F	PC07E-(SR)
PWC07P	PC06P
PWC06A	PC06A
PWC06B	PC06A**(SR)
PWC06E	PC06E
PWC06F	PC06E**(SR)
PWC06J	PC06W
PWC06JF	-
PWC06P	PC06P

# Contact Arrangement (Engaging Face of Pin Insert)

(For contact arrangements not shown, contact factory)

08

2  
2 No. 20 Contacts

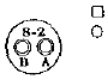

3  
3 No. 20 Contacts



33  
3 No. 20 Contacts



4  
4 No. 20 Contacts



10

6  
6 No. 20 Contacts



98  
6 No. 20 Contacts



7  
7 No. 20 Contacts

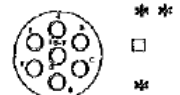

12

3  
3 No. 16 Contacts

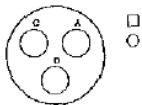

8  
8 No. 20 Contacts

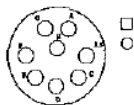

10  
10 No. 20 Contacts

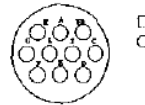

14  
14 No. 20 Contacts

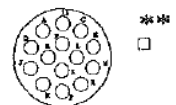

14

5  
5 No. 16 Contacts

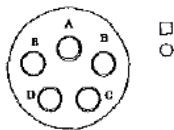

8  
4 No. 20 Contacts  
4 No. 12 Contacts

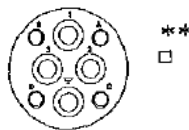

12  
4 No. 16 Contacts  
8 No. 20 Contacts

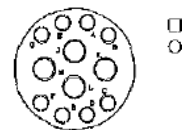

15  
1 No. 16 Contact  
14 No. 20 Contacts

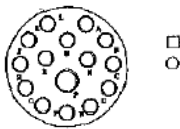

18  
18 No. 20 Contacts

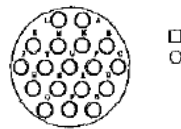

19  
19 No. 20 Contacts

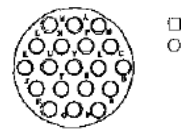

16

8  
8 No. 16 Contacts

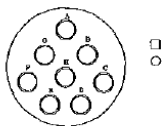

23  
1 No. 16 Contact  
22 No. 20 Contacts

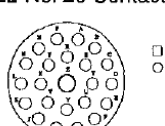

26  
26 No. 20 Contacts

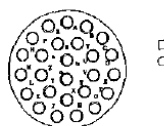



# Contact Arrangement (Engaging Face of Pin Insert)

**18**

<p>11 11 No. 16 Contacts</p>	<p>32 32 No. 20 Contacts</p>	<p>30 30 No. 20 Contacts</p>
----------------------------------	----------------------------------	----------------------------------

---

**20**

<p>16 16 No. 16 Contacts</p>	<p>24 24 No. 20 Contacts</p>	<p>25 25 No. 20 Contacts</p>
<p>27 27 No. 20 Contacts</p>	<p>39 2 No. 16 Contacts 37 No. 20 Contacts</p>	<p>41 41 No. 20 Contacts</p>

---

**22**

<p>21 21 No. 16 Contacts</p>	<p>32 32 No. 20 Contacts</p>	<p>34 34 No. 20 Contacts</p>
<p>41 14 No. 16 Contacts 27 No. 20 Contacts</p>	<p>55 55 No. 20 Contacts</p>	<p>** Commercial arrangement.                  □ Available with solder or straight PC contacts.                  ○ MIL-C-26482 Series 1 Contact arrangements, per MIL-STD-1669.                  * Consult with factory.</p>

---

**24** Consult Array factory for shell size 24 versions.

---

# Polarization

The diagrams indicate alternate insert position. The five positions (W, X, Y, Z and Normal) differ in degree of rotation for various size and layouts. The exact angle of rotation for the combinations are listed in the table below. Use letters W, X, Y, Z to specify alternate polarizations. For normal polarization, no indication is required.

## Engaging Face-Pin Inserts

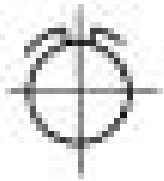

Position N (Normal)

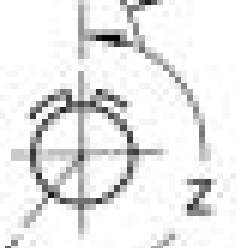
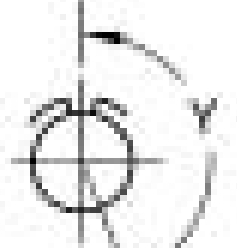
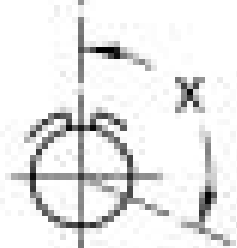
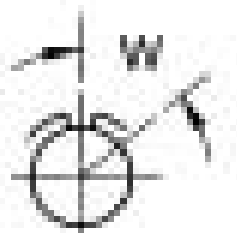

Shell Size	Layout	Position			
		W	X	Y	Z
8	2	58°	122°	-	-
	3	60°	210°	-	-
	4	45°	-	-	-
	33	90°	-	-	-
10	6	90°	-	-	-
	98	90°	180°	240°	270°
12	3	-	-	180°	-
	8	90°	112°	203°	292°
	10	60°	155°	270°	295°
	14	-	-	-	-
14	5	40°	90°	184°	273°
	8	-	-	-	-
	12	43°	90°	-	-
	15	17°	110°	155°	234°
	18	15°	90°	180°	270°
	19	30°	165°	315°	-
	22	45°	-	-	-

Shell Size	Layout	Position			
		W	X	Y	Z
16	8	54°	152°	180°	331°
	23	158°	270°	-	-
	26	60°	-	275°	338°
18	11	62°	119°	241°	340°
	32	85°	138°	222°	265°
20	16	238°	318°	333°	347°
	24	70°	145°	215°	290°
	27	72°	144°	216°	288°
	39	63°	144°	252°	333°
	41	45°	126°	225°	-
22	21	16°	135°	175°	349°
	41	39°	135°	264°	-
	55	30°	142°	226°	314°

NOTE: For polarization data for other contact arrangements, consult factory.



# Panel Mounting Data

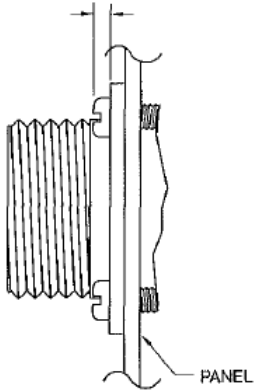

## Max Panel & Screw Heads

SHELL SIZE	PW00	PW02
8		
10		
12	0.087	0.087
14		
16		
18		
20	0.212	0.212
22		

Note: All dimensions relate to distance in front of flange required for proper mating.

# Series PW Panel Cutout Dimensions

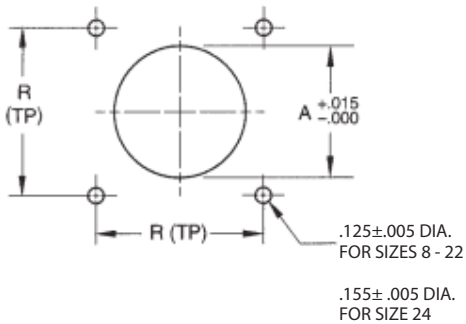

## Wall & Box Mounting Receptacle 00, 02

Square flange PWC receptacles are normally front panel mounted, using dimensions indicated. Hole location "R" is true position and is located within .005 dia. of (TP).

SHELL SIZE	INCHES		MILLIMETERS	
	A	R	A	R
8	.479	.594	12.17	15.08
10	.603	.719	15.32	18.28
12	.730	.812	18.54	20.61
14	.855	.906	21.72	23.00
16	.979	.969	24.87	24.60
18	1.103	1.062	28.02	27.00
20	1.223	1.156	30.56	29.36
22	1.350	1.250	33.78	31.75

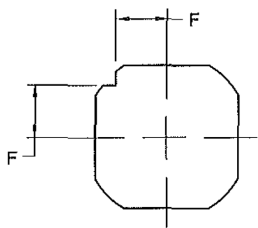

## Jam Nut Receptacle 07

PWC series jam nut receptacle mounts in a round hole and can be pinned to prevent rotation.

SHELL SIZE	INCHES	MILLIMETERS
	F ± .010	F ± .254
8	.331	8.41
10	.375	9.53
12	.442	11.23
14	.486	12.34
16	.530	13.46
18	.573	14.55
20	.641	16.28
22	.685	17.40

# Printed Circuit Termination

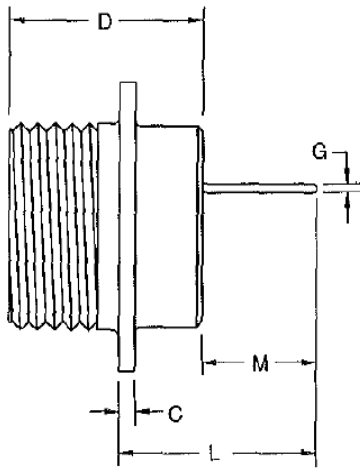

PW02

Note: to define PC tail length(s), specify either "L" or "M" and "G" dimensions.

## Recommended PC Tail Diameter "G"

CONTACT SIZE	DIAMETER
16 gauge	.040
20 gauge	.030

Other dimensions available. Consult with factory

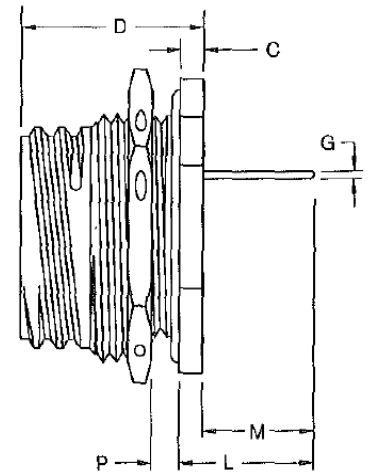

PW07

## PW02 - Shell Dimensions

SHELL SIZE	C±.016	D+.005 -.015	Customer to Specify		
			G±.001	L	M
8	.062	.725			
10	.062	.725			
12	.062	.725			
14	.062	.725			
16	.062	.725			
18	.062	.725			
20	.094	.906			
22	.094	.906			

## PW07 - Shell Dimensions

SHELL SIZE	C±.020	DMAX.	P		Customer to Specify		
			MIN.	MAX.	G±.001	L	M
8	.125	.859	.062	.125			
10	.125	.859	.062	.125			
12	.125	.859	.062	.125			
14	.125	.859	.062	.125			
16	.125	.859	.062	.125			
18	.125	.859	.062	.125			
20	.156	1.078	.062	.250			
22	.156	1.078	.062	.250			

Array Connector Corporation stocks a wide range of contacts for printed circuit board mounting in a variety of length and diameter. The PC types PWC02 and PWC07 (with printed circuit termination) mate with all PWC plugs. They are competitively priced with the solder version, and a substantial savings can be realized when terminated by wave or reflow soldering.

If you require special plating (other than cadmium) or other modifications (i.e., clinch nuts), please advise requirements.

Array can also supply these connectors with custom flex circuitry attached. Please discuss your requirements with your local sales representative.

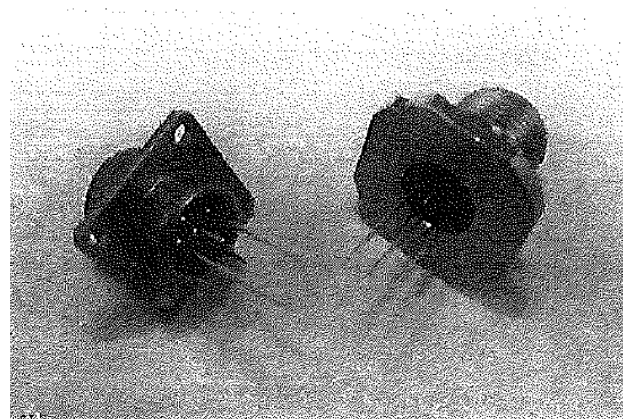

Combinations of different PC tail lengths can be provided.

# Series PWCOO Wall Mount Receptacle

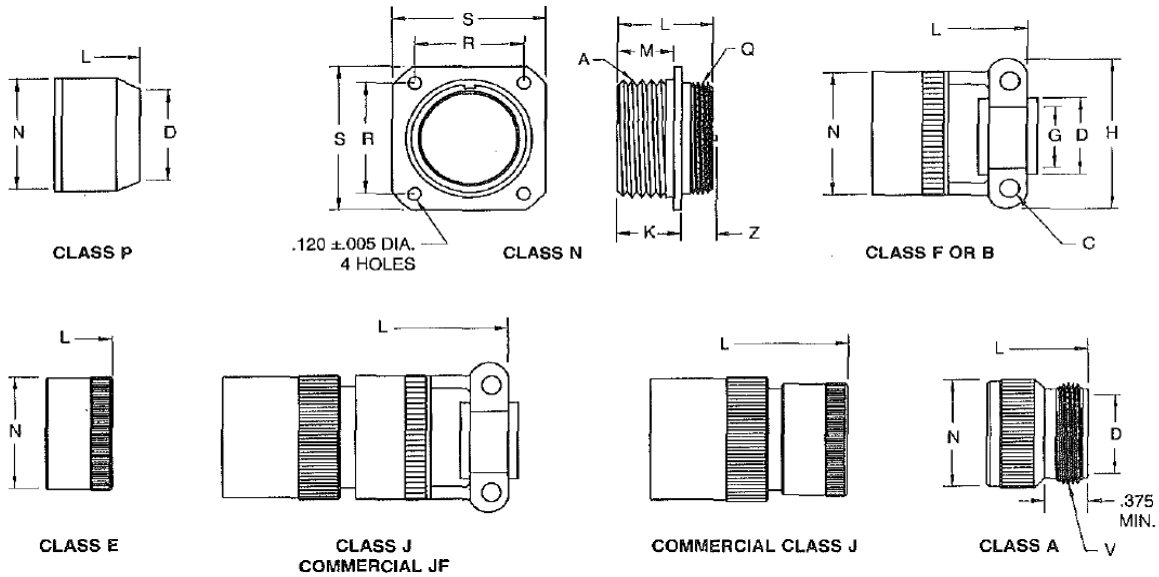

Note: L = Total connector length including cable accessory.

SHELL SIZE	RECEPTACLE FRONT VIEW		RECEPTACLE SIDE VIEW						CLASS A			
	R±.005	S	A THREAD CLASS 2A	K MAX.	L MAX.	M +.000 -.010	Q THREAD CLASS2A	Z MAX.	D MIN.	N MIN.	L MAX.	V THREAD CLASS 2A
8	.594	.812	.5000 OS	.490	.875	.416	.4375-28 UNEF	.466	.297	.590	1.528	.5000-28 UNEF
10	.719	.938	.6250 OS	.490	.875	.416	.5625-24 UNEF	.466	.421	.717	1.528	.6250-24 UNEF
12	.612	1.031	.7500 OS	.490	.875	.416	.6875-24 UNEF	.466	.546	.834	1.528	.7500-20 UNEF
14	.906	1.125	.8750 OS	.490	.875	.416	.8125-20 UNEF	.466	.663	.970	1.528	.8750-20 UNEF
16	.969	1.219	1.0000 OS	.490	.875	.416	.9375-20 UNEF	.466	.787	1.088	1.528	1.0000-20 UNEF
18	1.062	1.312	1.125008	.490	.875	.416	1.0625-18 UNEF	.466	.879	1.216	1.528	1.1875-18UNEF
20	1.156	1.438	1.2500 OS	.584	1.031	.479	1.1875-18 UNEF	.527	1.014	1.332	1.588	1.1875-18 UNEF
22	1.250	1.562	1.3750 OS	.584	1.031	.479	1.3125-18 UNEF	.527	1.135	1.460	1.588	1.4375-18 UNEF

SHELL SIZE	CLASS FOR B			CLASS E		CLASS P		CLASS JF	CLASSJ				
	C THREAD	D MIN.	G DIA.	H MAX.	L MAX.	N MAX.	L MAX.	N MAX.	D MIN.	L MIN.	N MAX.	L MAX.	L MAX.
8	6-32	.240	.125	.812	1.750	.550	1.250	.560	.317	1.406	.608	2.271	1.781
10	6-32	.302	.188	.875	1.750	.675	1.250	.685	.434	1.406	.734	2.271	1.781
12	6-32	.428	.312	1.000	1.750	.803	1.250	.813	.548	1.406	.858	2.411	1.921
14	6-32	.552	.375	1.125	1.750	.920	1.250	.930	.673	1.406	.984	2.599	2.109
16	6-32	.615	.500	1.188	1.882	1.047	1.250	1.057	.798	1.406	1.110	2.943	2.328
18	8-32	.740	.625	1.438	1.882	1.165	1.250	1.175	.899	1.406	1.234	3.172	2.562
20	8-32	.740	.625	1.438	2.071	1.290	1.434	1.301	1.024	1.562	1.360	3.610	3.000
22	8-32	.928	.750	1.719	2.071	1.418	1.434	1.430	1.149	1.562	1.484	3.766	3.156

+1 305.234.1000  
cinch.com

# Series IPWC01 Cable-to-Cable Receptacle

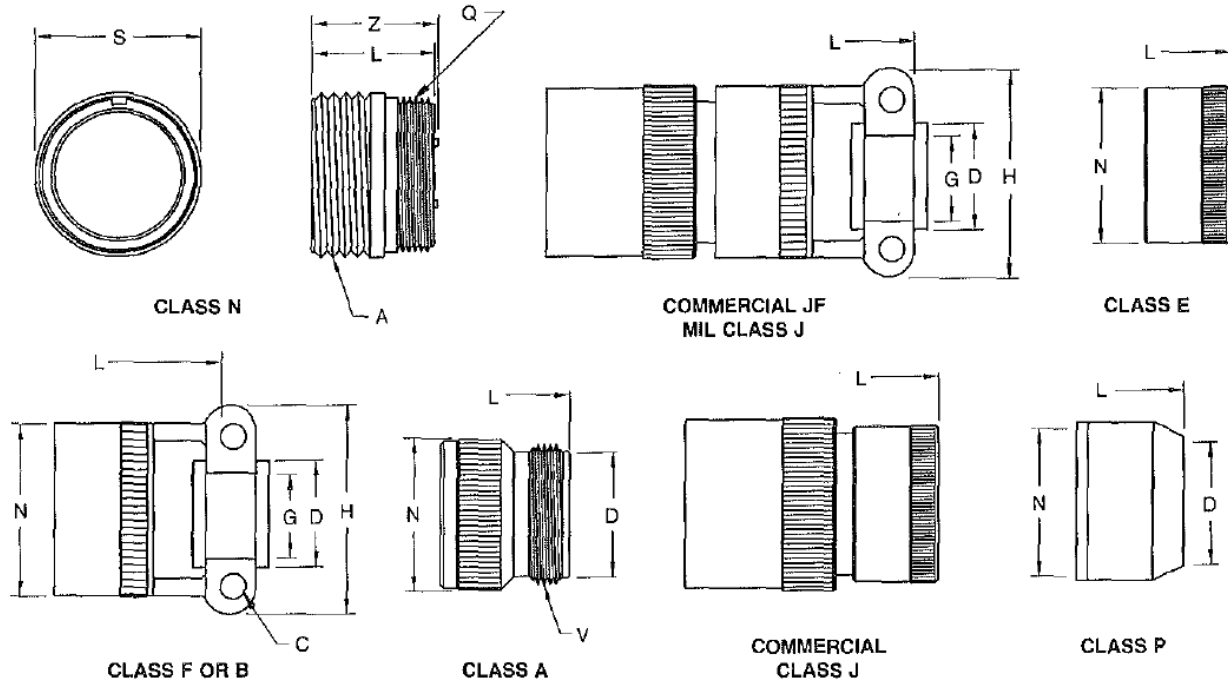

Note: L = Total connector length including cable accessory.

SHELL SIZE	PLUG FRONT VIEW		RECEPTACLE SIDE VIEW			CLASS A			
	S MAX.	A THREAD CLASS 2A	L MAX.	Z MAX.	Q THREAD CLASS 2A	D MIN.	L MAX.	N MAX.	V THREAD CLASS 2A
8	.570	.5000 DS	.875	.924	.4375-28 UNEF	.297	1.518	.590	.5000-28 UNEF
10	.697	.6250 DS	.875	.924	.5625-24 UNEF	.421	1.518	.717	.6250-24 UNEF
12	.814	.7500 OS	.875	.924	.6875-24 UNEF	.546	1.518	.834	.7500-20 UNEF
14	.950	.8750 DS	.875	.924	.8125-20 UNEF	.663	1.518	.970	.8750-20 UNEF
16	1.068	1.0000 OS	.875	.924	.9375-20 UNEF	.787	1.518	1.088	1.0000-20 UNEF
18	1.196	1.125008	.875	.924	1.0625-18 UNEF	.879	1.518	1.216	1.1875-18 UNEF
20	1.312	1.2500 OS	1.031	1.081	1.1875-18 UNEF	1.014	1.578	1.332	1.1875-18 UNEF
22	1.440	1.3750 OS	1.031	1.081	1.3125-18 UNEF	1.135	1.578	1.460	1.4375-18 UNEF

SHELL SIZE	CLASS FOR B			CLASS E			CLASS P		CLASS JF	CLASS J			
	C THREAD	D MIN.	G DIA.	H MAX.	L MAX.	N MAX.	L MAX.	N MAX.	D MIN.	L MIN.	N MAX.	L MAX.	L MAX.
8	6-32	.240	.125	.812	1.740	.550	1.250	.560	.317	1.406	.608	2.271	1.781
10	6-32	.302	.188	.875	1.740	.675	1.250	.685	.434	1.406	.734	2.271	1.781
12	6-32	.428	.312	1.000	1.740	.803	1.250	.813	.548	1.406	.858	2.411	1.921
14	6-32	.552	.375	1.125	1.740	.920	1.250	.930	.673	1.406	.984	2.599	2.109
16	6-32	.615	.500	1.188	1.872	1.047	1.250	1.057	.798	1.406	1.110	2.943	2.328
18	8-32	.740	.625	1.438	1.872	1.165	1.250	1.175	.899	1.406	1.234	3.172	2.562
20	8-32	.740	.625	1.438	2.061	1.290	1.434	1.301	1.024	1.562	1.360	3.610	3.000
22	8-32	.928	.750	1.719	2.061	1.418	1.434	1.430	1.149	1.562	1.484	3.766	3.156



# Series PWC02 Box Mount Receptacle

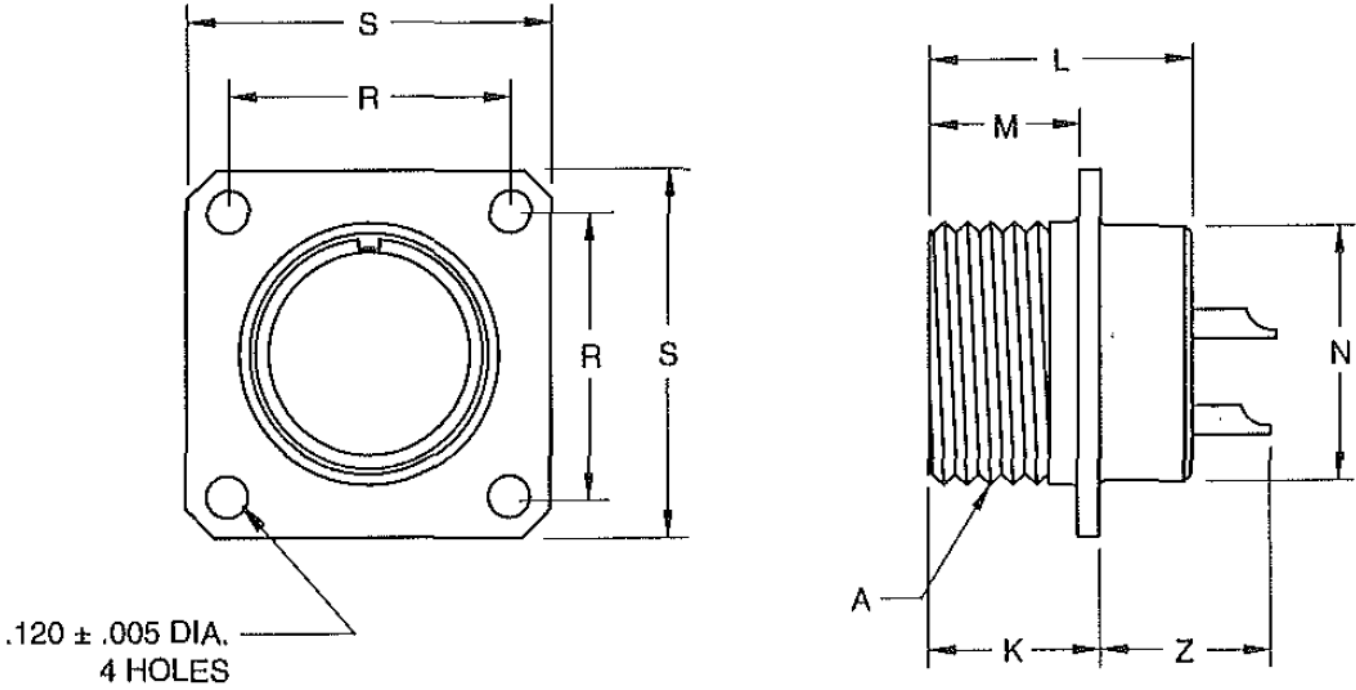

For PC tail configurations, see page 15.

### Dimensions in Inches

SHELL SIZE	R±.005	S	A THREAD CLASS 2A	K +.020 -.010	L MAX.	M +.010 -.000	N MAX.	Z MAX.
10	.594	.812	.5000 DS	.469	.801	.406	.449	.466
12	.719	.938	.6250 DS	.469	.801	.406	.573	.466
14	.812	1.031	.7500 DS	.469	.801	.406	.699	.466
16	.906	1.125	.8750 DS	.469	.801	.406	.823	.466
18	.969	1.219	1.0000 DS	.469	.801	.406	.949	.466
20	1.062	1.312	1.1250DS	.469	.801	.406	1.073	.466
22	1.156	1.438	1.2500 DS	.562	.988	.469	1.199	.527
22	1.250	1.562	1.3750 DS	.562	.988	.469	1.323	.527

# Series IPWC06 Straight Plug

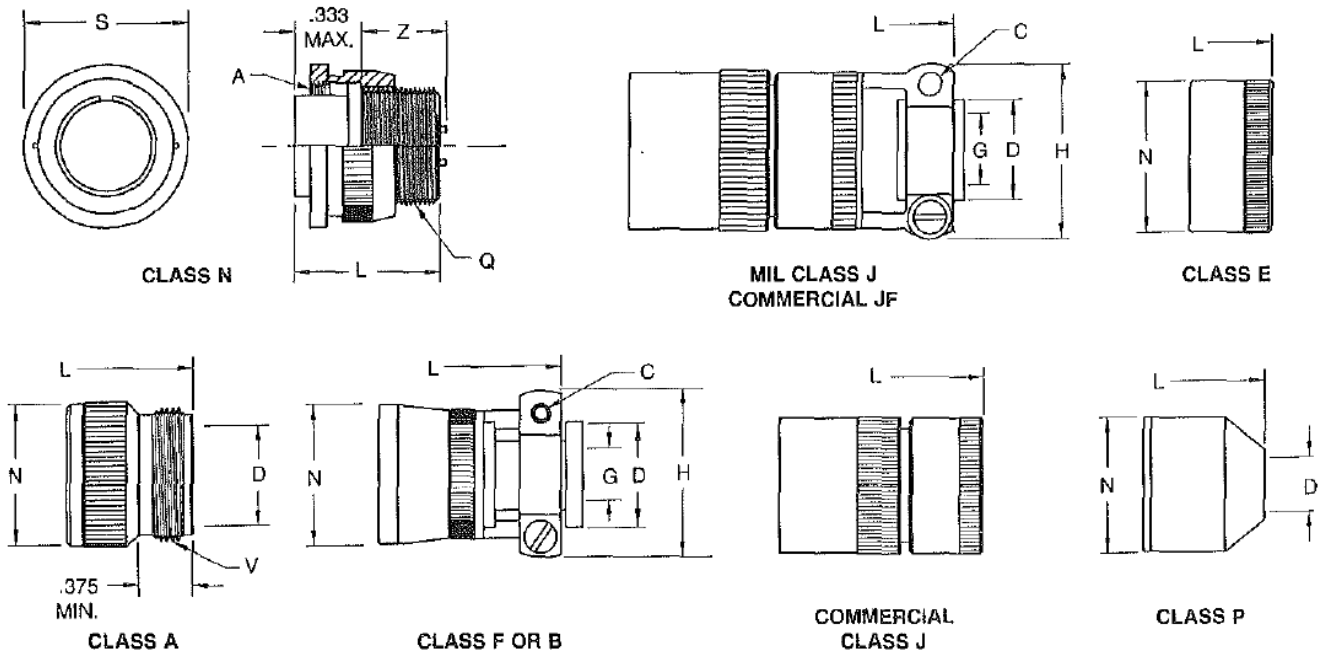

SHELL SIZE	PLUG FRONT VIEW		CLASS N				CLASS A		
	S MAX.	L MAX.	Q THREAD CLASS2A	Z MAX.	A THREAD CLASS2A	D MIN.	L MAX.	N MAX.	V THREAD CLASS 2A
8	.729	.875	.4375-28 UNEF	.627	.5000 OS	.297	1.534	.590	.5000-28 UNEF
10	.854	.875	.5625-24 UNEF	.627	.6250 OS	.421	1.534	.717	.6250-24 UNEF
12	.979	.875	.6875-24 UNEF	.627	.7500 OS	.546	1.534	.834	.7500-20 UNEF
14	1.104	.875	.8125-20 UNEF	.627	.8750 OS	.663	1.534	.972	.8750-20 UNEF
16	1.229	.875	.9375-20 UNEF	.627	1.0000 OS	.787	1.534	1.088	1.0000-20 UNEF
18	1.354	.875	1.0625-18 UNEF	.627	1.1250 OS	.879	1.534	1.216	1.1875-18 UNEF
20	1.478	1.031	1.1875-18 UNEF	.783	1.2500 OS	1.014	1.613	1.332	1.1875-18 UNEF
22	1.604	1.031	1.3125-18 UNEF	.783	1.3750 OS	1.135	1.613	1.460	1.4375-18 UNEF

SHELL SIZE	CLASS FOR B						CLASS E			CLASS P		CLASS JF	CLASS J
	C THREAD	D MIN.	G DIA.	H MAX.	L MAX.	N MAX.	L MAX.	N MAX.	D MIN.	L MIN.	N MAX.	L MAX.	L MAX.
8	6-32	.240	.125	.812	1.740	.550	1.250	.560	.317	1.406	.608	2.271	1.781
10	6-32	.302	.188	.875	1.740	.675	1.250	.685	.434	1.406	.734	2.271	1.781
12	6-32	.428	.312	1.000	1.740	.803	1.250	.813	.548	1.406	.858	2.411	1.921
14	6-32	.552	.375	1.125	1.740	.920	1.250	.930	.673	1.406	.984	2.599	2.109
16	6-32	.615	.500	1.188	1.882	1.047	1.250	1.057	.978	1.406	1.110	2.943	2.328
18	8-32	.740	.625	1.438	1.872	1.165	1.250	1.175	.899	1.406	1.234	3.172	2.562
20	8-32	.740	.625	1.438	2.061	1.290	1.434	1.301	1.024	1.562	1.360	3.610	3.000
22	8-32	.928	.750	1.719	2.061	1.418	1.434	1.430	1.149	1.562	1.484	3.766	3.156

# Series PWC07 AJC Jam Nut Receptacle

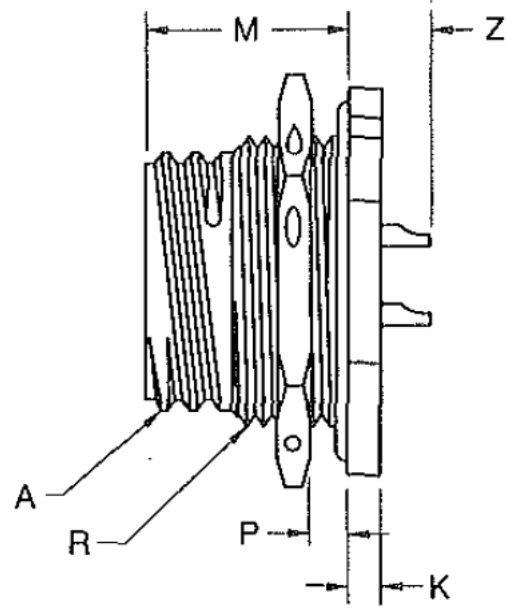
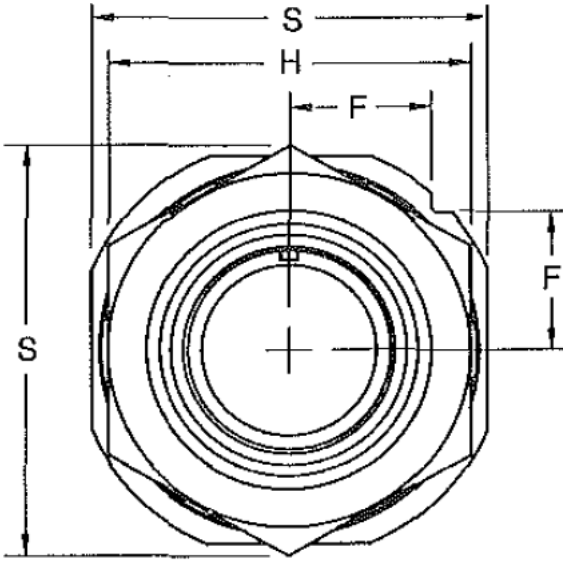

**CLASS A  
CLASS C**

For PC tail configurations, see page 15.

	RECEPTACLE FRONT VIEW			RECEPTACLE SIDE VIEW						
	F	H HEX. ±.016	S	A THREAD CLASS 2A	K +.016 -.010	M -.010	P PANEL THICKNESS		Z MAX.	R THREAD CLASS 2A
							MIN.	MAX.		
8	.594	.812	.5000 OS	.490	.875	.416	.4375-28 UNEF	.466	.297	.590
10	.719	.938	.6250 OS	.490	.875	.416	.5625-24 UNEF	.466	.421	.717
12	.612	1.031	.7500 OS	.490	.875	.416	.6875-24 UNEF	.466	.546	.834
14	.906	1.125	.8750 OS	.490	.875	.416	.8125-20 UNEF	.466	.663	.970
16	.969	1.219	1.0000 OS	.490	.875	.416	.9375-20 UNEF	.466	.787	1.088
18	1.062	1.312	1.1250 OS	.490	.875	.416	1.0625-18 UNEF	.466	.879	1.216
20	1.156	1.438	1.2500 OS	.584	1.031	.479	1.1875-18 UNEF	.527	1.014	1.332
22	1.250	1.562	1.3750 OS	.584	1.031	.479	1.3125-18 UNEF	.527	1.135	1.460



# Series PWC07E/P/F or B Jam Nut Receptacle

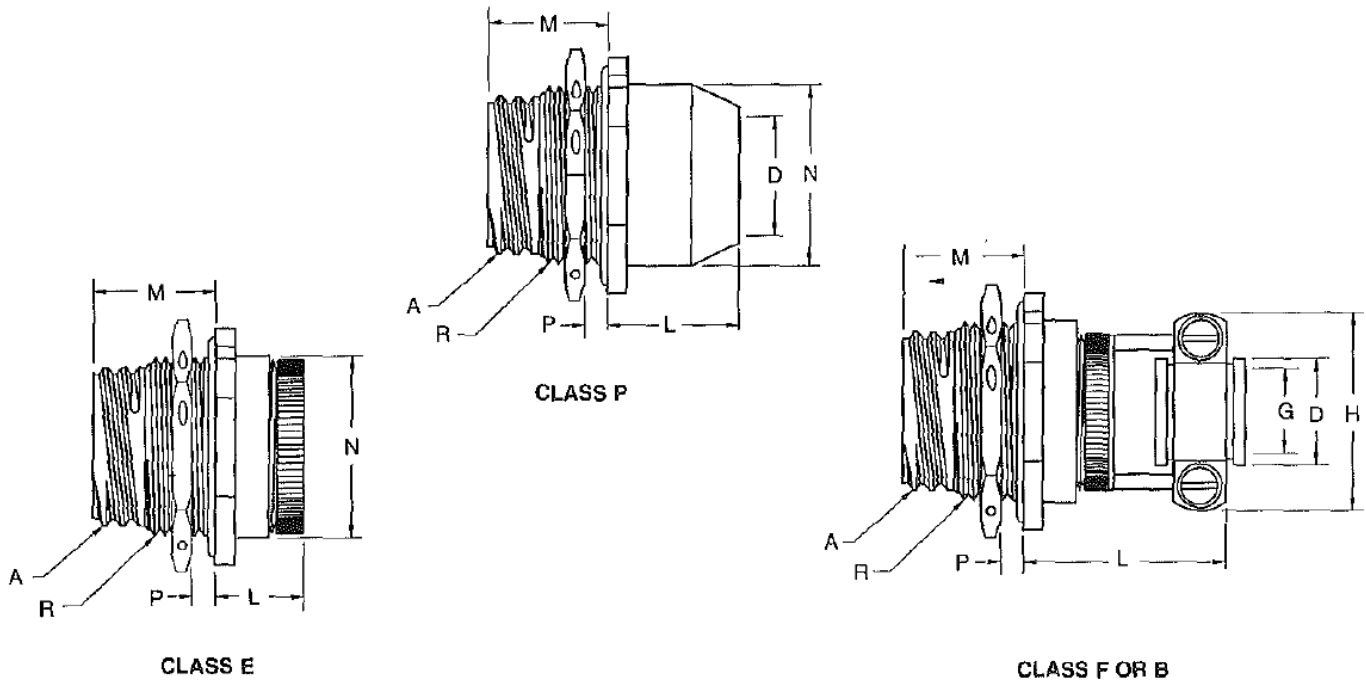

Note: front view dimension see PWC07A/C

## Common Dimension

SHELL SIZE	A THREAD CLASS 2A	M -.010	P PANEL THICKNESS		R THREAD CLASS 2A
			THICKNESS	MAX.	
10	.5000 OS	.671	.062	.125	.5625-24 UNEF
12	.6250 OS	.671	.062	.125	.6875-24 UNEF
14	.7500 OS	.671	.062	.125	.8750-20 UNEF
16	.8750 OS	.671	.062	.125	1.0000-20 UNEF
18	1.0000 OS	.671	.062	.125	1.1250-18 UNEF
20	1.1250 OS	.671	.062	.125	1.2500-18 UNEF
22	1.2500 OS	.797	.062	.250	1.3750-18 UNEF
22	1.3750 OS	.797	.062	.250	1.5000-18 UNEF

SHELL SIZE	CLASS E			CLASS F (SR), B (SR)					CLASS P	
	N MAX.	L MAX.	C THREAD	p MIN.	G DIA.	H MAX.	L MAX.	D MIN.	L MAX.	N MAX.
8	6-32	.240	.125	.812	1.740	.550	1.250	.560	.317	1.406
10	6-32	.302	.188	.875	1.740	.675	1.250	.685	.434	1.406
12	6-32	.428	.312	1.000	1.740	.803	1.250	.813	.548	1.406
14	6-32	.552	.375	1.125	1.740	.920	1.250	.930	.673	1.406
16	6-32	.615	.500	1.188	1.882	1.047	1.250	1.057	.978	1.406
18	8-32	.740	.625	1.438	1.872	1.165	1.250	1.175	.899	1.406
20	8-32	.740	.625	1.438	2.061	1.290	1.434	1.301	1.024	1.562
22	8-32	.928	.750	1.719	2.061	1.418	1.434	1.430	1.149	1.562



# Dust Cap

## Receptacle Protection Cap PWCOODC

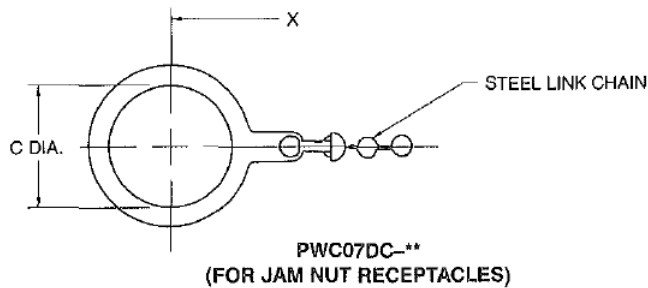
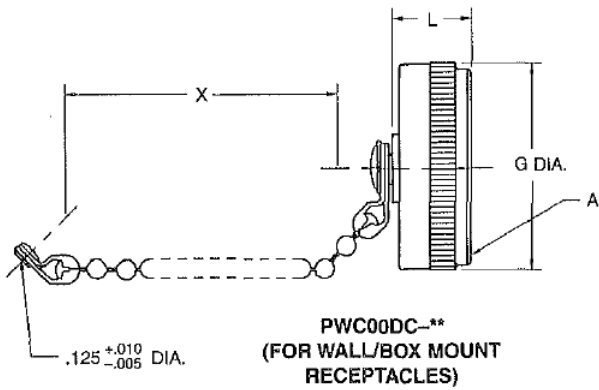

SHELL SIZE	A THREAD CLASS 2B	B $\frac{+.010}{-.000}$	G MAX.	L MIN.	X $\pm .250$
8	.5000 OS	.454	.526	.557	3.000
10	.6250 OS	.578	.643	.557	3.000
12	.7500 OS	.703	.770	.557	3.500
14	.8750 OS	.844	.897	.557	3.500
16	1.0000 OS	.969	1.025	.557	3.500
18	1.1250 OS	1.094	1.152	.557	3.500
20	1.2500 OS	1.219	1.279	.557	4.000
22	1.3750 OS	1.343	1.416	.557	4.000

\*\*Add shell size to complete order number.

## Plug Protection Cap PWC06DC

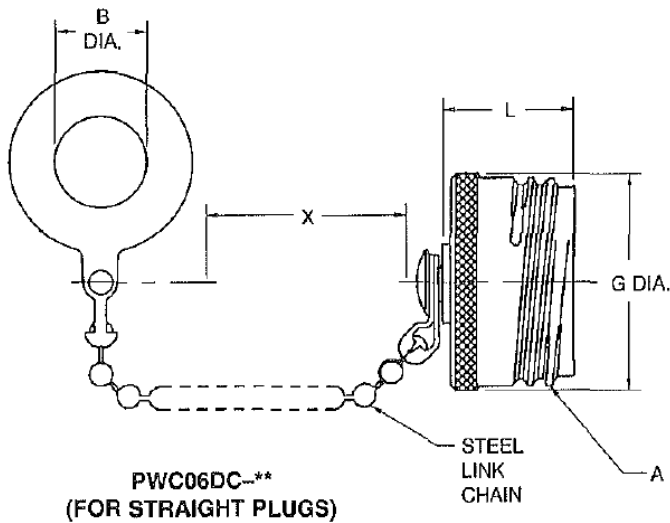

SHELL SIZE	A THREAD CLASS 2B	C $\frac{+.010}{-.000}$	G MAX.	L MIN.	X $\pm .250$
8	.5000 OS	.578	.648	.448	3.000
10	.6250 DS	.703	.776	.448	3.000
12	.7500 DS	.891	.902	.448	3.500
14	.8750 OS	1.016	1.030	.448	3.500
16	1.0000 OS	1.141	1.157	.448	3.500
18	1.1250 OS	1.266	1.284	.448	3.500
20	1.2500 OS	1.391	1.412	.448	4.000
22	1.3750 OS	1.516	1.507	.448	4.000

\*\*Add shell size to complete order number.

# Other Quality Connectors



QPL'd MIL-C-5015 &  
Special Connectors  
for Commercial Applications

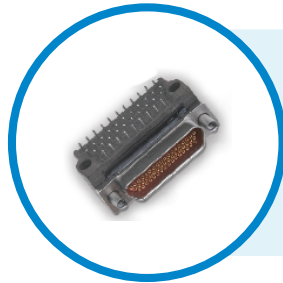

Dura-Con  
Microminiature-D Connectors



QPL'd MIL-C-26482 Series I  
Solder and Crimp Connectors



Quick Disconnect Connectors  
Solder and Crimp Types



Mini-D "MD" Connectors



Expanded Beam Fiber  
Optics



Filtered Connectors  
Solder and Crimp Connectors

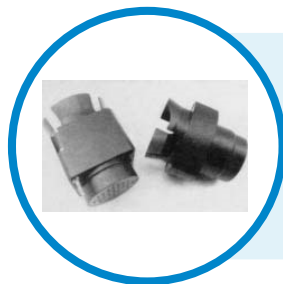

Special Cryogenic  
Connectors



Omega  
MIL-C-26500 - Cylindrical Connectors



Rugged Acme Thread  
Connectors  
for Industrial Electrical Equipment





## Proven Excellence

In operation since 1917, Cinch supplies high quality, high performance connectors and cables globally to the Aerospace, Military/Defense, Commercial Transportation, Oil & Gas, High End Computer, and other markets. We provide custom solutions with our creative, hands on engineering and end to end approach.

Our diverse product offerings include: connectors, enclosures and cable assemblies utilizing multiple contact technologies including copper and fiber optics. Our product engineering and development activities employ cutting edge technologies for design and modeling, and our various technologies and expertise enable us to deliver custom solutions and products for our strategic partnerships. We also serve a broad range of commercial markets, largely through our highly efficient distribution network.

We aim to exceed our customer's expectations, and to continually provide innovative solutions to the rapidly changing needs of the markets, and customers, we serve.

### Cinch Connectivity Solutions

Cinch Connectivity Solutions  
12400-8 S.W. 134th Court  
Miami, Florida 33186 USA  
+1 305.234 1000  
inquiry@cinch.com  
[cinch.com](http://cinch.com)

