

0RQB-D0W15L

Isolated DC-DC Converter

The 0RQB-D0W15L is an isolated DC/DC converter that provide up to 200 W of output power from a wide input range (72 V, 96 V and 110 V typical).

The unit is designed to be highly efficient. Standard features include remote on/off, input under-voltage lockout, over current protection, short circuit protection and over voltage protection. Conformal coated PCB is used for environmental ruggedness.



Key Features & Benefits

- 72/96/110 VDC Input
- 15 VDC @ 13.3 A Output
- 1/4th Brick Converter
- Isolated
- Fixed Frequency
- High Efficiency
- Input Under Voltage Lockout
- Input Over Voltage Lockout
- OCP/SCP
- Output Over-Voltage Protection
- Over Temperature Protection
- Approved to IEC/EN 62368-1 (TBC)
- Class II, Category 2, Isolated DC/DC Converter (refer to IPC-9592B)

Applications

- Industrial
- Railways
- Telecommunications

1. MODEL SELECTION

MODEL NUMBER	OUTPUT VOLTAGE	INPUT VOLTAGE	MAX. OUTPUT CURRENT	MAX. OUTPUT POWER	TYPICAL EFFICIENCY
ORQB-D0W15L	15 VDC	72/96/110 VDC	13.3 A	200 W	92%

NOTE: Add "G" suffix at the end of the model number to indicate Tray Packaging.

PART NUMBER EXPLANATION

0	R	QB	-	D0	W	15	L	G
Mounting Type	RoHS Status	Series Name		Output Power	Input Range	Output Voltage	Active Logic	Package Type
Through hole mount	RoHS	DOSA Quarter Brick		200 W	72/96/110 V	15 V	Active Low, with baseplate	Tray package

2. ABSOLUTE MAXIMUM RATINGS

PARAMETER	DESCRIPTION	MIN	TYP	MAX	UNITS
Continuous non-operating Input Voltage		-0.5	-	164	V
Remote On/Off		-0.3	-	18	V
Current Sink		0	-	10	mA
Isolation Voltage	Input to output	-	-	2250	V
Operating Temperature	Temperature measured at the center of the baseplate, full load	-40	-	95	°C
Storage Temperature		-55	-	125	°C
Altitude		-	-	2000	m

NOTE: Ratings used beyond the maximum ratings may cause a reliability degradation of the converter or may permanently damage the device.

3. INPUT SPECIFICATIONS

All specifications are typical at 25°C unless otherwise stated.

PARAMETER	DESCRIPTION	MIN	TYP	MAX	UNIT
Operating Input Voltage 1	Fully functioning for long term operation.	50	-	137.5	V
Operating Input Voltage 2	Fully functioning for 100 ms operation.	43	-	50	V
	Full function is not guaranteed but undamaged for 1s operation.	137.5	-	156	V
Input Current (full load)		-	-	5.7	A
Input Current (no load)		-	50	100	mA
Remoted Off Input Current		-	2	5	mA
Input Reflected Ripple Current (rms)		-	20	-	mA
Input Reflected Ripple Current (pk-pk)		-	50	-	mA
Under-Voltage Turn on Threshold	Turn on Threshold	46	47	49	V
Under-Voltage Turn off Threshold	Turn off Threshold, non-latching	40	41	42.5	V
Over-Voltage Shutdown Threshold	Auto-recovery and non-latching.	161	163	165	V
Over-Voltage Recovery Threshold		154	155	156	V

4. OUTPUT SPECIFICATIONS

All specifications are typical at nominal input, full load at 25°C unless otherwise stated.

PARAMETER	DESCRIPTION	MIN	TYP	MAX	UNIT
Output Voltage Set Point	Test condition of the output setpoint: Vin = 110 V, Io = 100% load at 25°C ambient.	14.7	15	15.3	V
Load Regulation		-	-	±30	mV
Line Regulation		-	-	±30	mV
Regulation Over Temperature		-	±60	±200	mV
Ripple and Noise (pk-pk)	40 kHz – 100 MHz BW, with 1µF ceramic capacitor and 220 µF bulk electrolytic at output.	-	-	250	mV
Ripple and Noise (rms)		-	-	50	mV
Output Current Range		0	-	13.3	A
Output DC Current Limit	Enter a hiccup mode, non-latching.	14	16	17	A
Rise Time	Vin = 110 V, Io = 13.3 A, with 1µF ceramic capacitor and 220 µF bulk electrolytic at output.	-	-	200	ms
Start-Up Time		-	300	500	ms
Overshoot at Turn on		-	0	3	%
Undershoot at Turn off		-	0	3	%
Output Capacitance		220	-	5000	µF
Transient Response					
50% load to 75% Load		-	-	600	mV
Settling Time	di/dt = 0.1 A/µs, with 1 µF ceramic capacitor and 220 µF bulk electrolytic at output.	-	-	2	ms
75% load to 50% Load		-	-	600	mV
Settling Time		-	-	2	ms

5. GENERAL SPECIFICATIONS

PARAMETER	DESCRIPTION	MIN	TYP	MAX	UNIT
Efficiency	Io=60% Irate – 100% Irate	91	92	-	%
	Io=40% Irate - 60% Irate	89	91	-	%
Switching Frequency		-	250	-	kHz
Output Voltage Trim Range		13.5	-	16.5	V
Over Temperature Protection	Temperature measured at the center of the baseplate, full load	-	110	-	°C
Output Over Voltage Protection	Enter a latching, non-hiccup mode	-	-	17.5	V
Weight		-	69	-	g
FIT	Calculated Per Bell Core SR-332 (Vin = 110 V, Vo = 15 V, Io = 10.67 A, Ta = 25°C, FIT=10 ⁹ /MTBF)	-	190.48	-	-
MTBF		-	5.25	-	Mhrs
Dimensions (L × W × H)			2.45 x 1.45 x 0.59		inch
			62.23 x 36.83 x 15		mm
Isolation Characteristics					
Input to Output		-	-	2250	VDC
Input to Heatsink		-	-	2250	VDC
Output to Heatsink		-	-	2250	VDC
Isolation Resistance		10M	-	-	Ohm
Isolation Capacitance		-	2200	-	pF



Asia-Pacific
+86 755 298 85888

Europe, Middle East
+353 61 225 977

North America
+1 408 785 5200

6. EFFICIENCY DATA

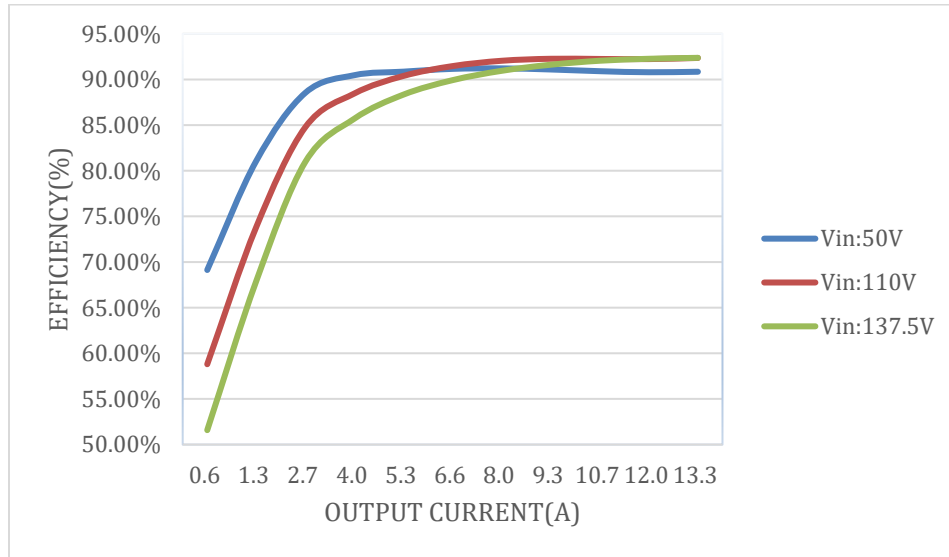

Figure 1. Efficiency data

7. REMOTE ON/OFF

PARAMETER	DESCRIPTION	MIN	TYP	MAX	UNIT
Signal Low (Unit On)	Active Low	-0.3	-	0.8	V
Signal High (Unit Off)	Remote On/Off pin is open, the module is off	2.4	-	18	V
Current Sink		0	-	1	mA

Recommended remote on/off circuit for active low

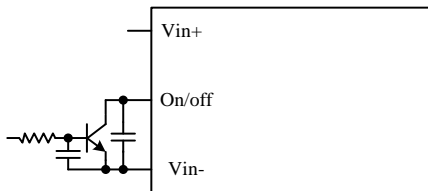

Figure 2. Control with open collector/drain circuit

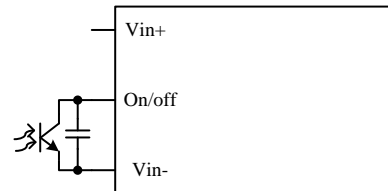

Figure 3. Control with photocoupler circuit

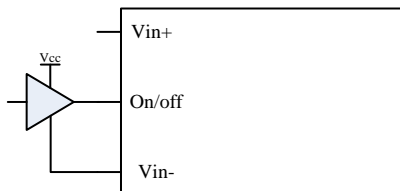

Figure 4. Control with logic circuit

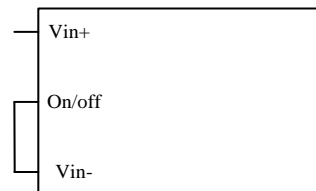

Figure 5. Permanently on

8. REMOTE SENSE

This module has remote sense compensation feature. It can minimize the effects of resistance between output and load in system layout and facilitates accurate voltage regulation at load terminals or other selected point.

1. The remote sense lines carries very little current and hence do not require a large cross-sectional area.
2. This module compensates for a maximum drop of 4% of the nominal output voltage.
3. If the unit is already trimmed up, the available remote sense compensation range should be correspondingly reduced. The total voltage increased by trim and remote sense should not exceed 4% of the nominal output voltage.
4. When using remote sense compensation, all the resistance, parasitic inductance and capacitance of the system are incorporated within the feedback loop of this module which can make an effect on the module's compensation, affecting the stability and dynamic response. A 0.1 μ F ceramic capacitor can be connected at the point of load to de-couple noise on the sense wires.
5. Recommend the connection of remote sense compensation as below figure. There are a resistor RS+ (100 ohm) from Vo+ to Sense+ and a resistor RS- (100 ohm) from Vo- to Sense- inside of this module.

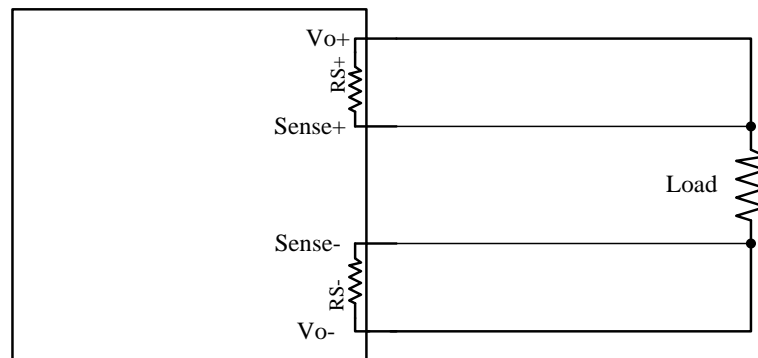

Figure 6.

6. If not using remote sense compensation, please connect sense directly to output at module's pin, that is, connect sense+ to Vo+ and sense- to Vo- at module's pin, the shorter the better. See below figure.

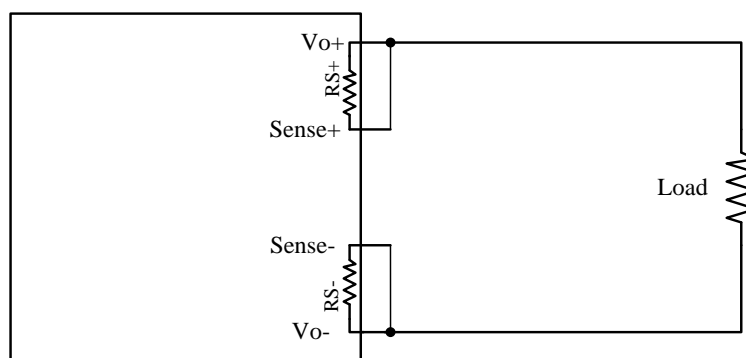

Figure 7.

9. RIPPLE AND NOISE WAVEFORM

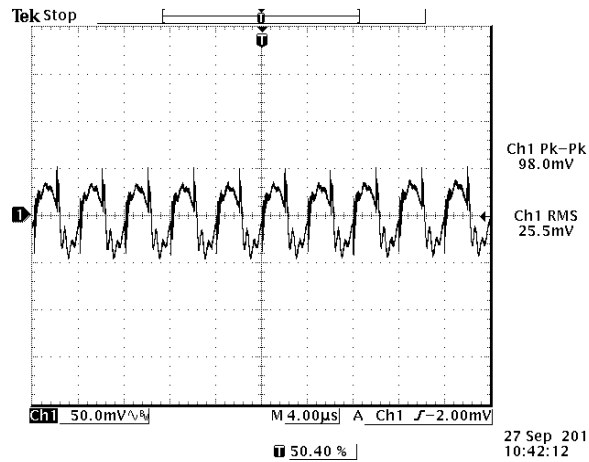

Figure 8. Ripple and noise waveform

NOTE: Ripple and noise 96 VDC input, 15 VDC /13.3 A output at $T_a = 25^\circ\text{C}$ with a $1\ \mu\text{F}$ ceramic cap and $220\ \mu\text{F}$ electrolytic cap at output.

10. TRANSIENT RESPONSE WAVEFORM

Transient Response: $di/dt = 0.1\ \text{A}/\mu\text{s}$, $1\ \mu\text{F}$ ceramic cap and $220\ \mu\text{F}$ electrolytic cap at output.

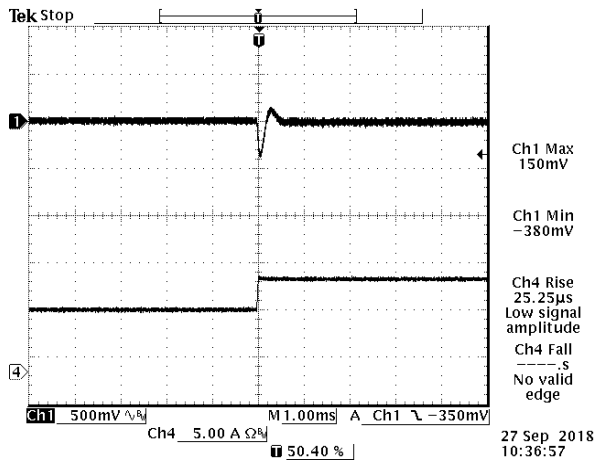

Figure 9.
CH1: V_{out}
CH2: I_{out}

$V_{out} = 15\text{V}$ 50%-75% Load Transients at $V_{in} = 96\text{V}$, $T_a = 25^\circ\text{C}$

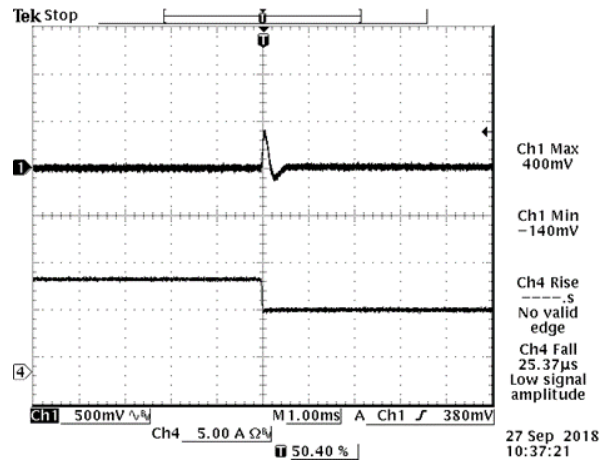

Figure 10.
CH1: V_{out}
CH2: I_{out}

$V_{out} = 15\text{V}$ 75%-50% Load Transients at $V_{in} = 96\text{V}$, $T_a = 25^\circ\text{C}$

NOTE: Transient Response at $V_{in} = 96\text{V}$, $di/dt = 0.1\text{A}/\mu\text{s}$, $1\ \mu\text{F}$ ceramic cap and $220\ \mu\text{F}$ AL. cap at output, $T_a = 25^\circ\text{C}$

11. STARTUP & SHUTDOWN

Rise time

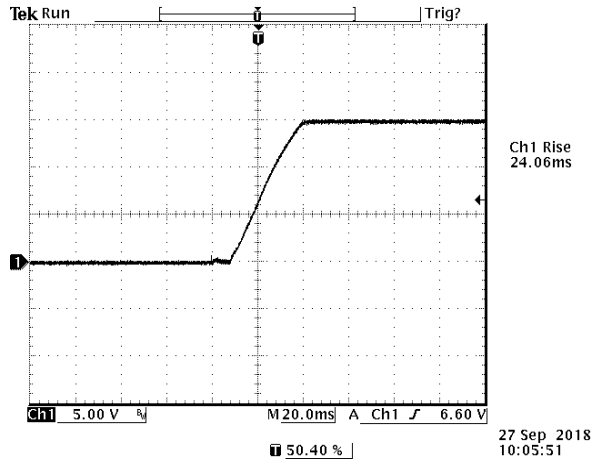

Figure 11. $V_{out} = 15\text{ V} / 13.3\text{ A}$ @ $V_{in} = 96\text{ V}$, $T_a = 25^\circ\text{C}$

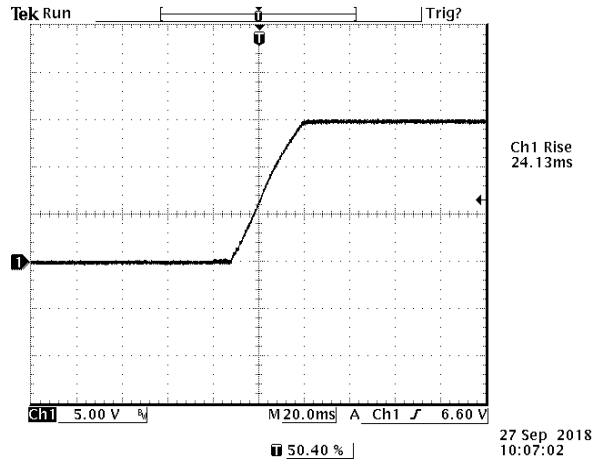

Figure 12. $V_{out} = 15\text{ V} / 13.3\text{ A}$ @ $V_{in} = 96\text{ V}$, $T_a = 25^\circ\text{C}$, $C_{ext} = 5000\text{ }\mu\text{F}$

Startup time

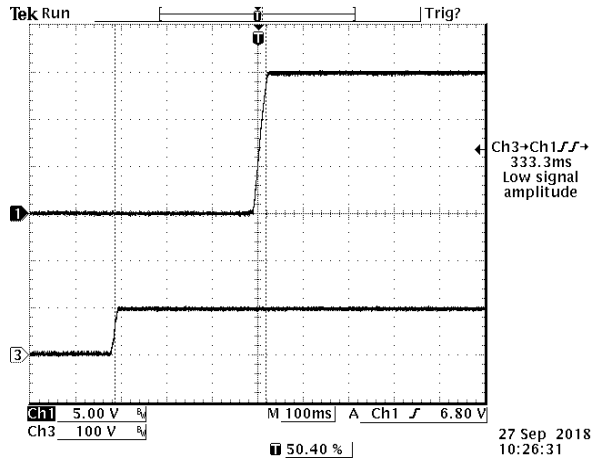

Figure 13. Startup from V_{in}
Ch1: V_o
Ch3: V_{in}
 $V_{out} = 15\text{ V} / 13.3\text{ A}$ @ $V_{in} = 96\text{ V}$, $T_a = 25^\circ\text{C}$

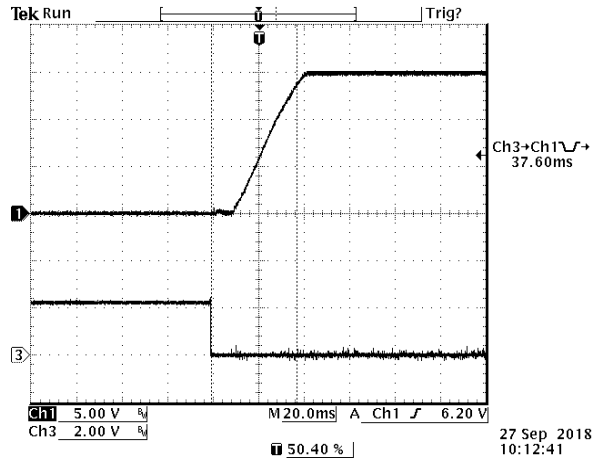

Figure 14. Startup from ON/OFF
Ch1: V_o
Ch3: ON/OFF
 $V_{out} = 15\text{ V} / 13.3\text{ A}$ @ $V_{in} = 96\text{ V}$, $T_a = 25^\circ\text{C}$

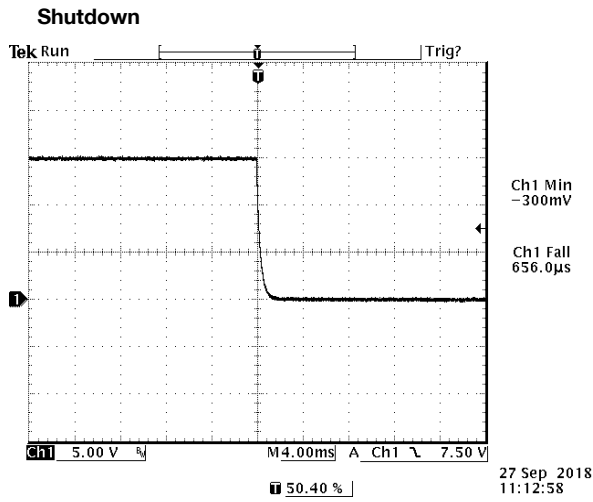

Figure 15. $V_{out} = 15\text{ V} / 13.3\text{ A} @ V_{in} = 96\text{ V}, T_a = 25^\circ\text{C}$

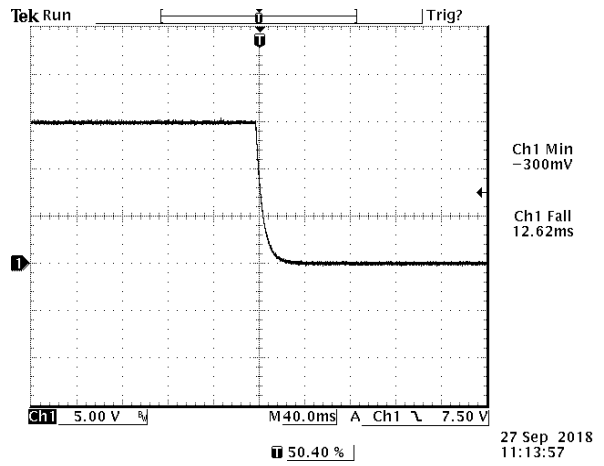

Figure 16. $V_{out} = 15\text{ V} / 13.3\text{ A} @ V_{in} = 96\text{ V}, T_a = 25^\circ\text{C}$
 $C_{ext} = 5000\text{ }\mu\text{F}$

12. OVER CURRENT PROTECTION

To provide protection in a fault output overload condition, the module is equipped with internal current-limiting circuitry and can endure current limiting for a few milli-seconds. If the overcurrent condition persists beyond a few milliseconds, the module will shut down into hiccup mode and restart once every 800 ms. The module operates normally when the output current goes into specified range. The typical average output current is 0.020 A during hiccup.

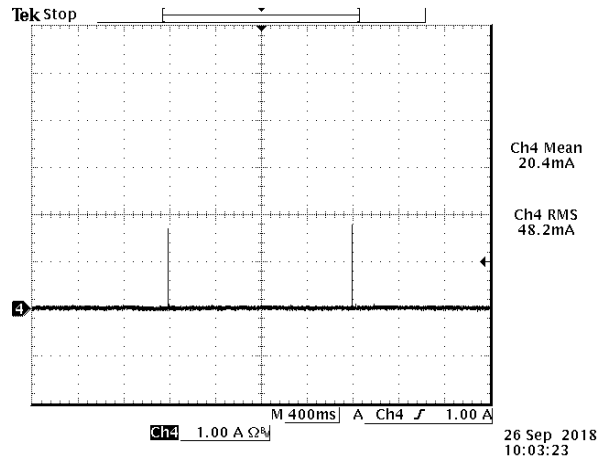

Figure 17. Over current protection

13. OVER TEMPERATURE PROTECTION

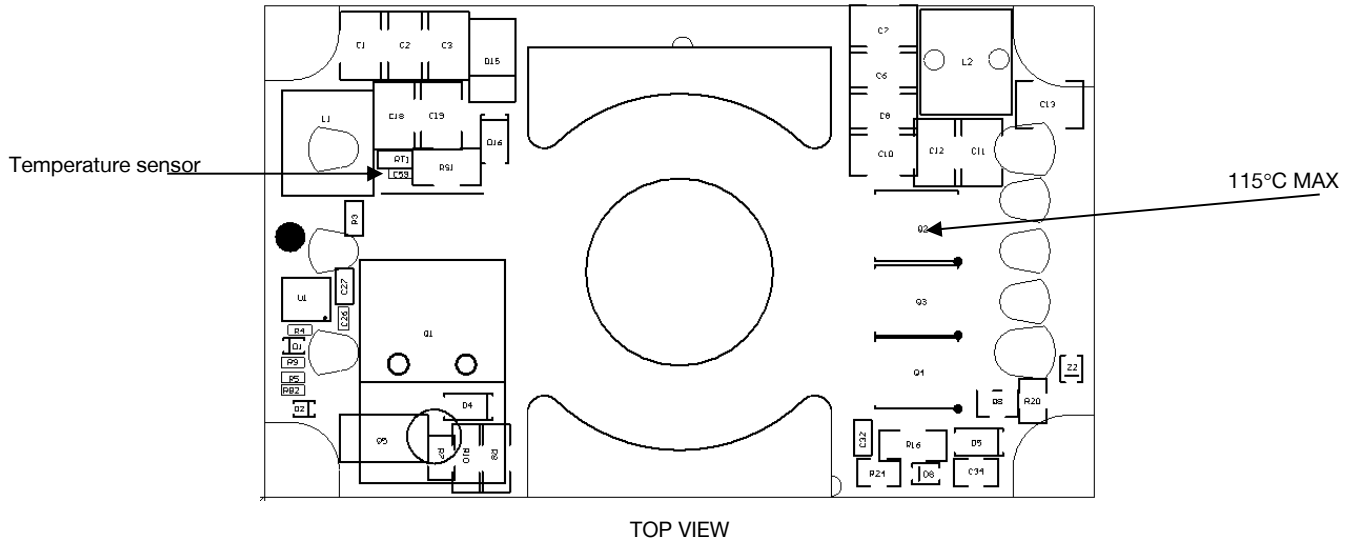

Figure 18. Over temperature protection

14. INPUT UNDER-VOLTAGE LOCKOUT

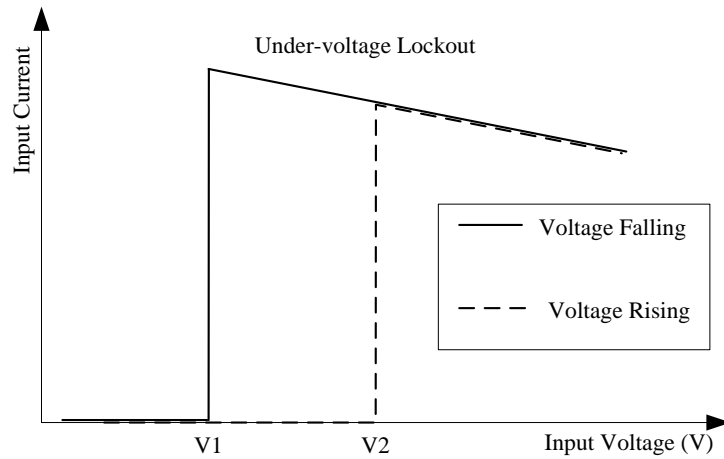

Figure 19. Input under-voltage lockout

V1 = 38 V
V2 = 40 V

15. THERMAL DERATING CURVE

1. In order to make it convenient for safety and test engineer, each curve has 3 air velocity at most. It is better that the middle one is at the centre of minimum and maximum. For example, 0-200-400, 0-100-200, 100-200-300.

2. If the minimum air velocity is 0 LFM or 50 LFM, do not mark on the curve, just record as "Natural Convection".

Maximum junction temperature of semiconductors derated to 115 °C.

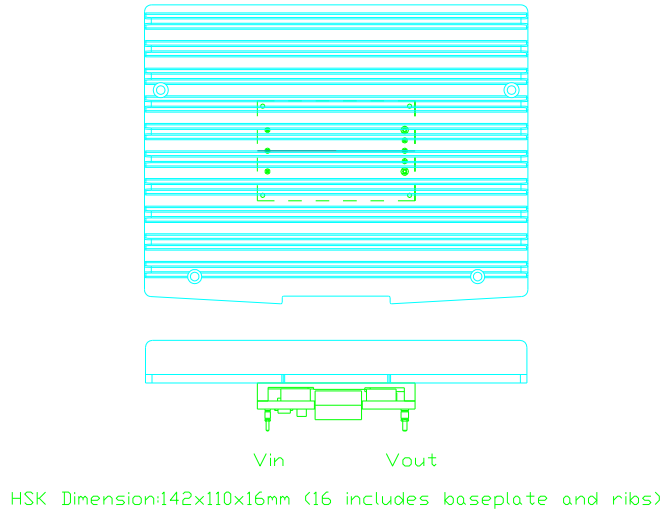

Figure 20. Thermal test setup

TA is the temperature on the large heatsink rib.

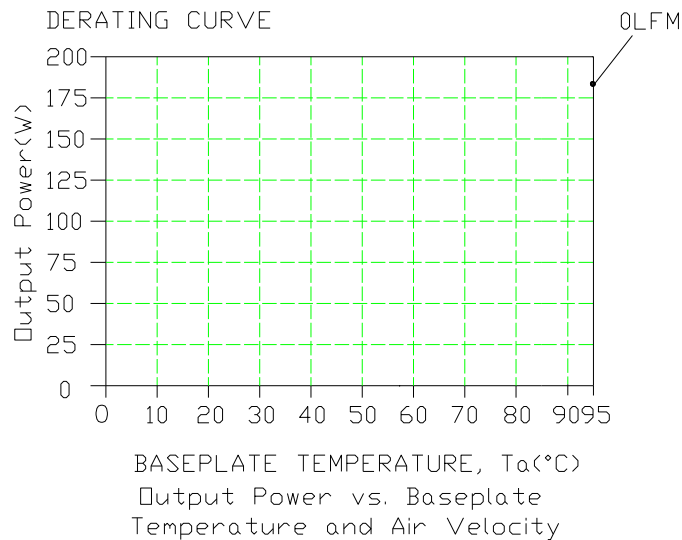

Figure 21. Thermal derating curve

16. TRIM

ORQB-D0W15L Trim Resistor Calculate

Trim down test circuit

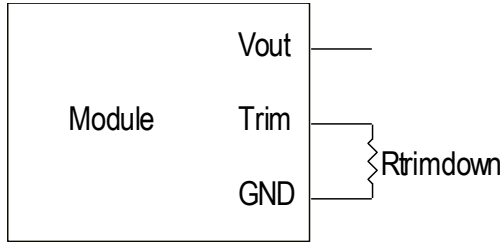

Figure 22. Trim down test circuit

$$R_{trimdown} = \frac{V_{o_req}}{15 - V_{o_req}} - 1 [K\Omega]$$

Trim up test circuit

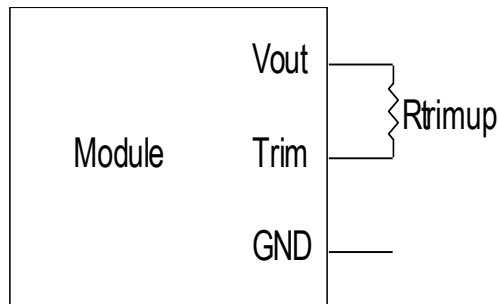

Figure 23. Trim up test circuit

$$R_{trimup} = \frac{1 - 0.08267}{0.08267 - 1.24/V_{o_req}} - 1$$

NOTE: Vo_req=Desired(trimmed) output voltage[V].

17. SAFETY & EMC

Safety:

Compliance to IEC/EN 62368-1(TBC)

EMC:

Compliance to EN55032 class A (both peak and average) with the following inductive and capacitive filter

Test Setup:

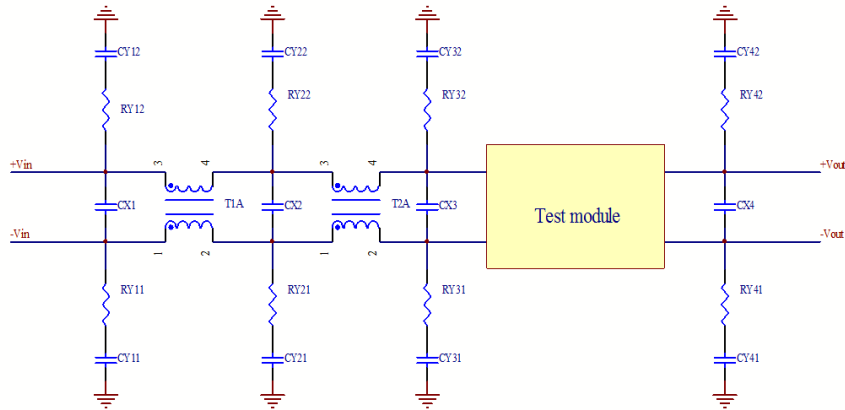

Figure 24.

T1A	CX1	RY11	RY12	CY11	CY12
1mH	0.22uF	-	-	-	-
T2A	CX2	RY21	RY22	CY21	CY22
-	0.22uF	0R	0R	2200pF	2200pF
-	CX3	RY31	RY32	CY31	CY32
-	100uF/200V AL *2	-	-	-	-
-	CX4	RY41	RY42	CY41	CY42
-	220uF AL	-	-	-	-

Positive:

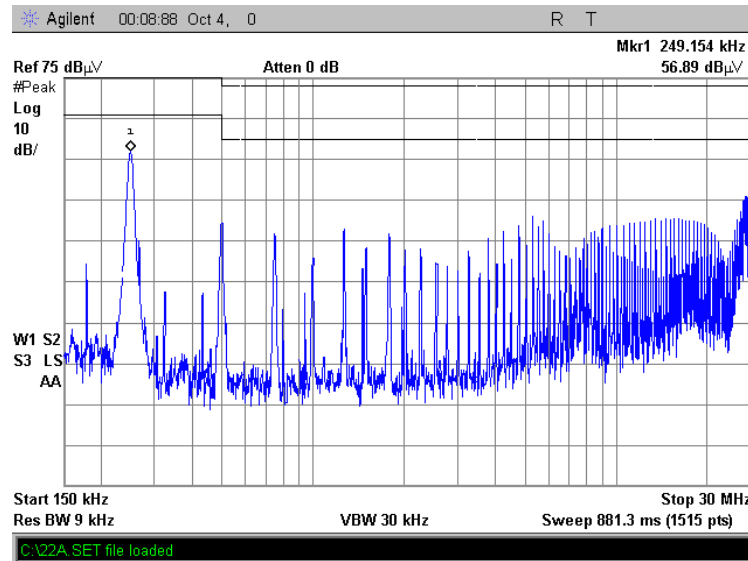

Figure 25.

Negative:

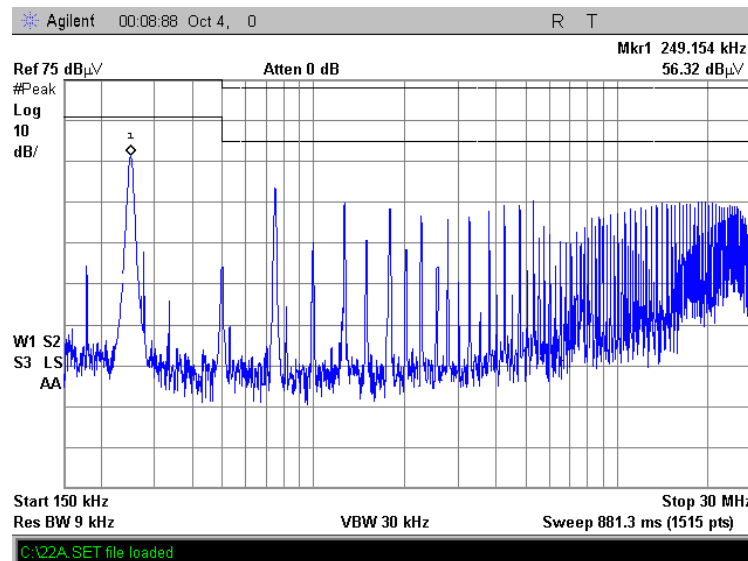

Figure 26.

18. MECHANICAL DIMENSIONS

OUTLINE

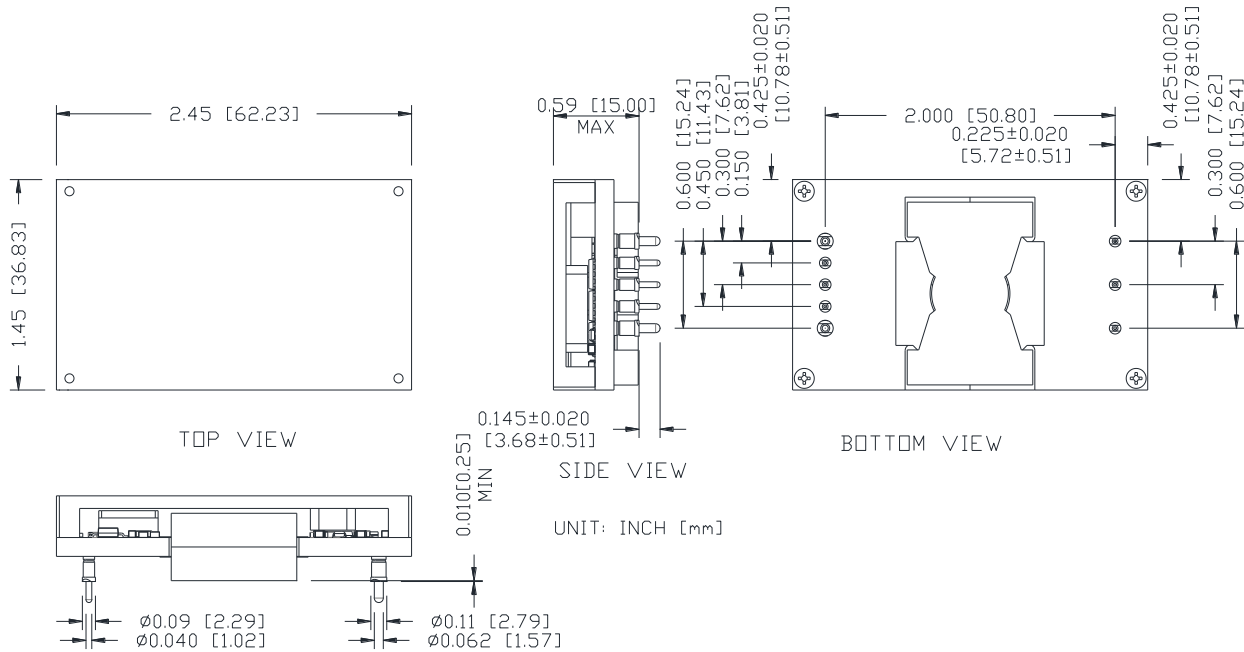

Figure 27. Outline

NOTE: This module is recommended and compatible with Pb-Free Wave Soldering and must be soldered using a peak solder temperature of no more than 260 °C for less than 5 seconds.

NOTES:

- 1) All Pins: Material - Copper Alloy;
Finish - Tin plated.
- 2) Un-dimensioned components are shown for visual reference only.
- 3) All dimensions in inches; Tolerances: x.xx +/-0.02 in [0.50 mm], x.xxx +/-0.010 in [0.25 mm].

PIN DEFINITIONS

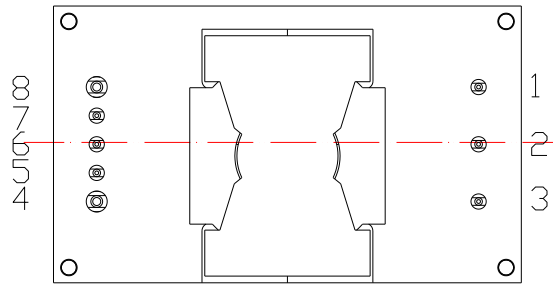

BOTTOM VIEW

Figure 28. Pins

PIN	FUNCTION	PIN	FUNCTION
1	Vin (+)	5	Sense(-)
2	On/off	6	Trim
3	Vin (-)	7	Sense(+)
4	Vout(-)	8	Vout(+)

RECOMMENDED PAD LAYOUT

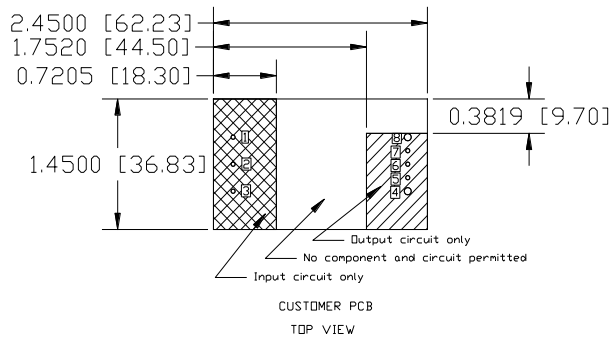
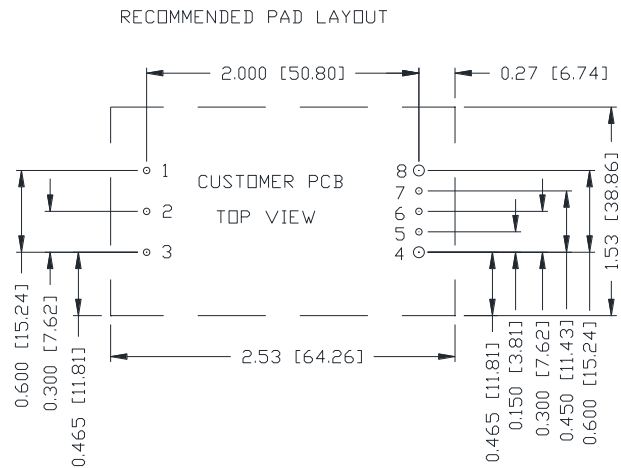

Figure 29. Recommended pad layout-1



1,2,3,5,6,7 \varnothing 0.050 HOLE SIZE, \varnothing 0.100 min PAD SIZE
 4,8 \varnothing 0.074 HOLE SIZE, \varnothing 0.120 min PAD SIZE

Figure 30. Recommended pad layout-2

19. REVISION HISTORY

DATE	REVISION	CHANGES DETAIL	APPROVAL
2018-10-09	AA	First release	S.Wang
2019-03-13	AB	Second release, Update Safety & EMC circuit parameters, no load current	S.Wang
2019-06-18	AC	Update mechanical outline. Add model photo. Add EMC waveforms.	F.Tao
2020-10-10	AD	Delete preliminary watermark.	XF.Jiang
2021-03-15	AE	Add object ID. Update recommended pad layout.	XF.Jiang

For more information on these products consult: tech.support@psbel.com

NUCLEAR AND MEDICAL APPLICATIONS - Products are not designed or intended for use as critical components in life support systems, equipment used in hazardous environments, or nuclear control systems.

TECHNICAL REVISIONS - The appearance of products, including safety agency certifications pictured on labels, may change depending on the date manufactured. Specifications are subject to change without notice.