

SRSB-80T12C

Isolated DC-DC Converter

The SRSB-80T12C is an isolated DC-DC converter that operates from a nominal 48 VDC source. This secondary side control unit will provide up to 100 W of output power from a nominal 48 VDC input.

Features include start-up into pre-biased load, remote on/off, over current protection and under voltage lockout. This converter is provided in an industry standard sixteenth brick package.

Key Features & Benefits

- 48 VDC Input
- 12 VDC / 8.3 A Output
- 1/16th Brick Converter
- Isolated
- Input Under-Voltage Lockout
- Fixed Frequency (400 kHz)
- Start-up into Pre-biased Load
- High Efficiency
- OCP/SCP
- High Power Density
- Over Temperature Protection
- Low Cost
- Remote On/Off
- Basic Insulation
- Output Over-Voltage Protection with Auto-Recovery
- Secondary Side Control for Fast Transient Response and High Reliability
- Approved to UL/CSA 62368-1
- Approved to IEC/EN 62368-1
- Class II, Category 2, Isolated DC/DC Converter (refer to IPC-9592B)



Applications

- Networking
- Computers and Peripherals
- Telecommunications



bel POWER SOLUTIONS & PROTECTION

a bel group

belfuse.com/power-solutions

1. MODEL SELECTION

MODEL NUMBER	OUTPUT VOLTAGE	INPUT VOLTAGE	MAX. OUTPUT CURRENT	MAX. OUTPUT POWER	TYPICAL EFFICIENCY
SRSB-80T12CG	12 VDC	45 – 55 VDC	8.3 A	100 W	93%
SRSB-80T12CR					

PART NUMBER EXPLANATION

S	R	SB	-	80	T	12	C	x
Mounting Type	RoHS Status	Series Name		Output Power	Input Range	Output Voltage	Active Logic	Package Type
Surface Mount	RoHS	1/16th Brick		100 W	45 – 55 V	12 V	Active Low, with HSK and Fins	G – Tray Package R – Tape and Reel Package

2. ABSOLUTE MAXIMUM RATINGS

PARAMETER	DESCRIPTION	MIN	TYP	MAX	UNITS
Continuous non-operating Input Voltage		-0.3	-	80	V
Input Transient Voltage	100 ms maximum	-	-	100	V
I/O Isolation Voltage		-	-	1500	V
Ambient Temperature		-40	-	70	°C
Storage Temperature		-55	-	125	°C
Altitude	Ta = 45°C	-	-	3000	m

NOTE: Ratings used beyond the maximum ratings may cause a reliability degradation of the converter or may permanently damage the device.

3. INPUT SPECIFICATIONS

PARAMETER	DESCRIPTION	MIN	TYP	MAX	UNIT
Operating Input Voltage		45	48	55	V
Input Current (full load)		-	-	3.5	A
Input Current (no load)		-	40	70	mA
Remote Off Input Current		-	2	5	mA
Input Reflected Ripple Current (pk-pk)	Detail conditions please refer to input reflected ripple current section.	-	-	20	mA
I ² t Inrush Current Transient		-	-	1	A ² s
Turn-on Voltage Threshold		41	-	45	V
Turn-off Voltage Threshold		39	-	43	V
Over-voltage Shutdown Threshold		61	-	64	V
Lockout Hysteresis Voltage		2	-	-	V

CAUTION: This converter is not internally fused. An input line fuse must be used in application.

Recommend a fast-acting fuse with maximum rating of 5A on system board. Refer to the fuse manufacture's datasheet for further information.

NOTE: This converter has internal L-C (0.47 µF - 0.33 µH - 2.35 µF) filter.

4. OUTPUT SPECIFICATIONS

PARAMETER	DESCRIPTION	MIN	TYP	MAX	UNIT
Output Voltage Set Point	Vin = 48 V, Io = 50% load	11.76	12.00	12.24	V
Load Regulation		-	±12	±24	mV
Line Regulation		-	±12	±24	mV
Regulation Over Temperature		-	±60	±100	mV
Output Ripple and Noise (pk-pk)	0 – 20 MHz BW, with a 1 µF ceramic and a 10 µF Tan capacitor at output.	-	100	-	mV
Output Ripple and Noise (rms)		-	30	-	mV
Output Current Range		0	-	8.3	A
Output DC Current Limit		9.2	10.4	11.6	A
Short Circuit Surge Transient		-	-	3	A ² s
Rise Time (from ON/OFF or Vin)	From 10% to 90% of Vo	-	25	28	ms
Turn on Delay Time	Enable from Vin. Delay time from Vin to 10% of Vo	-	27	32	ms
	Enable from ON/OFF. Delay time from ON/OFF to 10% of Vo	-	27	32	
Overshoot at Turn on		-	0	3	%
Output Capacitance	Typically the ceramic capacitance is lower than 600 µF	0	-	3300	µF
TRANSIENT RESPONSE					
ΔV 50% ~ 75% of Max Load		-	150	250	mV
Setting Time	di/dt = 0.1 A/µs, Vin = 48 VDC, Ta = 25°C	-	50	100	µs
ΔV 75% ~ 50% of Max Load	Load capacitor = 10 µF tantalum + 1 µF ceramic	-	150	250	mV
Setting Time		-	50	100	µs

NOTE: All specifications are typical at nominal input, full load at 25°C unless otherwise stated.



bel POWER
SOLUTIONS &
PROTECTION
a bel group

Asia-Pacific
+86 755 298 85888

Europe, Middle East
+353 61 49 8941

North America
+1 866 513 2839

5. GENERAL SPECIFICATIONS

PARAMETER	DESCRIPTION	MIN	TYP	MAX	UNIT
Efficiency		91	93	-	%
Switching Frequency		-	400	-	kHz
Over Temperature Protection		-	125	-	°C
Output Voltage Protection (Static)	This voltage is achieved by trimming up output slowly.	-	14	-	V
Weight		-	15.5	-	g
MTBF	Calculated Per Telcordia SR-332, Issue 2 ($V_{in} = 48\text{ V}$, $V_o = 12\text{ V}$, $I_o = 8.3\text{ A}$, $T_a = 25^\circ\text{C}$, 100 LFM, FIT = $10^9/\text{MTBF}$)	-	5.28	-	Mhrs
FIT		-	189	-	-
Dimensions (L x W x H)		1.30 x 0.90 x 0.453			inch
		33.02 x 22.86 x 11.50			mm
ISOLATION CHARACTERISTICS					
Input to Output		-	-	1500	V
Isolation Resistance		10M	-	-	Ohm
Isolation Capacitance		-	1000	-	pF

6. EFFICIENCY DATA

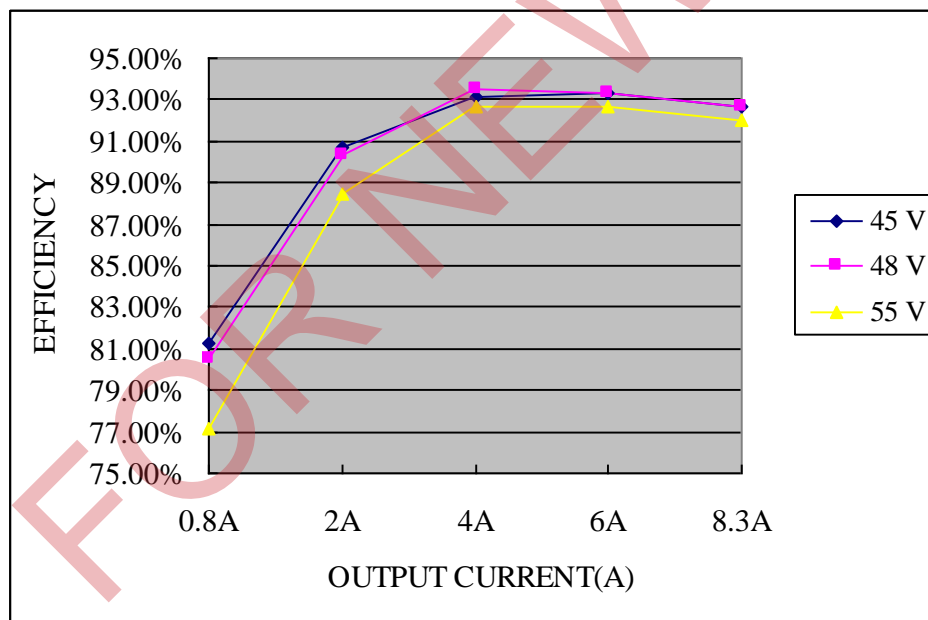

Figure 1. Efficiency data

9. REMOTE ON/OFF

PARAMETER	DESCRIPTION	MIN	TYP	MAX	UNIT
Signal Low (Unit On)	Active Low The remote on/off pin open, Unit off.	-0.3	-	0.8	V
Signal High (Unit Off)		2.4	-	18	V
Current Sink		0	-	1	mA

Recommended remote on/off circuit for active low

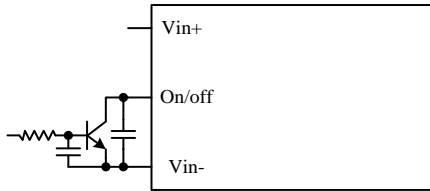

Figure 2. Control with open collector/drain circuit

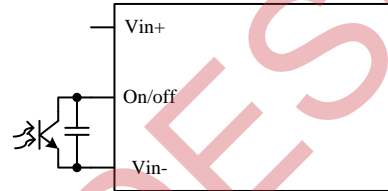

Figure 3. Control with photocoupler circuit

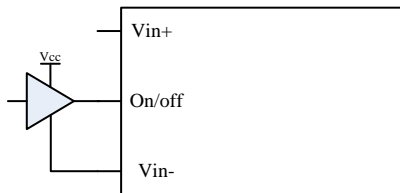

Figure 4. Control with logic circuit

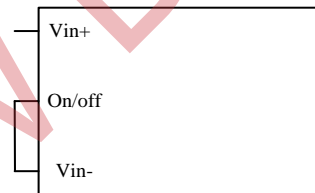

Figure 5. Permanently on

7. INPUT NOISE

Input reflected ripple current

Testing setup

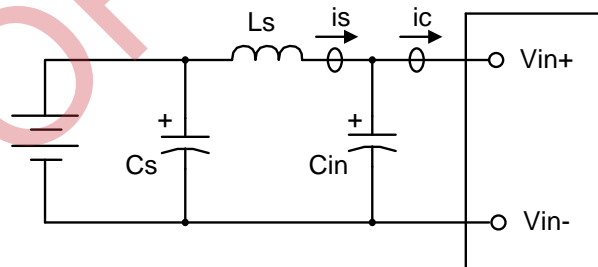

Figure 6. Test setup

Notes and values in testing:

is: Input Reflected Ripple Current

ic: Input Terminal Ripple Current

Ls: Simulated Source Impedance (12 μH)

Cs: Offset possible source Impedance (220 μF, ESR < 0.1 Ω @ 100 kHz, 20 °C)

Cin: Electrolytic capacitor, should be as close as possible to the power module to damp ic ripple current and enhance stability.
Recommendation: 100 μ F, ESR < 0.2 Ω @ 100 kHz, 20 $^{\circ}$ C.
Below measured waveforms are based on above simulated and recommended inductance and capacitance.

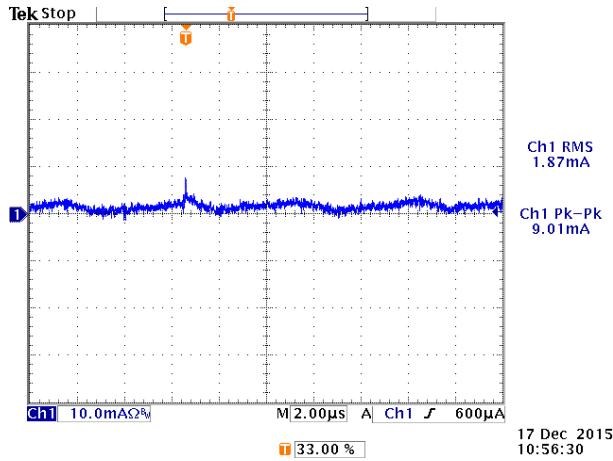

Figure 7. is (input terminal ripple current), AC component

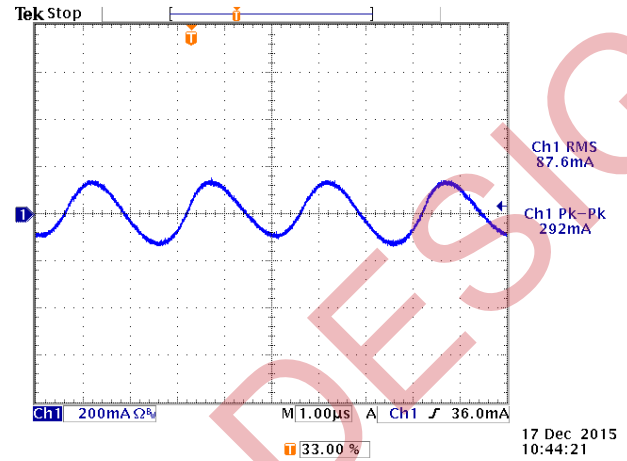

Figure 8. ic (input terminal ripple current), AC component

NOTE: Test condition: 48 VDC input, 12 VDC/8.3 A output and Ta = 25 $^{\circ}$ C, with a 1 μ F ceramic and 10 μ F Tan. Cap at output.

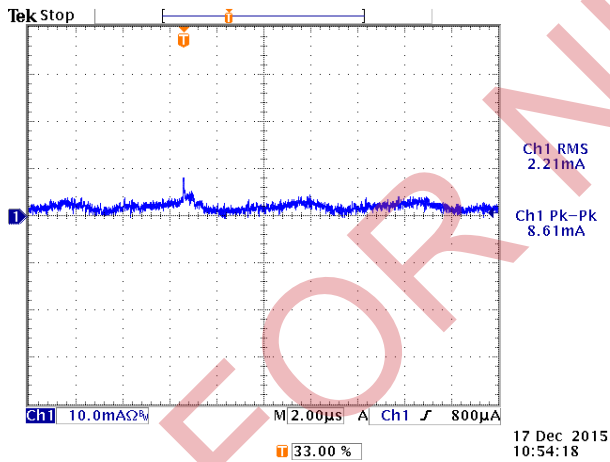

Figure 9. is (input terminal ripple current), AC component

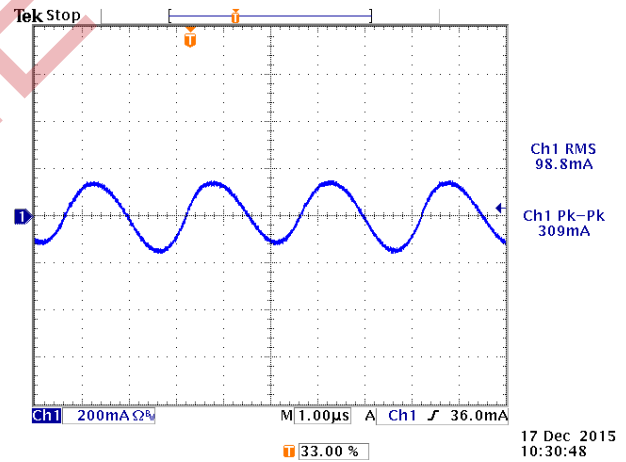

Figure 10. is (input terminal ripple current), AC component

NOTE: Test condition: 55 VDC input, 12 VDC/8.3 A output and Ta = 25 $^{\circ}$ C, with a 1 μ F ceramic and 10 μ F Tan. Cap

10. RIPPLE AND NOISE WAVEFORM

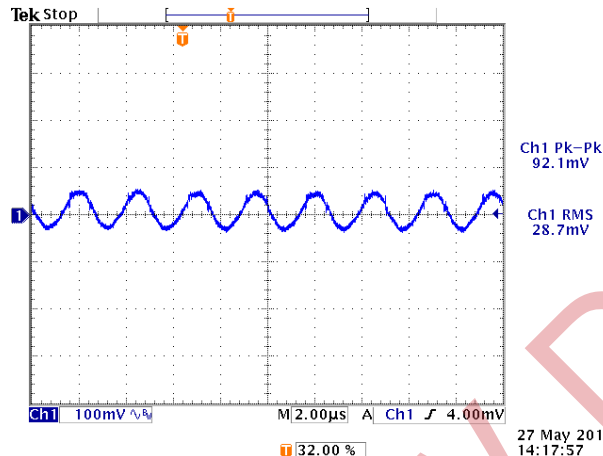

Figure 11. Ripple and noise waveform

NOTE: Ripple and noise at full load, 48 VDC input, 12 VDC/8.3 A output and $T_a = 25^\circ\text{C}$, with a 1 μF ceramic and 10 μF Tan. cap at output.

11. TRANSIENT RESPONSE WAVEFORMS

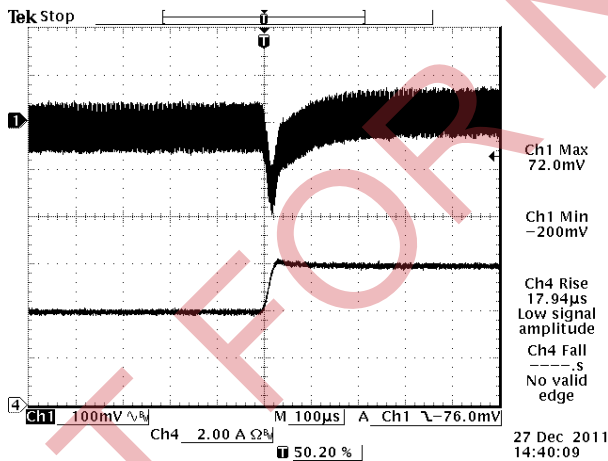

Figure 12. $V_o = 12\text{ V}$, 50% to 75% Load Transients

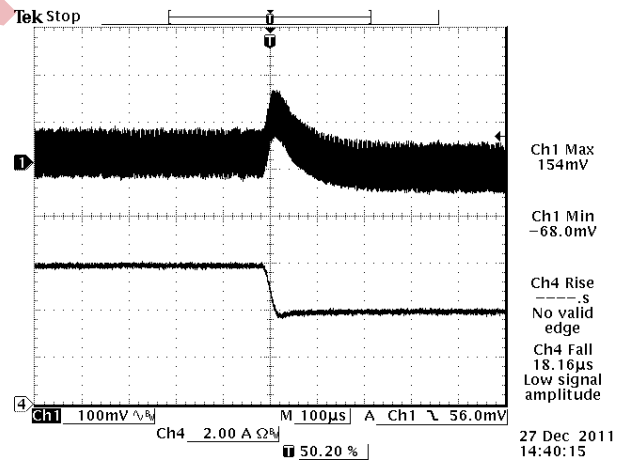

Figure 13. $V_o = 12\text{ V}$, 75% to 50% Load Transients

NOTE: Transients Response at $V_{in} = 48\text{ V}$, $di/dt = 0.1\text{ A}/\mu\text{s}$, $T_a = 25^\circ\text{C}$

12. OVER VOLTAGE PROTECTION

The output over voltage protection consists of circuitry that monitors the voltage on the output terminals. If the voltage on the output terminals exceeds the over voltage protection threshold, the module will shut down into hiccup mode and restart once every 400 ms. The module operates normally when the fault is cleared.

Test setup:

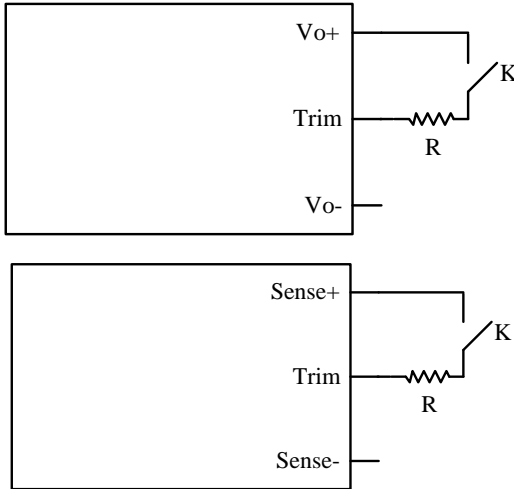

Figure 14. $R = 10\text{ k}\Omega$

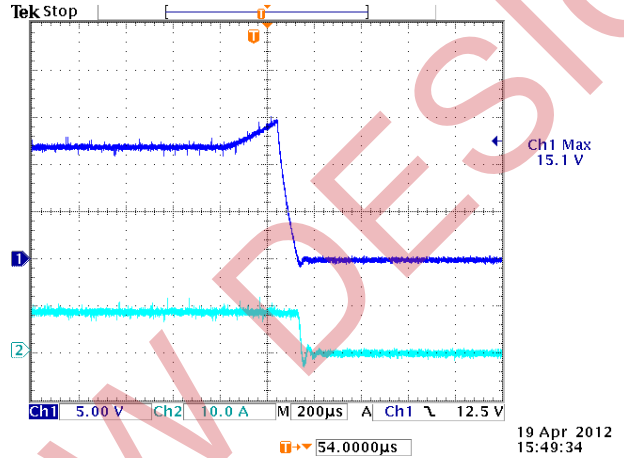

Figure 15.

CH1: Output voltage waveform

CH2: Output Current waveform

Test condition: 48 Vin, 8.3 A, Rload = 10 kΩ

19 Apr 2012
15:49:34



13. OVER TEMPERATURE PROTECTION

The OTP is achieved by thermistor R25 and the threshold is set at 125°C in non-latch mode; the hottest component Q13 reaches 130°C with 100 LFM air flow correspondingly. It will restart automatically when the temperature falls to 118°C. The protecting point will be varied a little under different conditions (air flow, ambient temperature, input voltage, load...).

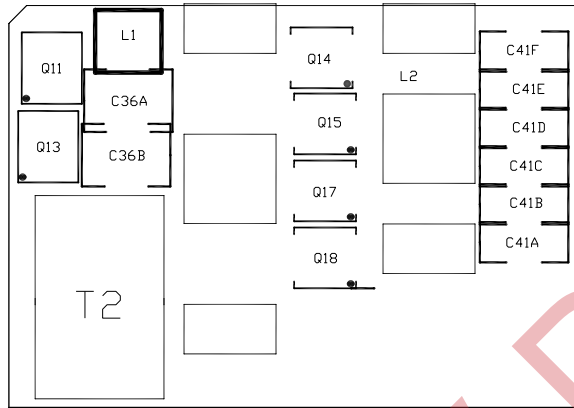

Figure 16.

14. UNDER-VOLTAGE LOCKOUT

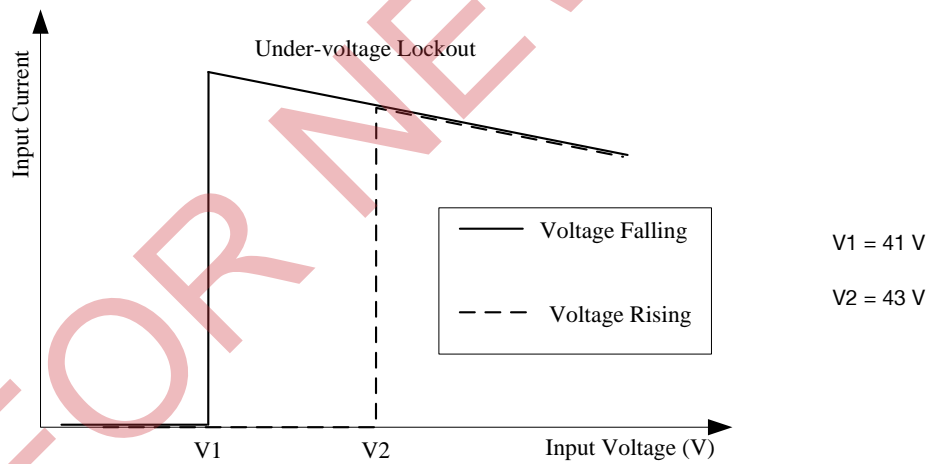

Figure 17. Input under voltage lockout

15. THERMAL DERATING CURVE

The airflow is in either the transverse or longitudinal direction.

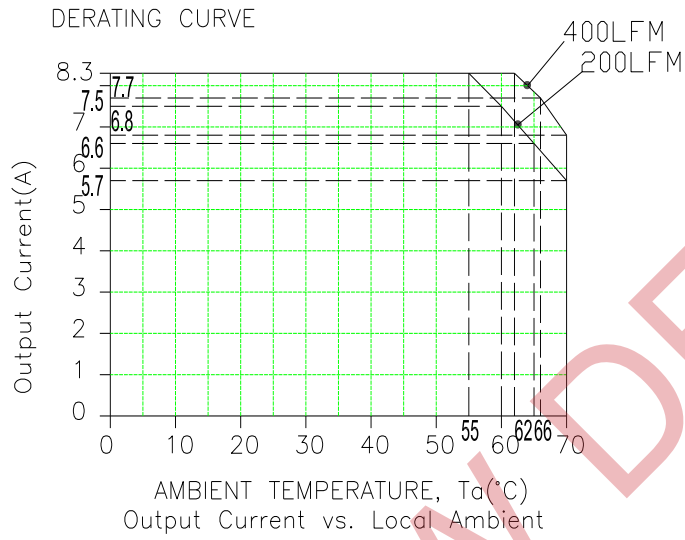

Figure 18. $V_{in} = 12V, V_{in} = 48V$

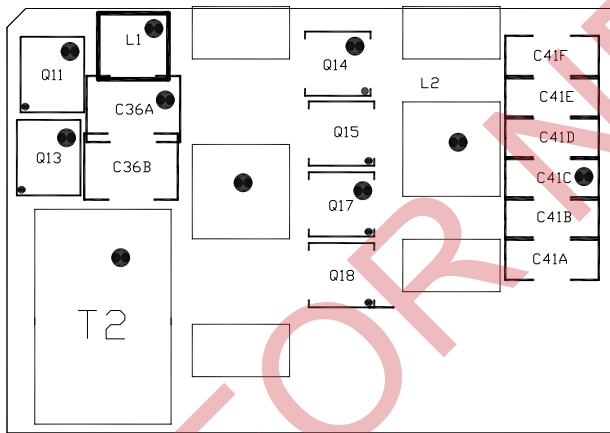

Figure 19. Temperature reference points on top side

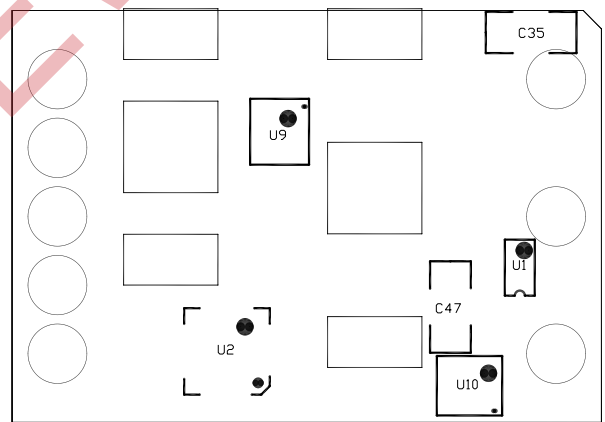

Figure 20. Temperature reference points on bottom side

16. SAFETY & EMC

Safety :

Material flammability: UL94V-0
 Approved to IEC/EN 62368-1
 Approved to UL/CSA 62368-1

EMC:

1. Surge: IEC61000-4-5
 2. DC-DIP: IEC61000-4-29
 3. Conductive EMI: EN55032 class A
- Compliance to EN55032 class A (both peak and average) with the following inductive and capacitive filter.

Setup:

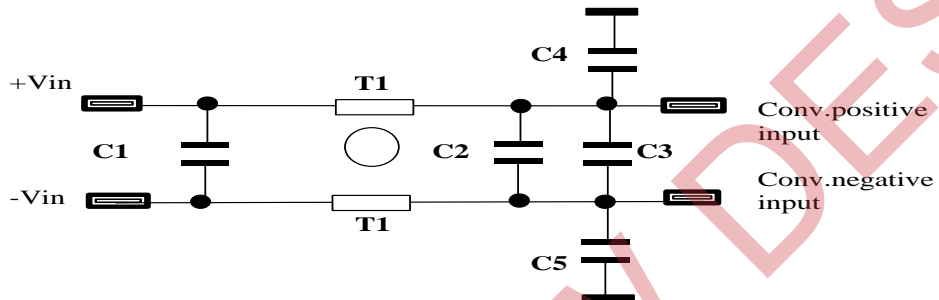

Figure 21. Test setup

ITEM	DESIGNATOR	PARAMETER	VENDOR	VENDOR P/N
1	C1	SMD-100V-2.2uF-X7R-1210	TDK	C3225X7R2A225K
2	C2			
3	C3	AL-EL CAP 220UF 20% 100V, Lead Type	Nichicon	UHE2A221MHD6
4	C4	safety capacity, 0.033uF/250V, 10.5*9*4-0.6-7.5mm, 1kV		
5	C5	SMD-2000V-3900pF-X7R-1210	Johanson	202S41W392KV4E
6	T1	Common-mode Inductor-900uH-±25%-4A-R5K-21*21*12.5mm		

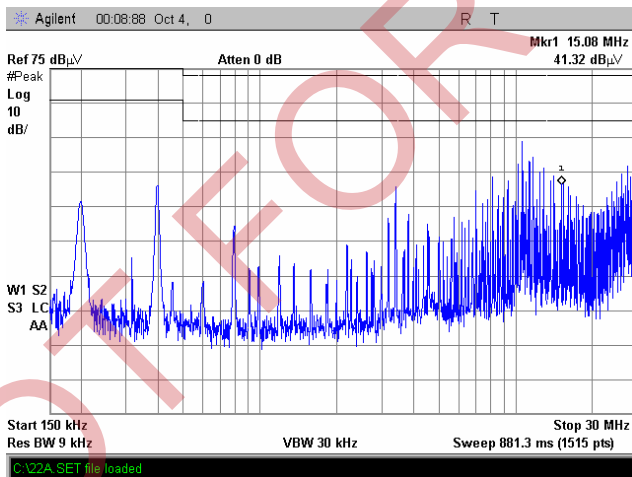

Figure 22. Positive

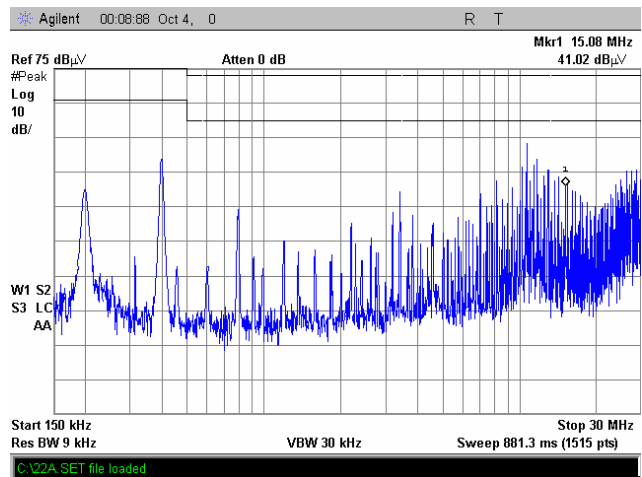

Figure 23. Negative



Asia-Pacific
 +86 755 298 85888

Europe, Middle East
 +353 61 49 8941

North America
 +1 866 513 2839

17. SOLDERING INFORMATION

The SRSB-80T12Cx modules are designed to be compatible with reflow soldering process. The suggested Pb-free solder paste is Sn/Ag/Cu(SAC). The recommended reflow profile using Sn/Ag/Cu solder is shown in the following. Recommended reflow peak temperature is 245°C while the part can withstand peak temperature of 260°C maximum for 10seconds. This profile should be used only as a guideline. Many other factors influence the success of SMT reflow soldering. Since your production environment may differ, please thoroughly review these guidelines with your process engineers.

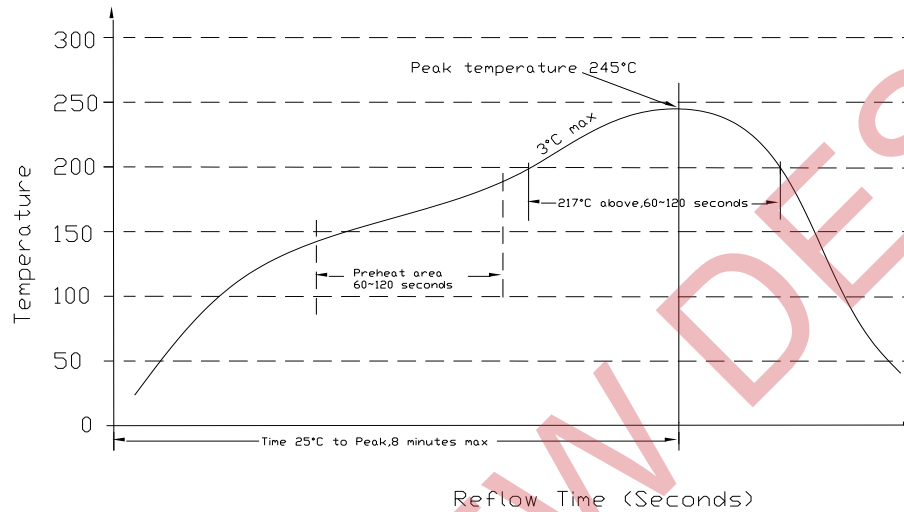

Figure 24. Soldering information

18. MSL RATING

The SRSB-80T12Cx modules have a MSL rating of 3.

19. STORAGE AND HANDLING

The SRSB-80T12Cx modules are designed to be compatible with J-STD-033 Rev:A (Handling, Packing, Shipping and Use of Moisture /Reflow Sensitive surface Mount devices). Moisture barrier bags (MBB) with desiccant are applied. The recommended storage environment and handling procedure is detailed in J-STD-03

20. PRE-BAKING

This component has been designed, handled, and packaged ready for pb-free reflow soldering. If the assembly shop follows J-STD-033 guidelines, no pre-bake of this component is required before being reflowed to a PCB. However, if the J-STD-033 guidelines are not followed by the assembler, Bel recommends that the modules should be pre-baked @ 120~125°C for a minimum of 4 hours (preferably 24 hours) before reflow soldering.

21. MECHANICAL OUTLINE
OUTLINE

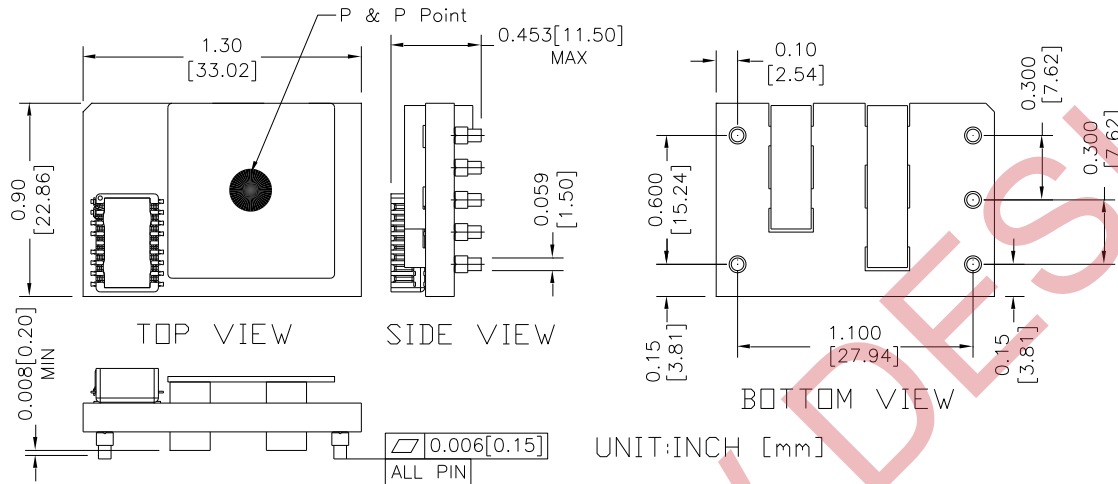

Figure 25. Outline

NOTES:

- 1) All Pins: Material - Copper Alloy;
Finish – 3 micro inches minimum Gold over 50 micro inches minimum Nickel plate
- 2) Un-dimensioned components are shown for visual reference only.
- 3) All dimensions in inch [mm]; Tolerances: x.xx +/-0.02 inch [0.51 mm]; x.xxx +/-0.010 inch [0.25 mm].



bel POWER SOLUTIONS & PROTECTION
a bel group

Asia-Pacific
+86 755 298 85888

Europe, Middle East
+353 61 49 8941

North America
+1 866 513 2839

PIN DEFINITIONS

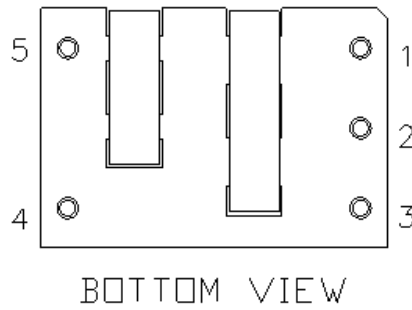
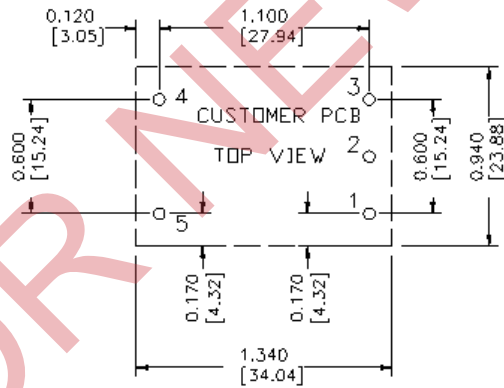

Figure 26. Pins

PIN	FUNCTION
1	Vin (+)
2	Remote On/Off
3	Vin (-)
4	Vout (-)
5	Vout (+)

RECOMMENDED PAD LAYOUT

RECOMMENDED PCB PAD LAYOUT



PAD SIZE: 1-8 ϕ 0.08[2.03]

Figure 27. Recommended pad layout



22. PACKING INFORMATION

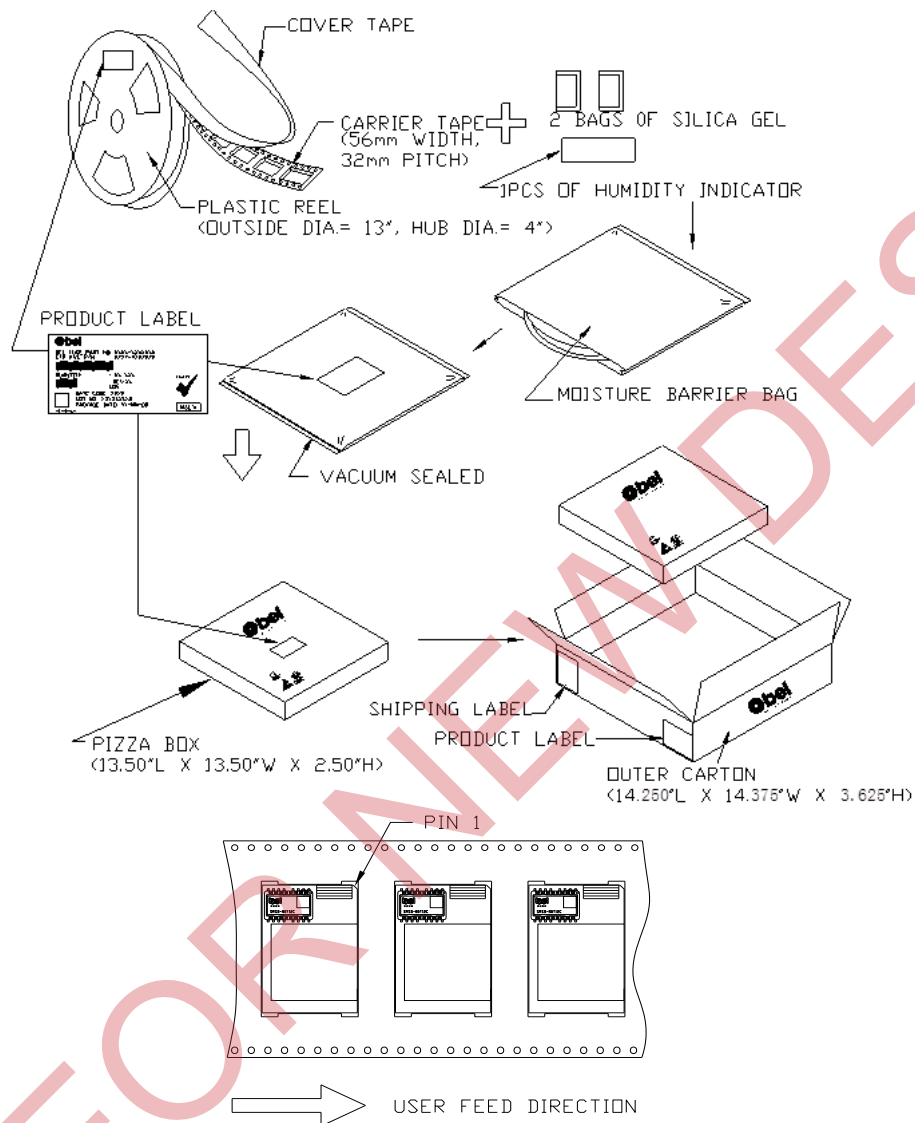

ORIENTATION OF COMPONENT INSIDE POCKET

TAPE WIDTH	56mm
POCKET PITCH	32mm
QUANTITY OF COMPONENTS PER REEL	160
PLASTIC REEL OUTER DIAMETER	13 INCHES
PLASTIC REEL HUB DIAMETER	4 INCHES
COMPLY WITH EIA 481-2-A	

Figure 28. Package information

23. REVISION HISTORY

DATE	REVISION	CHANGES DETAIL	APPROVAL
2013-06-07	A	First release	J.Yan
2014-01-18	B	Update TD curve	J.Yan
2014-09-25	C	Update Abs Max, Input specs, Output specs, General, Efficiency data, TD, NR, Start up & Shut down, OTP, UVLO	J.Yan
2015-02-13	D	Update Turn on delay time, altitude, MD	J.Yan
2015-03-11	E	Update Turn on delay time, rise time, output capacitance	J.Yan
2015-05-21	F	Add input reflected ripple current test set up, Update outline drawing.	J.Yan
2015-12-17	G	Update input reflected ripple current, add Vin OVP	J.Yan
2016-03-17	H	Add Packaging Information	J.Yan
2016-04-28	I	Update Module photo, MD, Packaging Information	J.Yan
2021-07-02	AJ	Update safety certificate and mechanical outline tolerance. Add object ID.	XF.Jiang

For more information on these products consult: tech.support@psbel.com

NUCLEAR AND MEDICAL APPLICATIONS - Products are not designed or intended for use as critical components in life support systems, equipment used in hazardous environments, or nuclear control systems.

TECHNICAL REVISIONS - The appearance of products, including safety agency certifications pictured on labels, may change depending on the date manufactured. Specifications are subject to change without notice.



tech.support@psbel.com
belfuse.com/power-solutions