

0RQB-C5U54H

Isolated DC-DC Converter

The 0RQB-C5U54H is an isolated DC/DC converter that operates from a nominal 24 / 48 VDC source.

This unit will provide up to 162 W of output power from a nominal 24 / 48 VDC input. This unit is designed to be highly efficient.

Features include over current protection, over voltage protection and input under-voltage lockout. Conformal coated PCB is used for environmental ruggedness.



Key Features & Benefits

- 24 / 48 VDC Input
- 54 VDC @ 3 A Output
- 1/4th Brick Converter
- Fixed Frequency
- High Efficiency
- Output Over-Voltage Protection
- Over Temperature Protection
- Input Under-Voltage Lockout
- Input Over-Voltage Lockout
- Conformal Coated
- Over Current and Short Circuit Protection
- Approved to UL/CSA 62368-1
- Approved to IEC/EN 62368-1
- Class II, Category 2, Isolated DC/DC Converter (refer to IPC-9592B)

Applications

- Networking
- Railways
- Computers and Peripherals
- Telecommunications



bel POWER
SOLUTIONS &
PROTECTION

a bel group

belfuse.com/power-solutions

1. MODEL SELECTION

MODEL NUMBER	OUTPUT VOLTAGE	INPUT VOLTAGE	MAX. OUTPUT CURRENT	MAX. OUTPUT POWER	TYPICAL EFFICIENCY
0RQB-C5U54HG	54 VDC	24 / 48 VDC	3 A	162 W	90%

PART NUMBER EXPLANATION

0	R	QB	-	C5	U	54	H	G
Mounting Type	RoHS Status	Series Name		Output Power	Input Range	Output Voltage	Active Logic	Package Type
Through Hole Mount	RoHS	1/4th Brick		162 W	24 / 48 V	54 V	Active Low, With Baseplate.	Tray Package

2. ABSOLUTE MAXIMUM RATINGS

PARAMETER	DESCRIPTION	MIN	TYP	MAX	UNITS
Continuous Non-operating Input Voltage		-0.5	-	80	V
Remote On/Off		-0.3	-	15	V
Trim		0	-	5	V
Current Sink		0	-	10	mA
Isolation Voltage	Input to output	-	-	2250	VDC
Operating Temperature	Temperature measured at the center of the baseplate, full load	-40	-	90	°C
	Temperature measured at the center of the baseplate, half load	-40	-	95	°C
Thermal Resistance	Baseplate to heatsink, flat greased surface	-	0.24	-	°C /W
Storage Temperature		-55	-	125	°C
Altitude		-	-	2000	m

NOTE: Ratings used beyond the maximum ratings may cause a reliability degradation of the converter or may permanently damage the device.

3. INPUT SPECIFICATIONS

All specifications are typical at 25°C unless otherwise stated.

PARAMETER	DESCRIPTION	MIN	TYP	MAX	UNIT
Operating Input Voltage	Compliant to EN 50155	16	-	67	V
Input Current		-	-	14	A
Input Current (no load)	Vin = 48 V, Ta = 25°C	-	100	150	mA
Input Reflected Ripple Current (rms)	With simulated source impedance of 12 μH, 5 Hz to 20 MHz. Use a 47 μF/100 V electrolytic capacitor with ESR = 1 ohm max, at 25°C.	-	-	15	mA
Input Reflected Ripple Current (pk-pk)		-	-	40	mA
Under-voltage Turn on Voltage Threshold	Lockout turn on	14.5	15.2	16	V
Under-voltage Turn off Voltage Threshold	Lockout turn off, non-latching	12.5	13.2	14	V
Over-voltage Shutdown Threshold	Auto-recovery and non-latching.	69	70	71	V
Over-voltage Recovery Threshold		68	69	70	V

CAUTION: All protection features are non-latching with auto-restart when fault is removed.

4. OUTPUT SPECIFICATIONS

All specifications are typical at nominal input, full load at 25°C unless otherwise stated.

PARAMETER	DESCRIPTION	MIN	TYP	MAX	UNIT
Output Voltage Set Point	Test condition of the output set point: Vin = 48 V, Io = 100% load at 25°C ambient.	53	54	55	V
Load Regulation		-	50	100	mV
Line Regulation		-	50	100	mV
Regulation Over Temperature		-	±200	±350	%/°C
Ripple and Noise (pk-pk)	40 kHz - 100 MHz BW, with 0.1 μF ceramic capacitor and 1000 μF bulk electrolytic at output.	-	-	300	mV
Ripple and Noise (rms)		-	-	100	mV
Output Current Range		0	-	3	A
Output DC Current Limit	Enter a hiccup mode, non-latching.	3.3	3.7	4.5	A
Rise Time	Vin = 48 V, Io = 3 A, with 1000 μF bulk electrolytic at output.	-	0.05	0.1	s
Start-up Time (from Venable and Vin)		-	-	2	s
Overshoot at Turn on		-	0	3	%
Undershoot at Turn off		-	0	3	%
Output Capacitance		200	-	1000	μF
Transient Response					
ΔV 50%~75% of Max Load		-	-	2	%Vout
Settling Time	di/dt = 0.1 A/μs, with 1000 μF bulk electrolytic at output.	-	-	3	ms
ΔV 75%~50% of Max Load		-	-	2	%Vout
Settling Time		-	-	3	ms



Asia-Pacific
+86 755 298 85888

Europe, Middle East
+353 61 225 977

North America
+1 408 785 5200

© 2021 Bel Power Solutions & Protection

BCD.20073_AK

5. GENERAL SPECIFICATIONS

Notes: All specifications are typical at 25 °C unless otherwise stated.

PARAMETER	DESCRIPTION	MIN	TYP	MAX	UNIT
Efficiency	Io = 60% - 100% Irate	88	90	-	%
	Io = 40% - 60% Irate	86	88	-	%
Switching Frequency		-	200	-	kHz
Output Voltage Trim Range		50	-	56	V
Over Temperature Protection	Baseplate temperature.	-	120	-	°C
Over Voltage Protection(Static)	Enter a latching. non-hiccup mode	57.5	58	58.5	V
FIT	Calculated Per IEC 62380 TR 1 (Utec 80-810) (Vin = 24 V, Vo = 54 V, Io = 3 A, 0 LFM,	-	177.58	-	-
MTBF	Tac = 50°C, Tae = 35°C)	-	5.63	-	Mhrs
Weight		-	68	-	g
Dimensions (L x W x H)		2.30 x 1.45 x 0.59			inch
		58.42 x 36.83 x 15.0			mm
Isolation Characteristics					
Input to Output		-	-	2250	V
Input to Heatsink		-	-	2250	V
Output to Heatsink		-	-	2250	V
Isolation Resistance		10M	-	-	Ohm
Isolation Capacitance		-	-	3900	pF

6. EFFICIENCY DATA

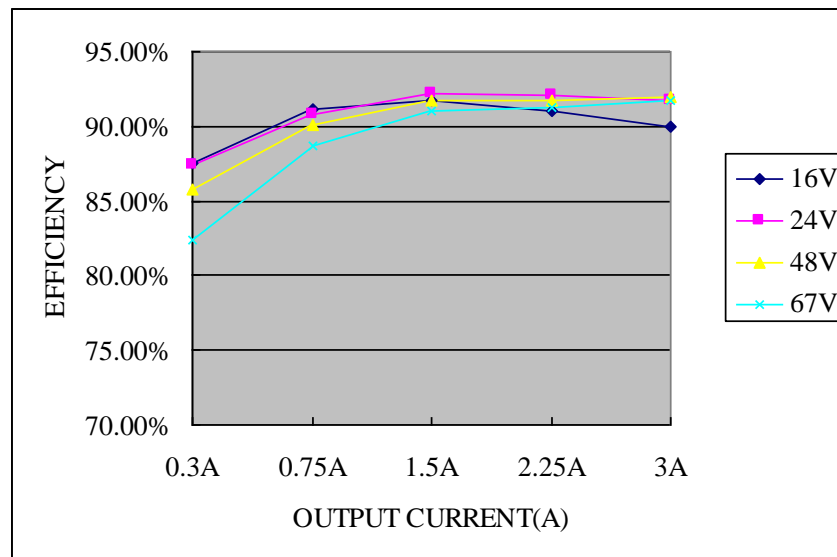

Figure 1. Efficiency data

7. REMOTE ON/OFF

PARAMETER	DESCRIPTION	MIN	TYP	MAX	UNIT
Signal Low (Unit On)	Active Low	-0.3	-	0.8	V
Signal High (Unit Off)		2.4	-	15	V
Current Sink		0	-	1	mA

Recommended remote on/off circuit for active low

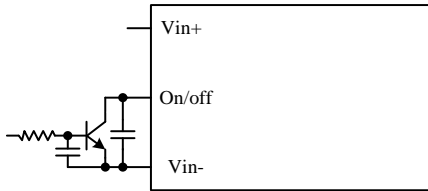

Figure 2. Control with open collector/drain circuit

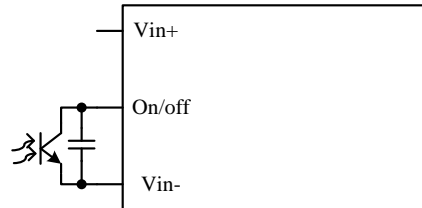

Figure 3. Control with photocoupler circuit

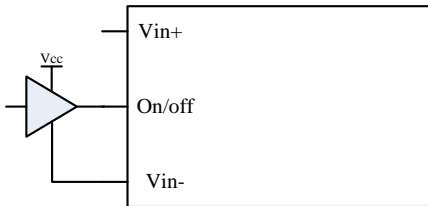

Figure 4. Control with logic circuit

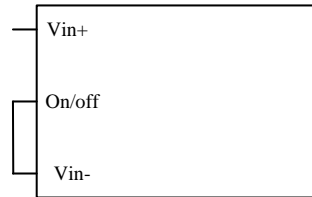

Figure 5. Permanently on

8. REMOTE SENSE

This module has remote sense compensation feature. It can minimize the effects of resistance between output and load in system layout and facilitate accurate voltage regulation at load terminals or other selected point.

1. The remote sense lines carry very little current and hence do not require a large cross-sectional area.
2. This module compensates for a maximum drop of 4% of the nominal output voltage.
3. If the unit is already trimmed up, the available remote sense compensation range should be correspondingly reduced. The total voltage increased by trim and remote sense should not exceed 4% of the nominal output voltage.
4. When using remote sense compensation, all the resistance, parasitic inductance and capacitance of the system are incorporated within the feedback loop of this module which can make an effect on the module's compensation, affecting the stability and dynamic response. A 0.1 μF ceramic capacitor can be connected at the point of load to de-couple noise on the sense wires.
5. Recommend the connection of remote sense compensation as below figure. There are a resistor R_{S+} (100 ohm) from V_{O+} to Sense+ and a resistor R_{S-} (100 ohm) from V_{O-} to Sense- inside of this module.

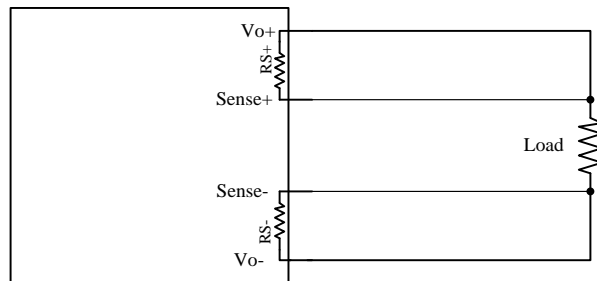

Figure 6.

6. If not using remote sense compensation, please connect sense directly to output at module's pin, that is, connect sense+ to V_{O+} and sense- to V_{O-} at module's pin, the shorter the better. see below figure.

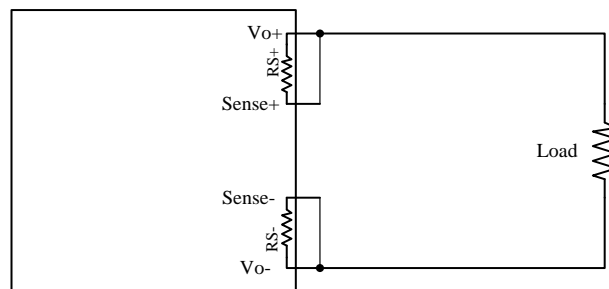
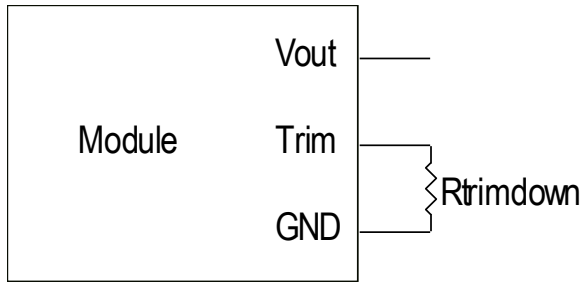

Figure 7.

9. TRIM

Trim down test circuit



$$R_{trimdown} = \frac{V_{o_req}}{54 - V_{o_req}} - 1 [k\Omega]$$

Figure 8. Trim down test circuit

Trim up test circuit

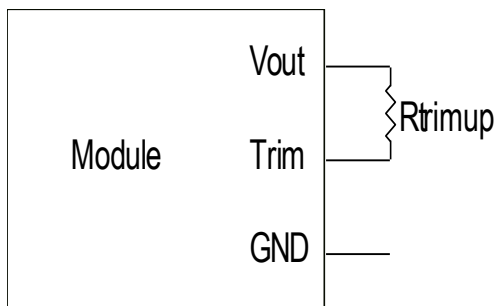

$$R_{trimup} = \frac{1 - 0.02296}{0.02296 - 1.24 / V_{o_req}} - 1 [k\Omega]$$

Figure 9. Trim up test circuit

Note: Vo_req = Desired(trimmed) output voltage[V]

10. THERMAL DERATING CURVES

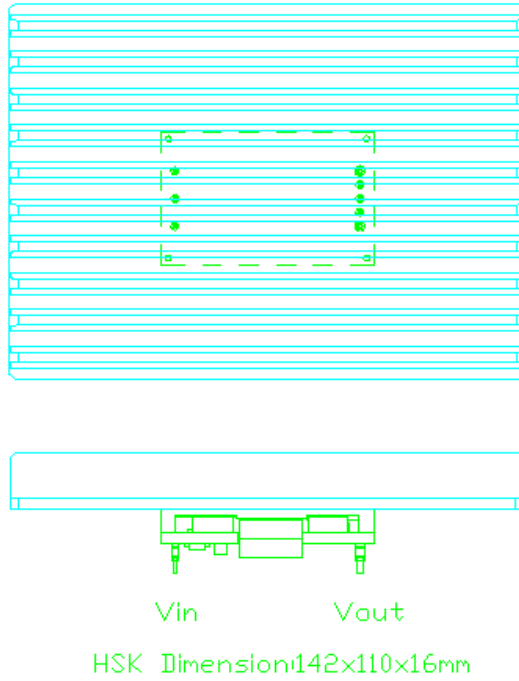

Figure 10. Thermal test setup

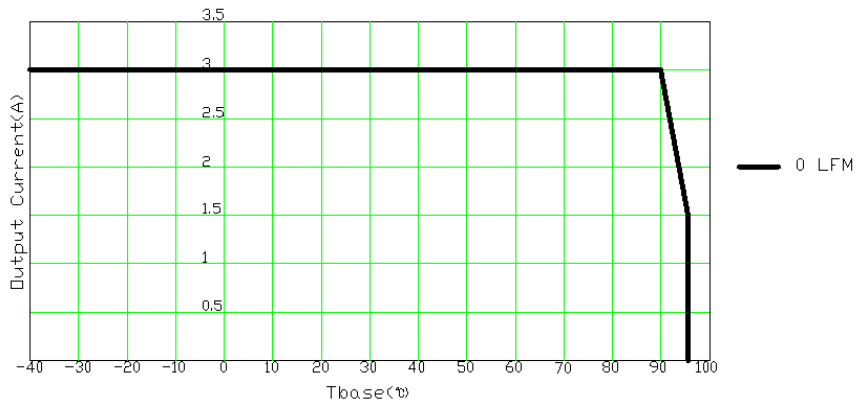

Figure 11. Thermal derating curve

11. MECHANICAL DIMENSIONS

OUTLINE

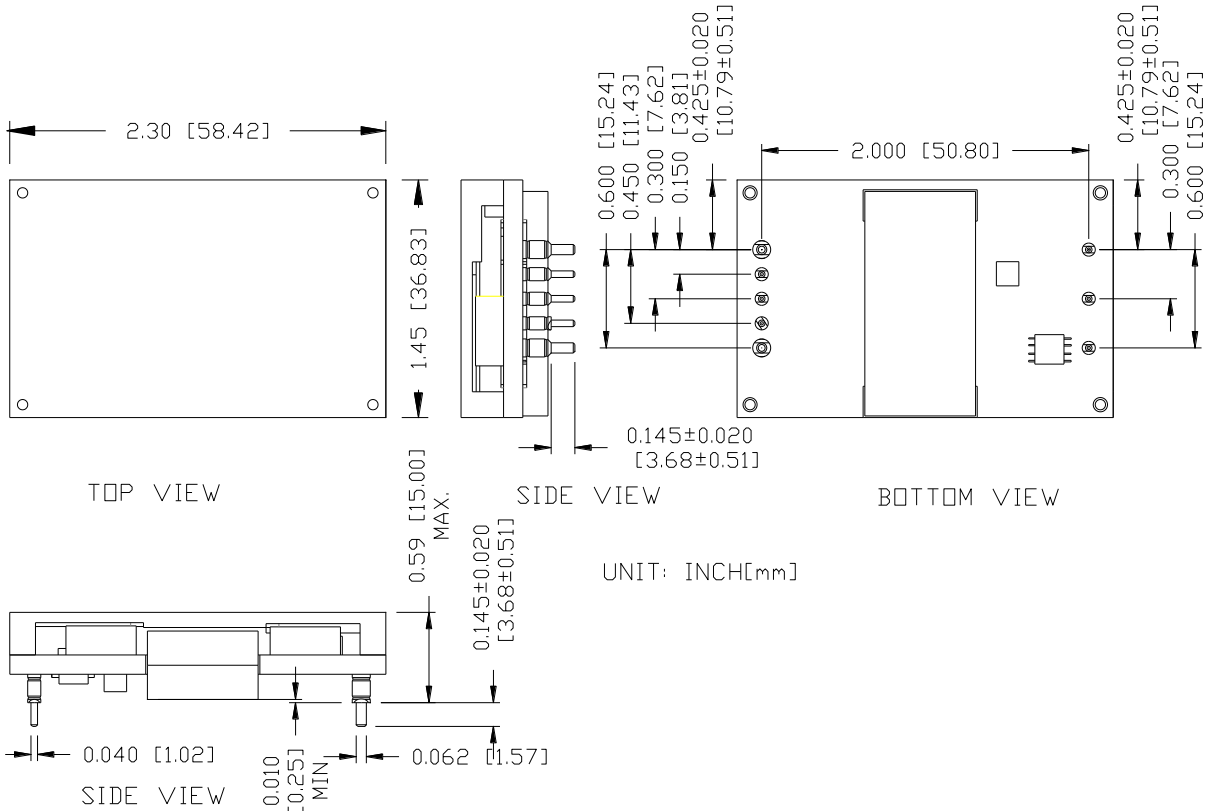

Figure 12. Outline

Note: This module is recommended and compatible with Pb-Free Wave Soldering and must be soldered using a peak solder temperature of no more than 260 °C for less than 5 seconds.

NOTES:

- 1) All Pins: Material - Copper Alloy;
Finish – Gold plated
- 2) Un-dimensioned components are shown for visual reference only.
- 3) All dimensions in inch [mm]; Tolerances: x.xx +/-0.02 inch [0.51 mm]. x.xxx +/-0.010 inch [0.25 mm].

PIN DEFINITIONS

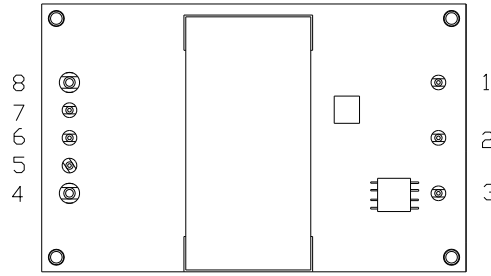

Figure 13. Pins

PIN	FUNCTION	PIN	FUNCTION
1	Vin (+)	5	Sense (-)
2	ON/OFF	6	Trim
3	Vin (-)	7	Sense (+)
4	Vout (-)	8	Vout (+)

RECOMMENDED PAD LAYOUT

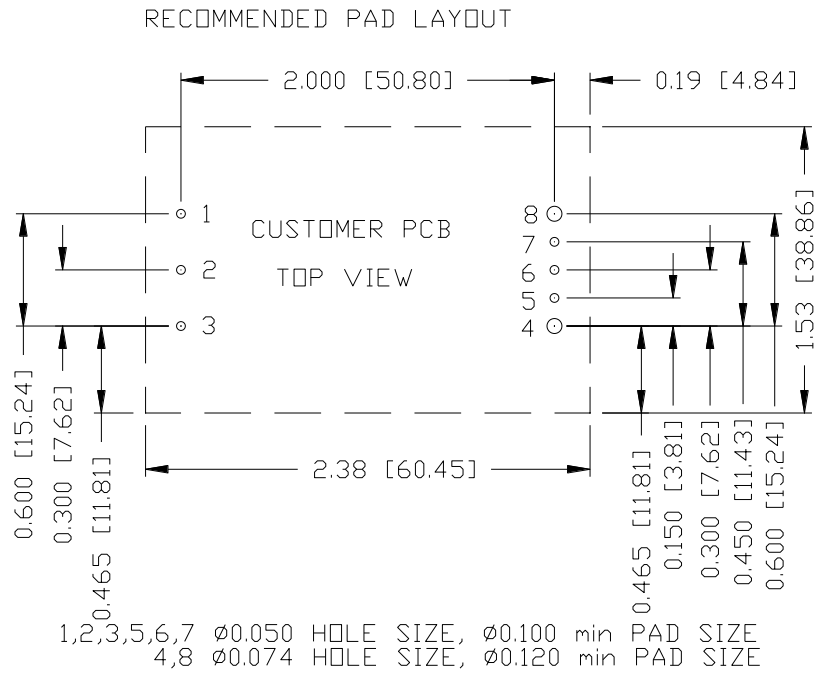

Figure 14. Recommended pad layout

12. REVISION HISTORY

DATE	REVISION	CHANGES DETAIL	APPROVAL
2014-01-27	A	First release	J.Yan
2014-4-11	B	Update Cover	J.Yan
2014-10-17	C	Update TD	J.Yan
2014-11-13	D	Update General Specifications, TD	J.Yan
2014-12-24	E	Update MTBF and FIT	J.Yan
2015-2-10	F	Update MD	J.Yan
2016-02-26	G	Update Absolute maximum rating	J.Yan
2016-04-21	H	Update Safety Certification, MTBF, Thermal Derating Curve.	J.Yan
2017-09-27	AI	Update the form.	J.Yan
2018-7-16	AJ	Add application of railways.	J.Yao
2021-05-14	AK	Add object ID. Update safety certificate, mechanical outline and recommended pad layout.	J.Yao

For more information on these products consult: tech.support@psbel.com

NUCLEAR AND MEDICAL APPLICATIONS - Products are not designed or intended for use as critical components in life support systems, equipment used in hazardous environments, or nuclear control systems.

TECHNICAL REVISIONS - The appearance of products, including safety agency certifications pictured on labels, may change depending on the date manufactured. Specifications are subject to change without notice.



Asia-Pacific
+86 755 298 85888

Europe, Middle East
+353 61 225 977

North America
+1 408 785 5200

© 2021 Bel Power Solutions & Protection

BCD.20073_AK

Please read our datasheet & drawing disclaimer [here](#).