

THIS DRAWING AND THE SUBJECT MATTER SHOWN THEREON ARE CONFIDENTIAL AND THE PROPERTY OF BEL/STEWART/TRP CONNECTOR AND SHALL NOT BE REPRODUCED, COPIED, OR USED IN ANY MANNER WITHOUT THE WRITTEN CONSENT OF TRP CONNECTOR.

PRODUCT MAY BE PROTECTED BY ONE OR MORE OF THE FOLLOWING US PATENTS:  
 5736910 5939955 6425781 6428361 6554638 6840817 7123117  
 7429195 7717749 7808751 6217391 6149050 7924130

REVISIONS				
P	LTN	DESCRIPTION	DATE	APPROV
3		SEE LAST SHEET	14JAN2015	RL TY

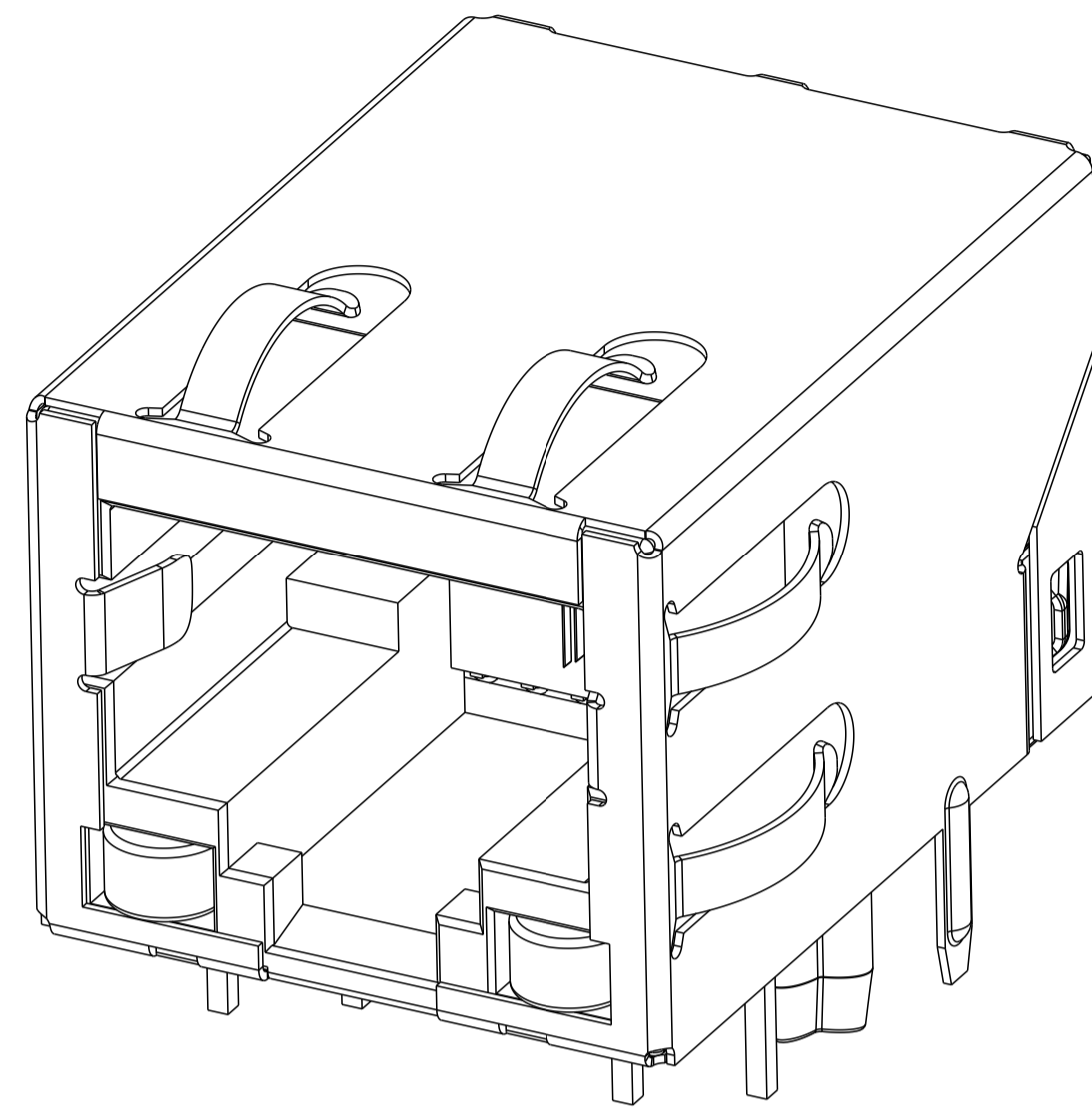
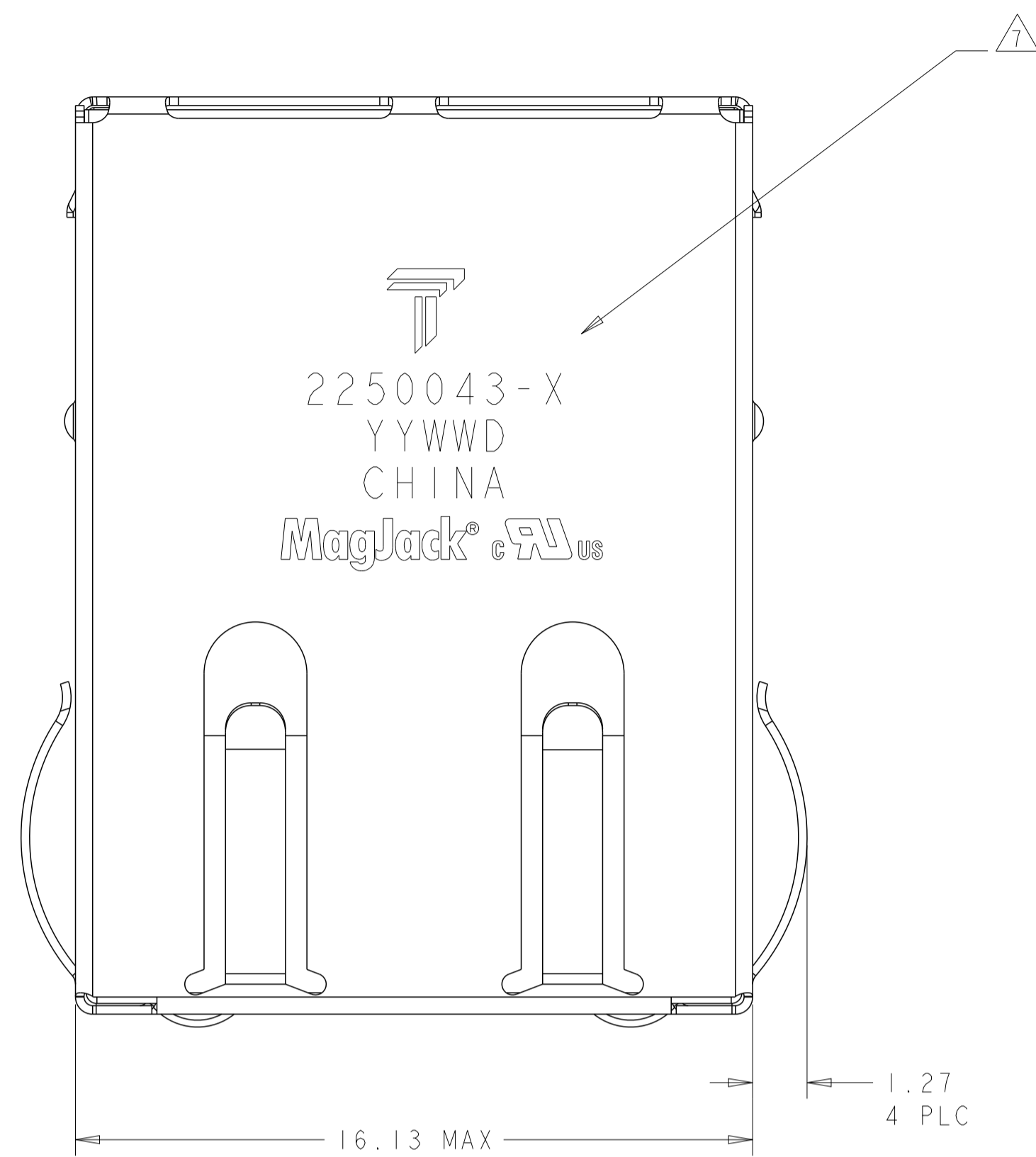

1. MATERIALS
- HOUSING: THERMOPLASTIC, FLAMMABILITY RATING UL 94V-0.
  - SHIELD: BRASS 0.20mm THICK, PREPLATED WITH 0.76um MIN SEMI-BRIGHT NICKEL. SOLDER TABS POST DIPPED WITH 2.54um MIN SAC SOLDER.
  - CONTACTS: PHOSPHOR BRONZE 0.46mm X 0.30mm, PHOSPHOR BRONZE, 1.27um MIN NICKEL UNDERPLATE, WITH 1.27um MIN GOLD PLATING AT MATING INTERFACE AND 2.54um MIN MATTE TIN ON SOLDER TAILS.
  - SOLDER TAILS: 0.25mm THICK, PHOSPHOR BRONZE, 1.27um MIN OVERALL NICKEL UNDERPLATE, 3um TIN PLATE
  - LIGHT EMITTING DIODE (LED): DIFFUSED EPOXY LENS, 0.5mm X 0.5mm CARBON STEEL WIREFRAME LEADS PREPLATED WITH 2.03um MIN. SILVER PLATE OVER 1.02um MIN. NICKEL OVER 1.02um MIN. COPPER UNDERPLATE; LEADS POST-PLATED WITH 3.05um MIN. MATTE TIN AND/OR SAC SOLDER DIP OR PURE TIN SOLDER DIP

2. RJ45 JACK CAVITY CONFORMS TO FCC RULES AND REGULATIONS PART 68 SUB PART F.

3. MAGNETICS
- APPLICATION: 10/100 BASE-T
  - IMPEDANCE: 100 OHMS
  - TURNS RATIO (CHIP:CABLE): TX = 1:1, RX = 1:1
  - OPEN CIRCUIT INDUCTANCE (OCL): 350uH MIN @100kHz, 0.1VRMS, 8mADC BIAS FROM 0°C TO +70°C, TX AND RX
  - PERFORMANCE @ 25°C:
  - INSERTION LOSS (IL): 1.1dB MAX FROM 0.5MHz TO 100MHz
  - RETURN LOSS (RL): 18dB MIN FROM 0.5MHz TO 30MHz
  - 18-20LOG(f/30)dB MIN FROM 30.1MHz TO 60MHz
  - 12dB MIN FROM 60.1MHz TO 80MHz
  - CROSSTALK ATTENUATION: 35dB MIN FROM 0.5MHz TO 40MHz
  - 33-20LOG(f/50)dB MIN FROM 40.1MHz TO 100MHz
  - COMMON MODE REJECTION RATIO (CMRR): 30dB MIN FROM 0.5MHz TO 100MHz
  - ISOLATION VOLTAGE: 2250VDC FOR 60 SECONDS WITH A RISE TIME OF 500 V/SEC

4. OPERATING TEMPERATURE: FROM 0°C TO +70°C.

5. INDICATED MAGNETIC CONNECTIONS ARE SYMMETRICAL TO SUPPORT AUTO-MDI/MDIX.

6. LEDS WITH BUIL-IN 250 OHM RESISTORS. LEDS ARE DRIVEN WITH 5V VOLTAGE AND THE MAX OPERATING CURRENT IS 20mA

LED COLOR: DOMINATE WAVELENGTH (λD): GREEN 568 nm TYP. @ VF=5V  
 FORWARD CURRENT (IF): GREEN 12mA TYP @ VF = 5V  
 DOMINATE WAVELENGTH (λD): YELLOW 588 nm TYP. @ VF=5V  
 FORWARD CURRENT (IF): YELLOW 13mA TYP @ VF = 5V

7. TRP CONNECTOR LOGO, PART NUMBER, DATE CODE, COUNTRY OF ORIGIN AND AGENCY APPROVAL MARKING IN APPROXIMATE LOCATION SHOWN.

8. THIS PART IS RECOMMENDED FOR WAVE SOLDERING PROCESS, PREHEAT TEMPERATURE IS 120°C TO 160°C, 120 SECONDS TO 180 SECONDS, PEAK WAVE SOLDERING TEMPERATURE IS 260°C MAX, 10 SECONDS MAX.

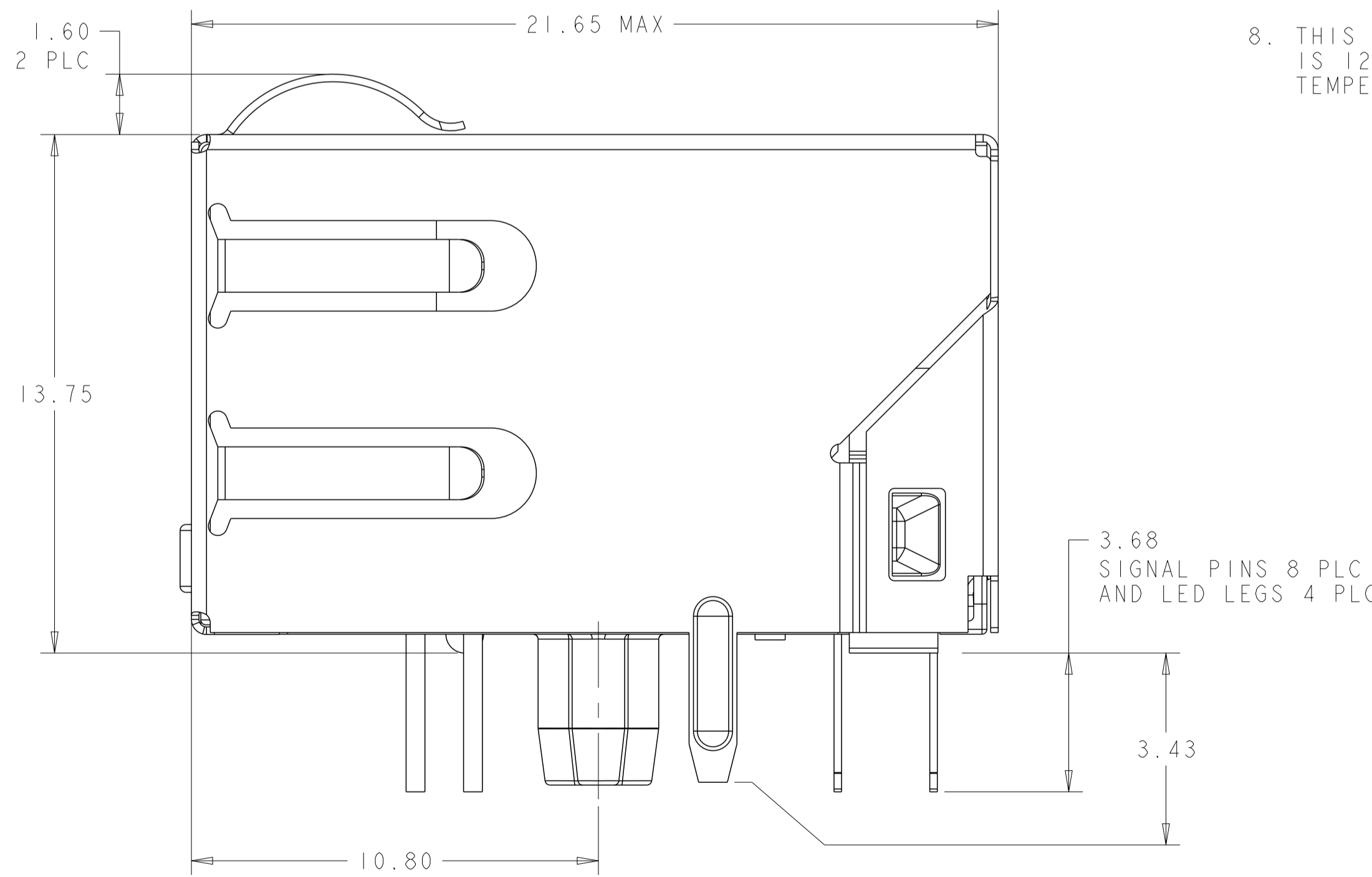
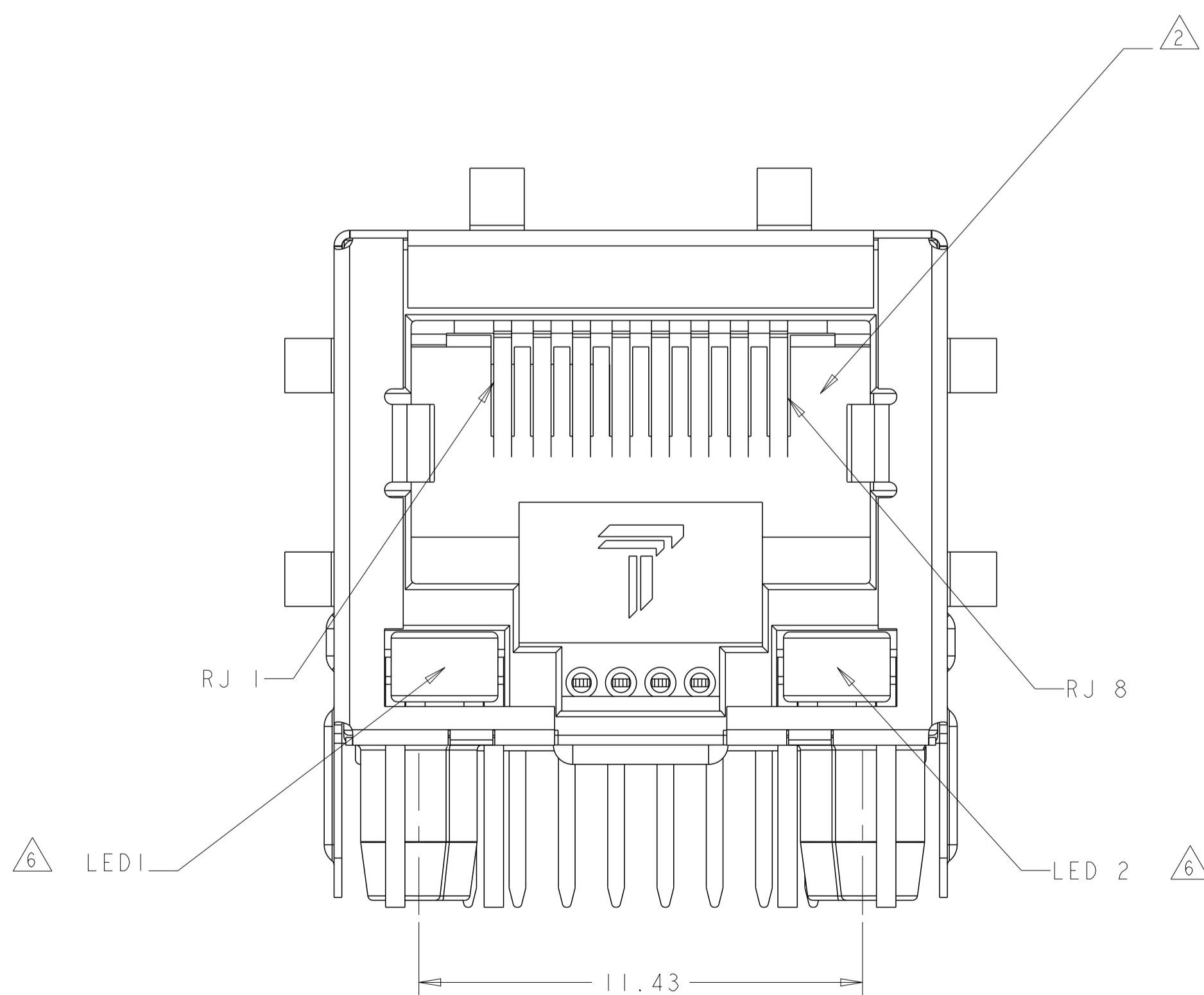

GREEN	YELLOW	2250043-1
9 → 10	11 → 12	PART NUMBER
LED 1	LED 2	

THIS DRAWING IS A CONTROLLED DOCUMENT.		OWN: ROY LIU 05JUN2013	 <b>trp CONNECTOR</b> a bel group	DONGGUAN CHINA
DIMENSIONS: mm		CHK: TOWER YU/FRANK LIU 05JUN2013		DESC: 1X1 326PI 10/100 TAB DOWN W/ LED
TOLERANCES UNLESS OTHERWISE SPECIFIED:		APPV: TONY YUAN 05JUN2013	RESTRICTED TO	
0 PLC ±0.25 1 PLC ±0.25 2 PLC ±0.25 3 PLC ±0.25 4 PLC ±0.25 ANGLES ±° APPLICATION SPEC ±°		MODEL NAME: MAGJACK	SIZE: A1	CAGE CODE: C=2250043
PRODUCT SPEC: 108-104004		PRODUCT SPEC: SINGLE Non-PoE	SCALE: 4:1	SHEET 1 OF 3 REV 3
CUSTOMER DRAWING				

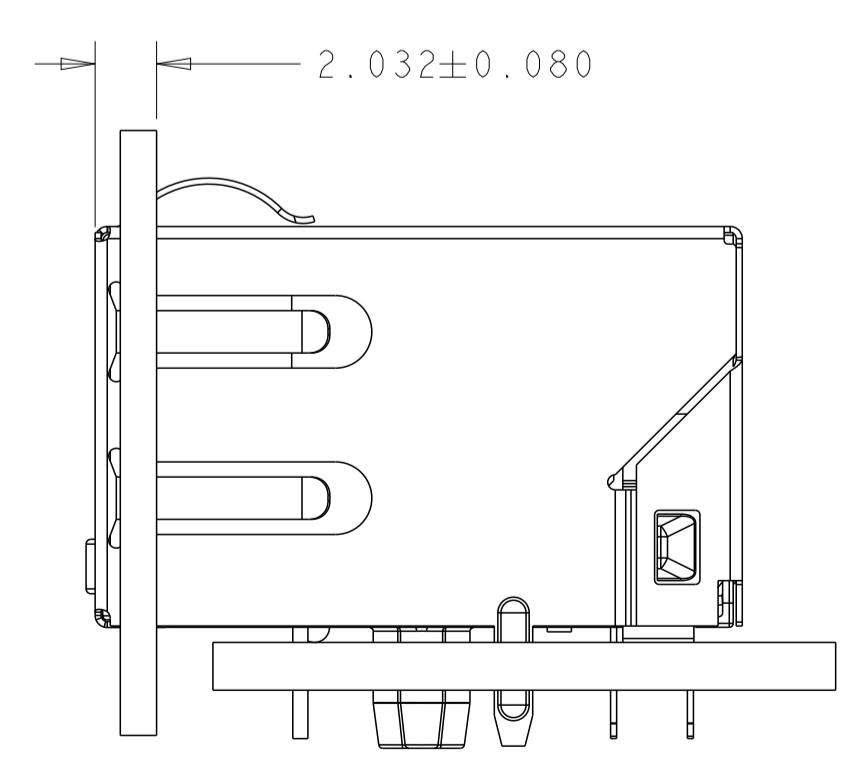
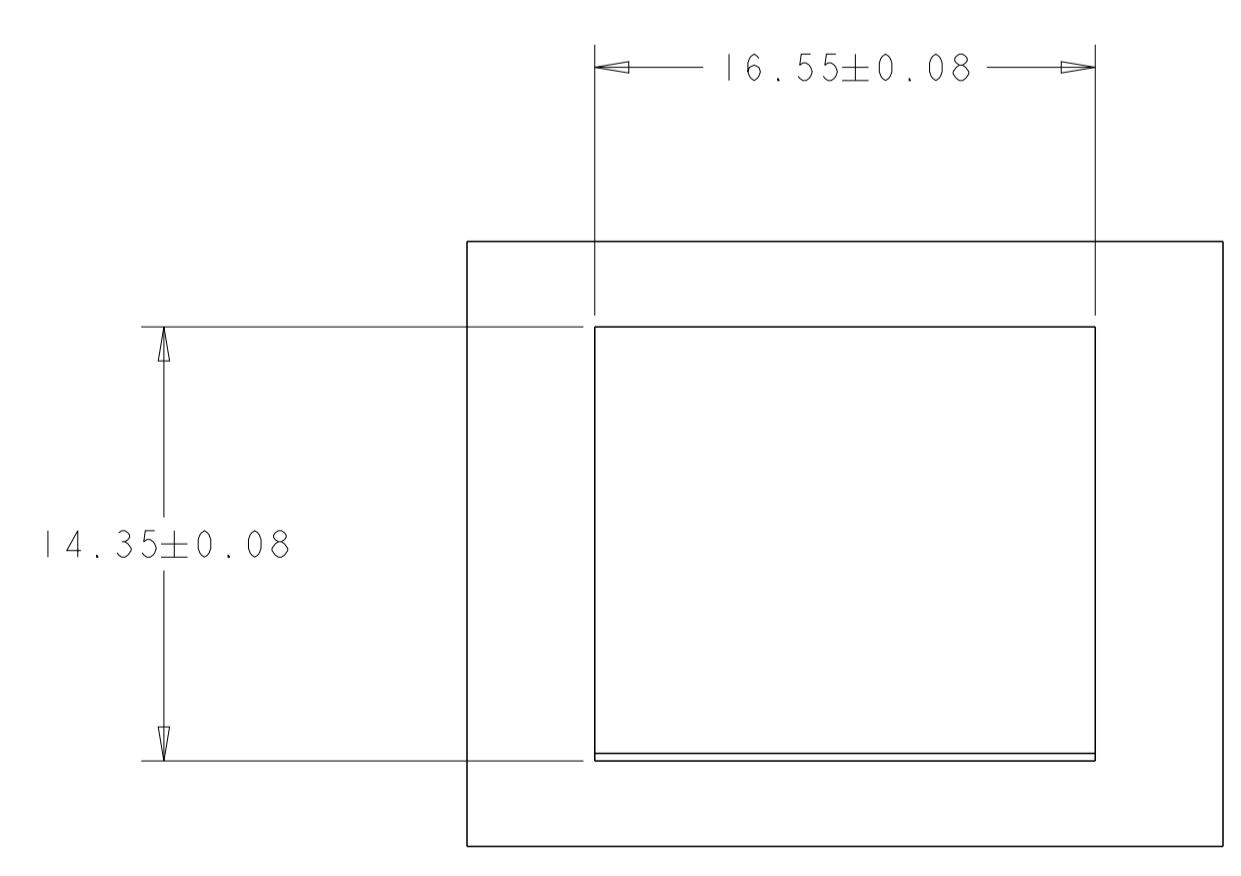
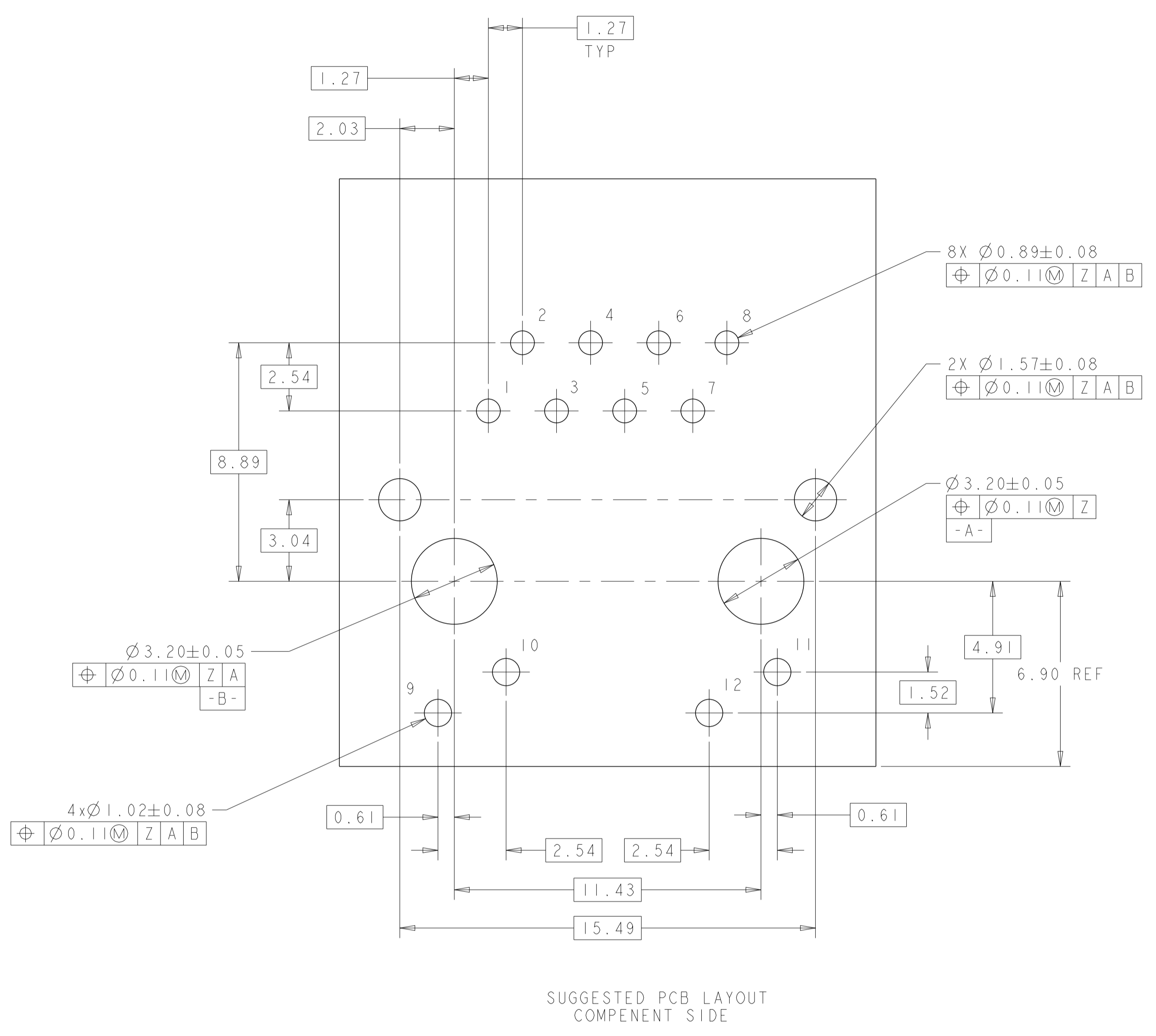

### 326PI 10/100 BASE-T CIRCUIT

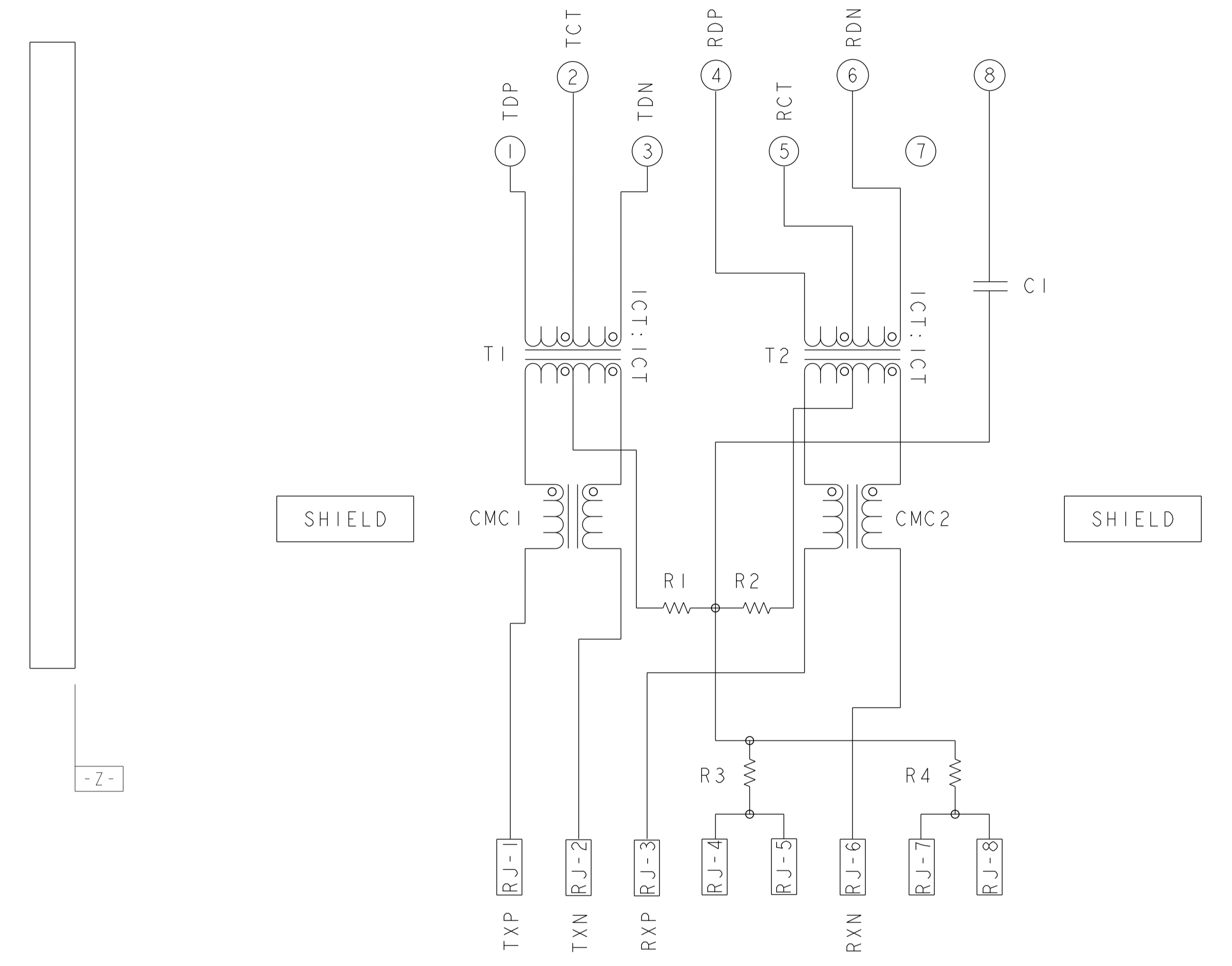

C1= 1000pF, 2kV CAPACITOR  
 R1-R4= 75 Ohms, RESISTORS

THIS DRAWING IS A CONTROLLED DOCUMENT.		OWN ROY LIU	05JUN2013	 <b>trp</b> CONNECTOR a bel group DONGGUAN CHINA
DIMENSIONS:		CHK TOWER YU/FRANK LIU	05JUN2013	
mm		APP'D TONY YUAN	05JUN2013	
0 PLC $\pm 0.25$ 1 PLC $\pm 0.25$ 2 PLC $\pm 0.25$ 3 PLC $\pm 0.25$ 4 PLC $\pm 0.25$ ANGLES $\pm 0.1$ APPLICATION SPEC $\pm 0.1$		MODEL NAME MAGJACK	DESC 1X1 326PI 10/100 TAB DOWN W/ LED	
PRODUCT SPEC 108-104004		SINGLE Non-PoE		SIZE A1
		CUSTOMER DRAWING		RESTRICTED TO -
		SCALE 4:1		SHEET 2 OF 3
				REV 3

C_2250043						STOCK DISPOSITION			
REVISION HISTORY						A: CONTINUE AS IS	D: USE OLD FIRST		
						B: REWORK	E: PARTS TO CONFORM		
						C: SCRAP	F: OTHER		
DATE	REV	CHANGES	REASON	APPROVAL	INVENTORY (A,B,C,D,E,F)	WORK IN PROCESS (A,B,C,F)	SUPPLIER ORDERS (A,E,F)	OPEN CUST ORDERS (A,E,F)	
05JUN2013	1	-	INITIAL RELEASE	TONY YUAN	-	-	-	-	
12MAR2014	2	SHEET2, C6: EXCHANGE THE NUMBER OF LED 2' LEGS (11 & 12)	ERROR CORRECTION	TONY YUAN	-	-	-	-	
14JAN2015	3	EC-1411035 COMPANY LOGO CHANGE	MARKET REQUIREMENT	TONY YUAN	-	-	-	-	

THIS DRAWING IS A CONTROLLED DOCUMENT.		OWN ROY LIU	05JUN2013	 <b>TRP CONNECTOR</b> a bel group	DONGGUAN CHINA	
DIMENSIONS:		CHK TOWER YU/FRANK LIU	05JUN2013		DESC IX1 326PI 10/100 TAB DOWN W/ LED	
mm		APVD TONY YUAN	05JUN2013		RESTRICTED TO	
0 PLC ±0.25 1 PLC ±0.25 2 PLC ±0.25 3 PLC ± 4 PLC ± ANGLES ± APPLICATION SPEC ±		MODEL NAME MAGJACK		SIZE A1	CAGE CODE C=2250043	
PRODUCT SPEC 108-104004		APPLICATION SPEC -		CUSTOMER DRAWING		
				SCALE 4:1	SHEET 3 OF 3	
				REV 3		