

THE INFORMATION CONTAINED HEREIN IS CONSIDERED "PROPRIETARY" TO BEL FUSE INC. AND SHALL NOT BE COPIED, REPRODUCED OR DISCLOSED WITHOUT THE WRITTEN APPROVAL OF BEL FUSE INC.

ELECTRICAL CHARACTERISTICS @ 25°C

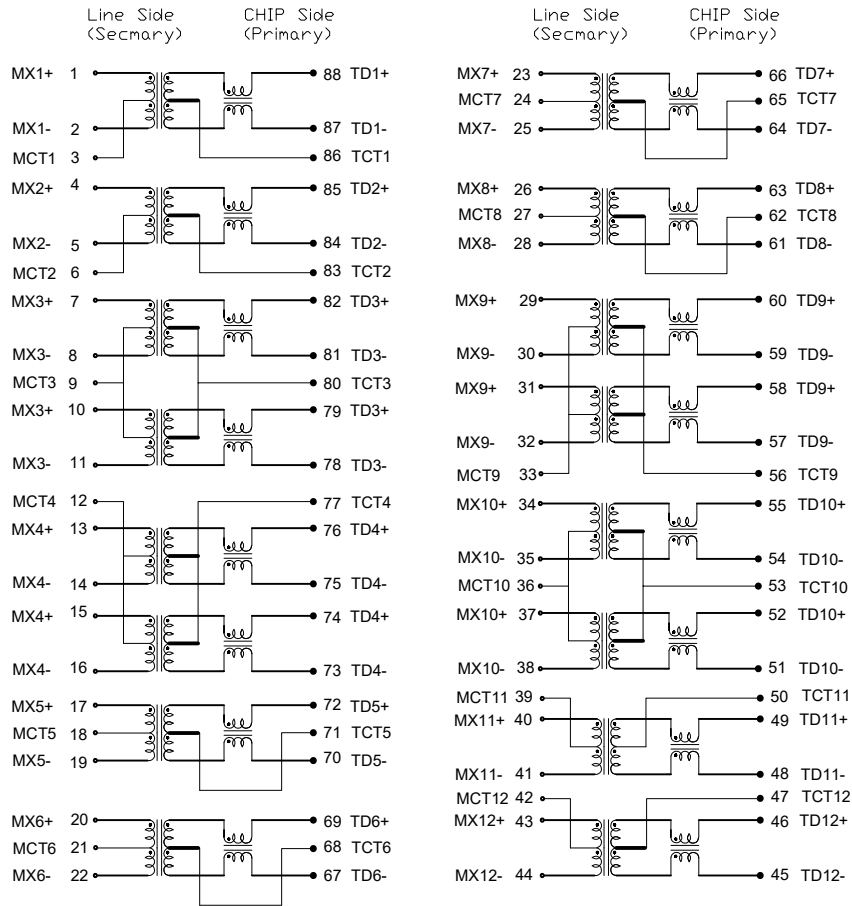

SCHEMATIC



URNS RATIO

Tx SIDE: 1CT : 1CT
 □CL 350uH Min.
 @100KHz,100mV,WITH 8mA DC BIAS.

PIN(1-2),(4-5),(7-8),(10-11),(13-14),(15-16),(17-19),(20-22)
 PIN(23-25),(26-28),(29-30),(31-32),(34-35),(37-38),(40-41),(43-44)

INSERTION LOSS -1.0dB MAX. @ 1MHz TO 100MHz

RETURN LOSS -18dB MIN. @ 1-30MHz
 MEASURED UNDER A -14.4dB MIN. @ 40MHz
 100 ENVIRONMENT -13.1dB MIN. @ 50MHz

-12dB MIN. @ 60-80MHz
 -10dB MIN. @ 80-100MHz

CROSSTALK -30dB MIN. AT 1MHz TO 100MHz

CMRR -30dB MIN. AT 1MHz TO 100 MHz

HIPOT LEAKAGE CURRENT LESS THAN 1mA AT 1500VAC

Applicable Operating temp 0°C~+70°C

Suitable for End-span PoE applications with 720mA current capability

REV. : A/2 PAGE : 1

ORIGINATED BY	DATE
yan bin zhang	2026-5-29
DRAWN BY	DATE
ting shu yang	2026-5-29

TITLE
Electrical specification QUAD 1000BASE-T module

PART NO. / DRAWING NO.
0558-5999-FB
FILE NAME
0558-5999-FB_A.DWG

STANDARD DIM.	METRIC DIM. AS REF.
TOL. MM	UNIT : mm[INCH]
.X	SCALE : N/A
.XX	SIZE : A4
.XXX	

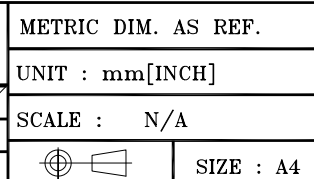

THE INFORMATION CONTAINED HEREIN IS CONSIDERED "PROPRIETARY" TO BEL FUSE INC. AND SHALL NOT BE COPIED, REPRODUCED OR DISCLOSED WITHOUT THE WRITTEN APPROVAL OF BEL FUSE INC.

RoHS

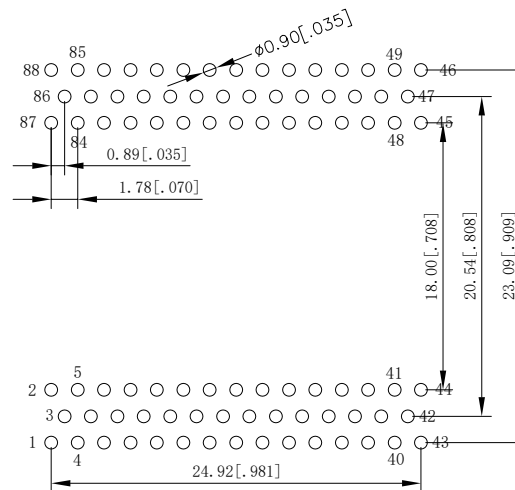
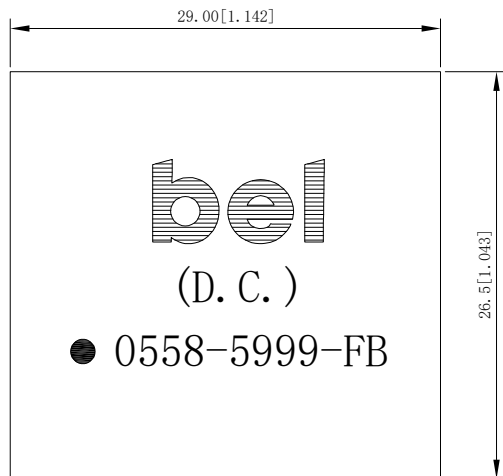

SUGGESTED PCB LAYOUT

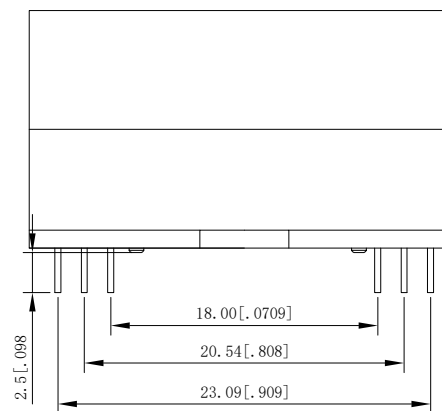
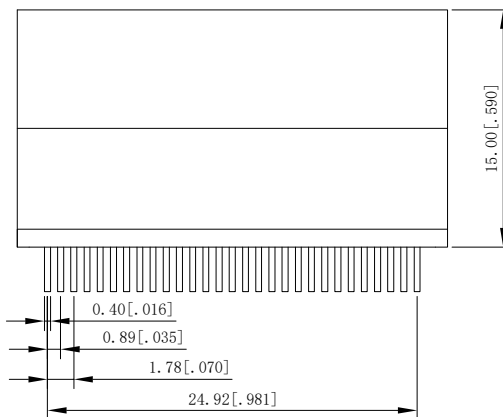

REV. : A/2

PAGE : 2

ORIGINATED BY	DATE
yan bin zhang	2026-5-29
DRAWN BY	DATE
ting shu yang	2026-5-29

TITLE
Electrical specification
QUAD 1000BASE-T module

PART NO. / DRAWING NO.	STANDARD DIM.
0558-5999-FB	TOL. MM
FILE NAME	.X
0558-5999-FB_A.DWG	.XX ±0.25
	.XXX ±0.127

METRIC DIM. AS REF.
UNIT : mm[INCH]
SCALE : N/A
SIZE : A4



THE INFORMATION CONTAINED HEREIN IS CONSIDERED "PROPRIETARY" TO BEL FUSE INC. AND SHALL NOT BE COPIED, REPRODUCED OR DISCLOSED WITHOUT THE WRITTEN APPROVAL OF BEL FUSE INC.

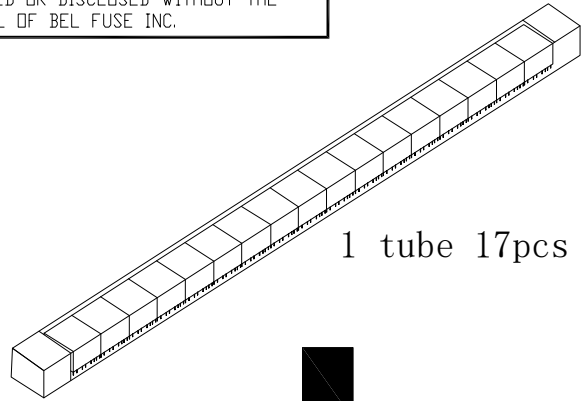

1 tube 17pcs

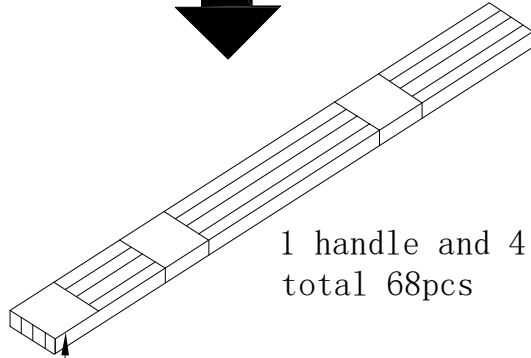
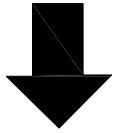

1 handle and 4 tubes
total 68pcs

PRODUCT LABEL

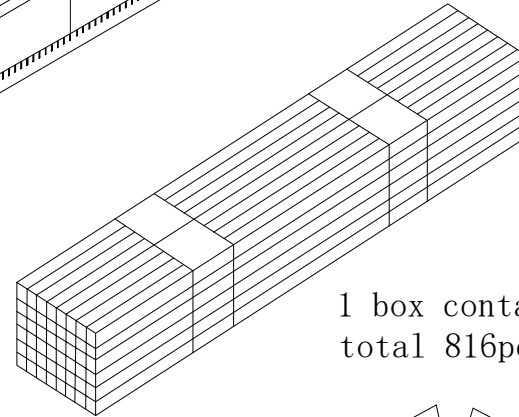
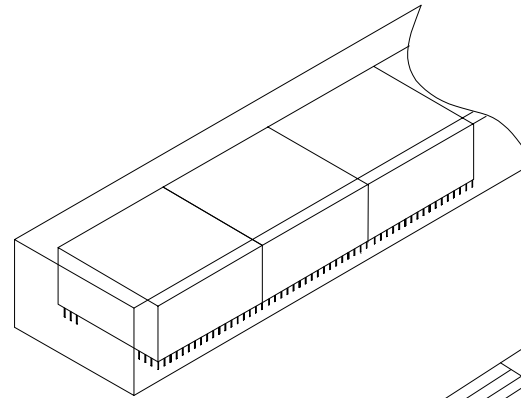
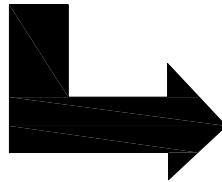

1 box contains 12 handfuls
total 816pcs

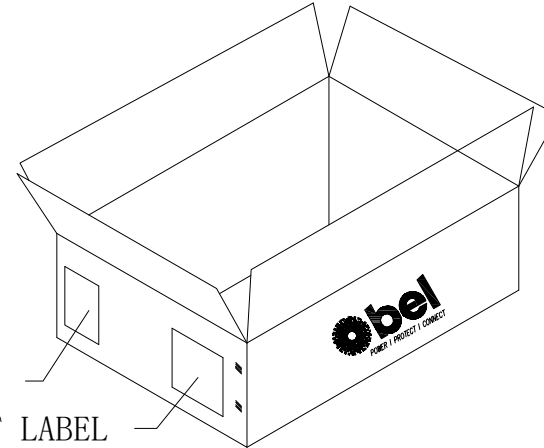

SHIPPING LABEL

PRODUCT LABEL

REV. : A/2 PAGE : 3

ORIGINATED BY yan bin zhang	DATE 2026-5-29	TITLE PACKING SPECIFICATION FOR 0558-5999-FB	PART NO. / DRAWING NO. 0558-5999-FB	STANDARD DIM. TOL. MM	METRIC DIM. AS REF.
DRAWN BY ting shu yang	DATE 2026-5-29		FILE NAME 0558-5999-FB_A.DWG	.X .XX .XXX	UNIT : mm[INCH] SCALE : N/A SIZE : A4

