

X Series

375, 500 Watt AC-DC & DC-DC DIN-Rail Converters Convert Select

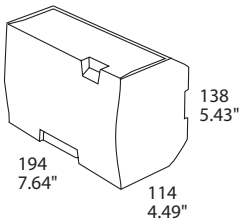

Features

- RoHS lead-free-solder and lead-solder-exempted products are available
- Rugged 35 mm DIN-rail snap-fit design
- Class I equipment
- Universal AC-input with single stage conversion AC-DC or DC-DC, input 100–240 VAC or 90–350 VDC
- Power factor correction, harmonics IEC/EN 61000-3-2
- Virtually no inrush current
- Immunity to IEC/EN 61000-4-2, -3, -4, -5, -6, -8, -11
- Emissions according to EN 55011/55032
- Very high efficiency; up to 89%
- Short-term output peak power capability, rectangular current limiting characteristic
- Single or two independently regulated outputs with 24, 36, or 48 V
- Outputs no-load, overload, and short-circuit proof
- PCBs protected by lacquer
- Very high reliability
- Product version V106
- Safety according to IEC/EN 62368-1, UL/CSA 60950-1

Table of Contents

Description.....	2	Immunity to Environmental Conditions.....	14
Model Selection.....	2	Mechanical Data.....	16
Functional Description.....	4	Safety and Installation Instructions.....	17
Electrical Input Data.....	6	Description of Options.....	20
Electrical Output Data.....	8	Accessories.....	25
Electromagnetic Compatibility (EMC).....	13	Battery Charging /Temperature Sensor.....	26

Description

The Convert Select front end series represents a family of DIN-rail mountable DC-DC and AC-DC converters with power factor correction. The converters have been designed according to the latest industry requirements and standards. They are ideal for use in outdoor and other demanding applications to power building control systems, factory automation, industrial controls, instrumentation, electromagnetic drives, fans, and other DC loads. Different models are available with a single output or two independently regulated, electrically isolated outputs with 24, 36, or 48 V. Special models for battery charging are available.

Key features of the Convert Select line include power factor correction with low harmonic distortion, negligibly low inrush current, high immunity to transients and surges, and low electromagnetic emissions. Internal protection circuits such as input over- and undervoltage lockout, thermal protection, as well as output overvoltage protection by a second control loop ensure safe operation of the final system.

The outputs deliver an electrically-isolated Electrical energy source class 1 (ES1), (except models LXR/LXN1740) and low output noise. They are no-load, overload, and short-circuit proof. The electronically controlled short-term peak power capability of up to 150% of the rated output power enables the front end converters to deliver additional power to start-up motors or to safely operate subsequent circuit breakers. Built-in large sized output capacitors absorb possible reverse energy, which may be caused by quick deceleration of electromagnetic drives connected directly to the output. A green LED at the front cover displays the status of the output(s).

The Convert Select Series was designed according to all relevant international safety standards. Adequate clearances and creepage distances allow operation in pollution degree 2 environment. All board assemblies are coated with a protective lacquer.

The thermal concept allows operation at full load up to an ambient temperature of 60 °C in free air without forced cooling. A rugged DIN snap-fit device allows easy and reliable fixing onto the various 35 mm DIN-rail models. The converters are fitted with cage clamp terminals easily accessible from the front. System connectors with screw terminals for use with pre-assembled harnesses, external adjustment of the output voltage, as well as various auxiliary functions are available as options.

Model Selection

Table 1: Standard models

Output 1		Output 2		Output Power	Operating Input Voltage	Type Designation	Efficiency	Options ^{3, 5}
$V_{o1\ nom}$ [VDC]	$I_{o1\ nom}$ [A]	$V_{o2\ nom}^1$ [VDC]	$I_{o2\ nom}$ [A]	$P_{o\ nom}$ [W]	$V_{i\ min} - V_{i\ max}$		η_{min}^7 [%]	
24.7	15	-	-	371	85 ² – 264 VAC, 47 – 63 Hz ⁴ , 90 ² – 350 VDC ⁶	LXR1601-6G	87	R D1, D2, D5 M1, M2 F K2 non-G
24.7	20	-	-	494		LXN1601-6G	87	
37.05	10	-	-	371		LXR1701-6G ³	88	
37.05	13.4	-	-	497		LXN1701-6G ³	88	
49.4	7.5	-	-	371		LXR1801-6G	88	
49.4	10	-	-	494		LXN1801-6G	88	
24.7	10	24.7	10	494		LXN2660-6G	87	
37.05	6.7	37.05	6.7	497		LXN2770-6G ³	88	
49.4	5	49.4	5	494		LXN2880-6G	88	

¹ R-input not connected.

² For derating at low input voltage see section *Output Power Derating*.

³ For minimum quantity and lead times contact Bel Power Solutions.

⁴ The converters have been tested up to 440 Hz; for operating frequencies <47 Hz or >63 Hz contact Bel Power Solutions.

⁵ On double-output models the options R, M2, D1, D2, D5 are related to the 2nd output only.

⁶ $V_i \leq 250$ VDC for models with option F

⁷ Min. efficiency at $V_{i\ nom}$, $I_{o\ nom}$, and $T_A = 25$ °C. Typical values are approx. 2% better.

Not for new designs (NFND) or End of Life (EOL).



Table 2: Battery charger models (M1 included)

Output Voltage			Nominal Output Values			Operating Input Voltage $V_{i\ min} - V_{i\ max}$	Type Designation	Efficiency η_{min}^7 [%]	Options ^{3,5}
V_{Bat} [VDC]	$V_{o\ safe}^1$ [VDC]	$V_{o\ max}$ [VDC]	$V_{o\ nom}^5$ [VDC]	$I_{o\ nom}^5$ [A]	$P_{o\ nom}^5$ [W]				
24	25.68 ¹	29.3	27.3	12.6	344	85 ² – 264 VAC, 47 – 63 Hz ⁴ , 90 ² – 350 VDC ⁶	LXR1240-6M1G	87	F K2 non-G
				16.8	458		LXN1240-6M1G	87	
36	38.52 ¹	43.95	40.88	8.4	343		LXR1840-6M1G ³	87	
				11.2	458		LXN1840-6M1G ³	87	
48	51.36 ¹	58.6	54.5	6.3	343		LXR1740-6M1G	87	
				8.4	458		LXN1740-6M1G	87	

¹ Setting voltage (typ.) with open R-input
² For derating at low input voltage see section *Output Power Derating*.
³ For minimum quantity and lead times consult the factory.
⁴ The converters have been tested up to 440 Hz; for operating frequency <47 Hz or >63 Hz contact the factory
⁵ Nominal output figures, calculated with a cell voltage of 2.27 V at 20 °C.
⁶ $V_i \leq 250$ VDC for models with option F.
⁷ Min. efficiency at $V_{i\ nom}$, $V_{o\ nom}$, $I_{o\ nom}$, and $T_A = 25$ °C. Typical values are approx. 2% better.

Not for new designs (NFND) or End of Life (EOL).

Part Number Description

Input voltage range.....	L	_____
Series	X	_____
Nominal output power		
375 W.....	R	_____
500 W.....	N	_____
Number of outputs.....	1, 2	_____
Type specification	000 – 999	_____
Operational ambient temperature range T_A		
–40 to 60 °C	-6	_____
EW or customer-specific	-0, -5	_____
Options		
Output voltage control input ¹	R	_____
Save data signal ¹	D1, D2, D5	_____
Multiple functions via D-SUB connector ¹ . M1, M2		
Built-in second fuse, input diode	F	_____
System connector	K2	_____
RoHS compliant for all six substances ²	G	_____

L X N 2 6 60 -6 D2 F K2 G

¹ Only one of these options is possible.
² Models without the suffix G (non-G option) do not use lead-free solder.

Note: The sequence of options must follow the order above.

Not for new designs (NFND) or End of Life (EOL).

Example: LXN2660-6D2FG: Power factor corrected AC-DC converter, operating input voltage range 85 – 264 VAC, 2 electrically isolated and individually regulated outputs, each providing 24.7 V, 10 A, options D2, F and RoHS-compatible for all 6 substances.

Product Marking

Basic type designation, applicable safety approval and recognition marks, CE mark, warnings, pin designation, Company logo.

Specific type designation, input voltage range, nominal output voltages and currents, degree of protection, batch and serial number, data code including production site, version, date of production.



Asia-Pacific +86 755 298 85888 EMEA +353 61 531 820 North America +1 866 513 2839

powersupport@belf.com
belfuse.com

Functional Description

The X Series converters are primary controlled AC-DC or DC-DC flyback converters with a constant switching frequency of 130 kHz. The power-factor-corrected single-step conversion of the input voltage to a low output voltage results in extremely high efficiency. Depending on the output power, the converters are fitted with three (375 W) or four (500 W) powertrains. Models with four powertrains have one or two outputs. Double-output models exhibit individual control of each output.

The input voltage is fed via fuse, filter, and rectifier to the powertrains with main transformers designed in planar technique. The input filter with very small input capacitance generates virtually no inrush current. An input transient suppressor protects the converter against high voltage peaks and surges. Input over- and undervoltage lockout as well as input current limitation protect the converter from operation outside of its specification. The input voltage waveform is sensed by the primary control logic to allow active power factor correction, forcing the input current to follow the input voltage waveform.

The secondary side of each main transformer supplies via the rectifier diode a large electrolytic output storage capacitor providing for the hold-up time. Double-output models exhibit an individual control logic for each output. The output voltage and the output current are measured and fed back to the primary control logic via an optocoupler. A second control loop monitors the output voltage. It disables the output in the case of a failure in the control logic and limits the output voltage.

Built-in temperature sensors monitor the internal temperature of each powertrain. If the temperature exceeds the limit, the converter reduces the output power continuously to keep the temperature below its limit. A green LED on the front cover confirms the presence of the output voltage(s).

The R input (option R, M1, or M2) allows for external adjustment of the output voltage by means of a resistor or an external voltage source. An external sensor can be connected to the R input and allows for temperature-controlled battery charging; see Accessories.

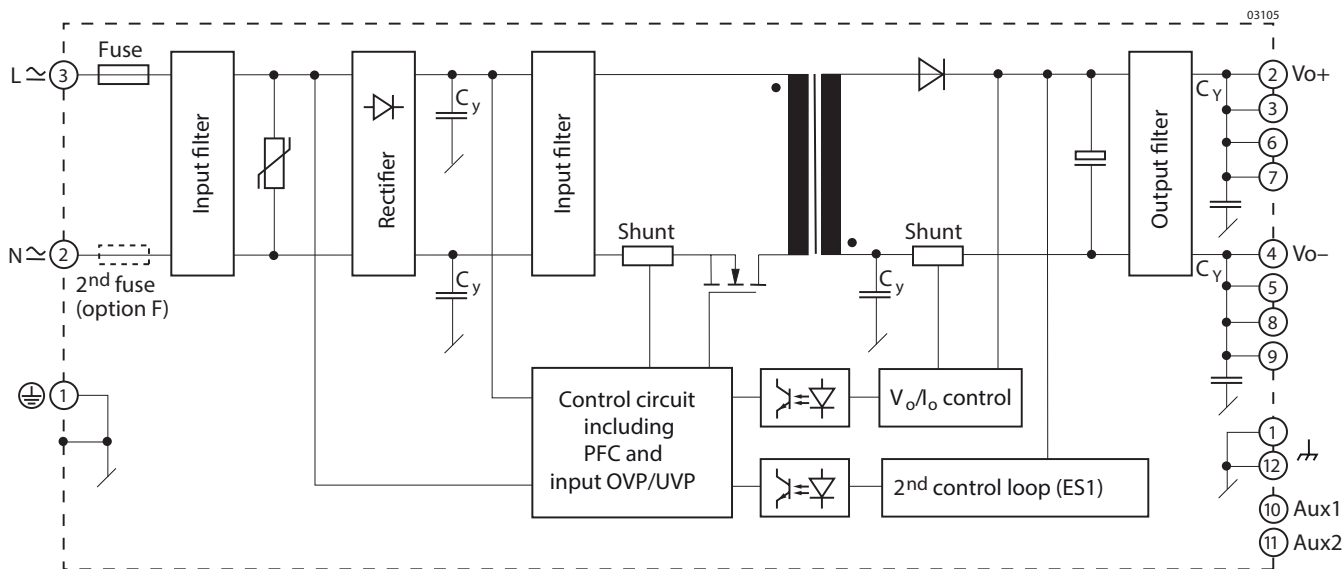

Fig. 1
LXR 375 W single-output converter.

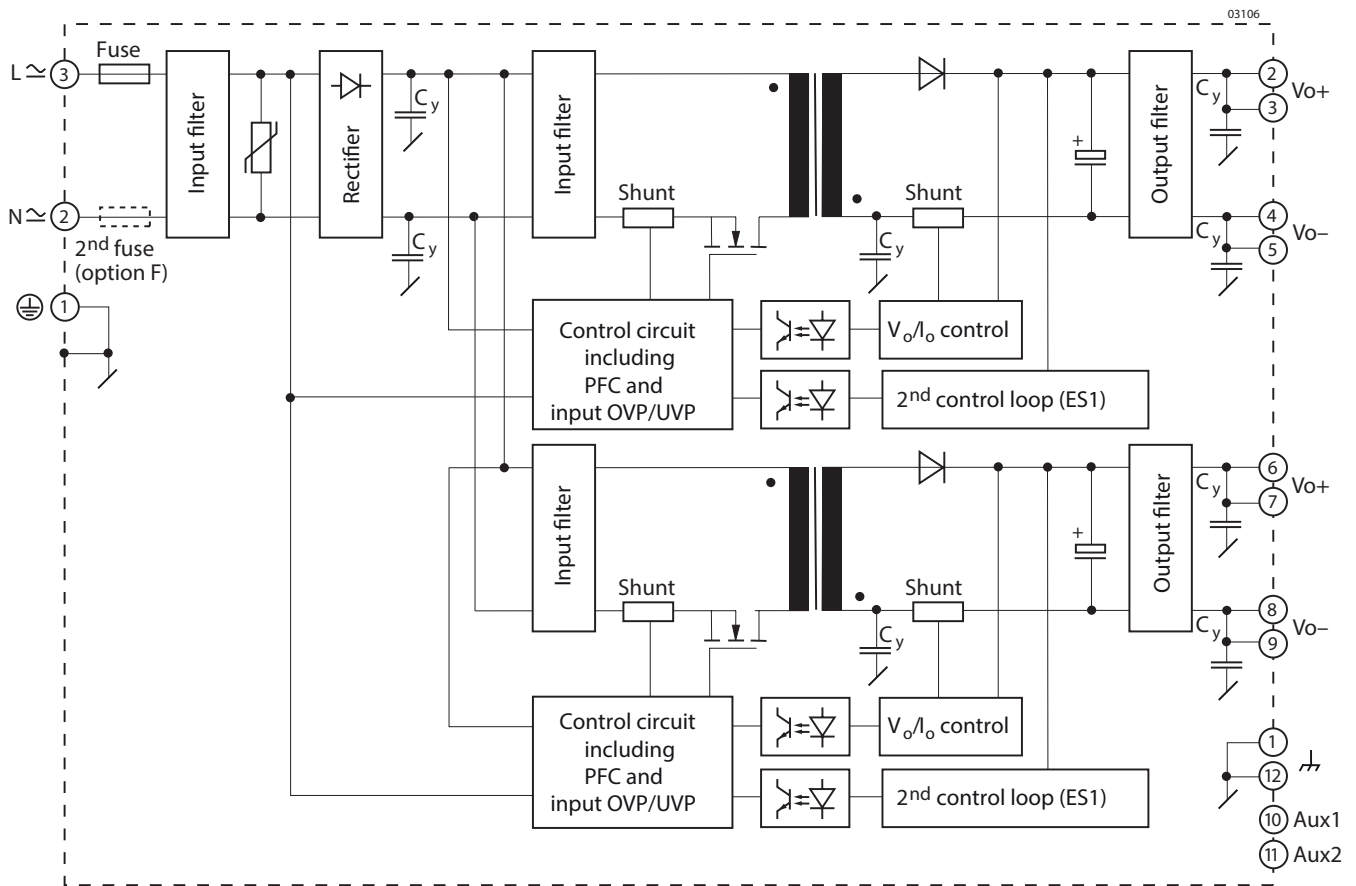

Fig. 2
 LXN 500 W double-output converter
 For the pinout of 500 W single-output models see fig. 1.

Electrical Input Data

General conditions:
 $T_A = 25\text{ °C}$, unless T_C is specified.

Table 3: Input data LW models

Input		Conditions	LXR			LXN			Unit						
			AC Input		DC Input	AC Input		DC Input							
Characteristics			min	typ	max	min	typ	max	min	typ	max				
V_i	Operating input voltage range	$I_o = 0 - I_{o\text{ nom}}$ $T_c - T_{c\text{ max}}$	85 ²		264	90 ²		350 ³	85 ²		264	90 ²		350 ³	V
$V_{i\text{ nom}}$	Rated input voltage range		100	(230)	240		220		100	(230)	240		220		
f_i	Rated input frequency ¹		50 – 60			-			50 – 60			-			Hz
I_i	Input current	$I_{o\text{ nom}}, V_i = V_{i\text{ nom}}$	1.9			1.95			2.6			2.6			A
		$I_{o\text{ nom}}, V_i = V_{i\text{ min}}$	5.2			5.0			7.0			6.6			
P_{i0}	No-load input power	$V_{i\text{ min}} - V_{i\text{ max}}$	3			3			3			3			W
$I_{i\text{ inrush}}$	Inrush current	$V_{i\text{ max}}, t > 0.1\text{ ms}$	5			5			5			5			A
C_i	Input capacitance		5			5			6			6			µF
PF	Power factor	$V_{i\text{ nom}} = 230\text{ V}, I_{o\text{ nom}}$	0.90			-			0.9			-			
$V_{i\text{ RFI}}$	Conducted input RFI	EN 55011/55032	A			A			A			A			
	Radiated input RFI	$V_{i\text{ nom}}, I_{o\text{ nom}}$													
f_{switch}	Switching frequency		130			130			130			130			kHz

¹ For operating frequencies <47 Hz and >63 Hz contact the factory. The converters have been tested up to 440 Hz.

² Output power derating at low input voltage and/or high case temperature T_C ; see *Output Power Derating*.

³ $V_i \leq 250\text{ VDC}$ for models with option F.

Output Power Derating

The output power of LX models must be decreased at low input voltage and/or powertrain temperature above 125 °C.

The powertrain temperature depends on the output power, the input voltage, and the cooling method. At low input voltage the losses increase. At the maximum specified environment temperature T_A free air convection cooling might be insufficient. As a result, the output power has to be reduced according to the tables 4 and 5.

Note: The measurements have been made at the approval tests with free air convection cooling according to UL 60950-1, specified ambient temperature T_A , and with the converter built in a cardboard box according to UL 508 and a specified temperature outside the box T_{out} . The tables give a correlation between T_A or T_{out} and the case temperature T_C (measuring point T_C see *Mechanical Data*). For models not specified, contact the factory.

Table 4: P_o derating according to UL 60950-1 at $T_A = 60\text{ °C}$, or according to UL 508 at $T_{\text{out}} = 50\text{ °C}$

Model	$P_{o\text{ nom}}$ [W]	$T_{C\text{ max}}$ [°C]	Derate below		Derate by
			V_i [VAC]	V_i [VDC]	[W/W]
LXR1601-6	371	89	145	130	- 2.0
LXR1701-6	371	89	145	130	- 2.0
LXR1801-6	371	89	145	130	- 2.0
LXN1601/2660-6	494	89	145	130	- 2.8
LXN1701-6	497	89	145	130	- 2.8
LXN1801/2880-6	494	89	145	130	- 2.8

Table 5: P_o derating according to UL 60950-1 at $T_A = 50\text{ }^\circ\text{C}$, or according to UL 508 at $T_{out} = 40\text{ }^\circ\text{C}$

Model	$P_{o\text{ nom}}$ [W]	$T_{C\text{ max}}$ [$^\circ\text{C}$]	Derate below		Derate by
			V_i [VAC]	V_i [VDC]	[W/V]
LXR1601-6	371	84	125	110	- 2.0
LXR1701-6	371	84	125	110	- 2.0
LXR1801-6	371	84	125	110	- 2.0
LXN1601/2660-6	494	84	125	110	- 2.8
LXN1701-6	497	84	125	110	- 2.8
LXN1801/2880-6	494	84	125	110	- 2.8

Input Fuse and Protection

A slow blow fuse (Schurter T10A, $5 \times 20\text{ mm}$), protected by a sleeve, is connected in the line input. For DC input voltages above 250 V an external DC fuse or a circuit breaker must be installed; observe the *Installation Instructions*.

Converters with option F have 2 fuses, one in each input line. The DC input voltage for all converters with option F is limited to 250 V.

A VDR and a symmetrical input filter form an effective protection against input transients.

An under- and overvoltage lockout protects the converter by disabling it below $V_{i\text{ min}}$ and above $V_{i\text{ max}}$.

The built-in bridge rectifier provides reverse polarity protection at the input if operated from DC.

Efficiency

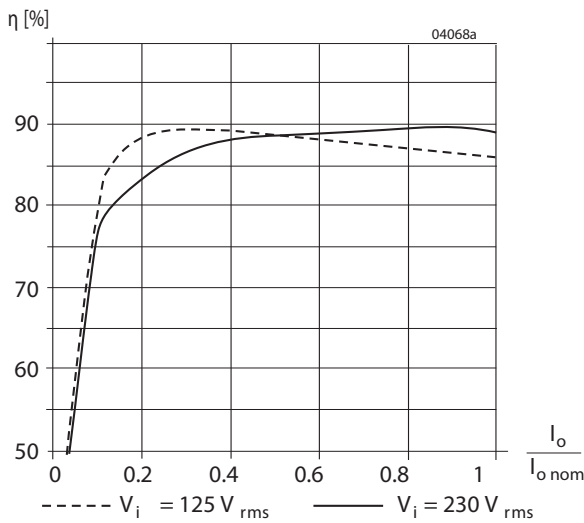

Fig. 3
Efficiency versus load

Power Factor, Harmonics

All converters feature active power factor correction.

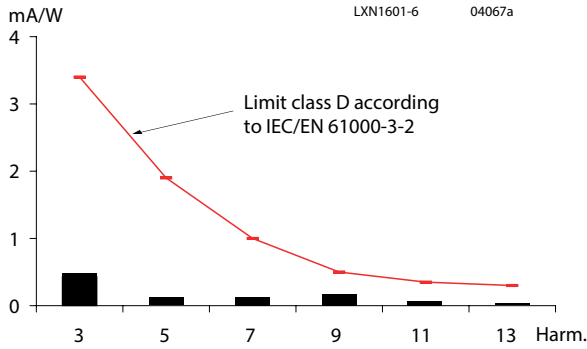

Fig. 4
Harmonic currents at input current, measured at $V_i = 230 \text{ VAC}$, $I_o = I_{o \text{ nom}}$ (LXN1601-6)

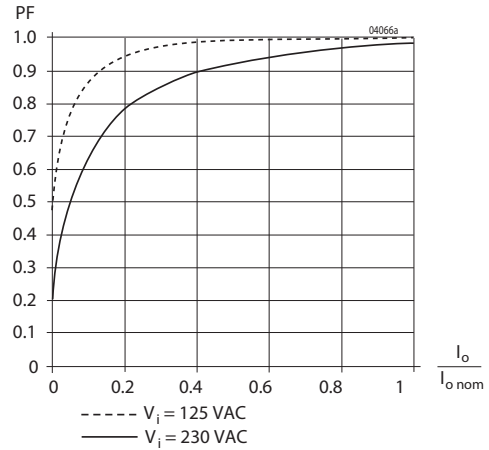

Fig. 5
Power factor versus load

Electrical Output Data

Table 6a: Output data of 375 Watt standard models. General conditions: $T_A = 25 \text{ }^\circ\text{C}$, unless T_A is specified; R input open-circuit

Model			LXR1601			LXR1701			LXR1801			Unit
Characteristics		Conditions	min	typ	max	min	typ	max	min	typ	max	
$V_{o \text{ nom}}$	Output voltage nominal ¹	$V_{i \text{ nom}}, I_{o \text{ nom}}$ *	24.25	24.7	25.2	36.37	37.05	37.8	48.5	49.4	50.4	V
			24.55	24.7	24.85	36.82	37.05	37.28	49.1	49.4	49.7	
$V_{o \text{ worst}}$	Output voltage range of tolerance	$V_{i \text{ min}} - V_{i \text{ max}}, I_o = (0.1 - 1) I_{o \text{ nom}}$	24.0	25.8		36.0		38.7	48.0		51.6	
$V_{o \text{ L}}$	Overvoltage protection		28.5	30		42.75		45	57		60	
$P_{o \text{ nom}}$	Nominal output power	$V_i = 100 \text{ V} - V_{i \text{ max}}$		371			371			371		W
$I_{o \text{ nom}}$	Output current nominal	$V_i = 100 \text{ V} - V_{i \text{ max}}$		15			10			7.5		A
$I_{o \text{ L}}$	Output current limit ³	$V_i = 100 \text{ V} - V_{i \text{ max}}$	15.1		17.2	10.1		11.4	7.57		8.7	
I_{op}	Output current boost ⁴	typ. 1 s		22.5			15			11.3		
	Ripple and noise	$V_i = 230 \text{ VAC}$, $f_i = 50 \text{ Hz}$, $I_{o \text{ nom}}$		100			100			100		mV_{pp}
				1100 ²			1200 ²			1200 ²		
ΔV_{ou}	Static line regulation	100 VAC - $V_{i \text{ max}}, I_{o \text{ nom}}$		± 0.1			± 0.15			± 0.15		V
ΔV_{oi}	Static load regulation (droop)	$V_{i \text{ nom}}, I_o = (0.1 - 1) I_{o \text{ nom}}$		-0.4			-0.6			-0.8		
V_{od}	Dynamic load regulation Voltage deviation Recovery time	$V_{i \text{ nom}}, I_o = (0.5 \leftrightarrow 1) I_{o \text{ nom}}$		± 1.2			± 1.5			± 1.8		
				40			80			80		ms
α_{vo}	Temperature coefficient	$T_{C \text{ min}} - T_{C \text{ max}}$		± 0.02			± 0.02			± 0.02		%/K
t_{or}	Start-up time	$V_i = 0 \rightarrow V_{i \text{ nom}}, I_{o \text{ nom}}$		700			700			700		ms
$t_{oh \text{ min}}$	Hold-up time	$I_{o \text{ nom}}, V_{o \text{ nom}} \rightarrow 0.8 V_{o \text{ nom}}$		15			20			25		

* Standard models with option M or R
¹ Setting voltage with open R-input
² Superimposed low frequency ripple at $2 \cdot f_i$
³ Rectangular current limit characteristic (continuous operation)
⁴ Short-term peak power capability 150% of $P_{o \text{ nom}}$ for approx. 1 s

Table 6b: Output data of 500 Watt single-output standard models. General conditions as per table 6a.

Model		Conditions	LXN1601			LXN1701			LXN1801			Unit
Characteristics	min		typ	max	min	typ	max	min	typ	max		
$V_{o\ nom}$	Output voltage nominal ¹	$V_{i\ nom}, I_{o\ nom}$ *	24.25	24.7	25.2	36.37	37.05	37.8	48.5	49.4	50.4	V
			24.55	24.7	24.85	36.82	37.05	37.28	49.1	49.4	49.7	
$V_{o\ worst}$	Output voltage range of tolerance	$V_{i\ min} - V_{i\ max}, I_{o\ nom}$ $I_{o\ nom} = (0.1 - 1) I_{o\ nom}$	24.0		25.8	36.0		38.7	48.0		51.6	
$V_{o\ L}$	Overvoltage protection		28.5		30	42.75		45	57		60	
$P_{o\ nom}$	Nominal output power	$V_i = 100\ V - V_{i\ max}$	494			497			494			W
$I_{o\ nom}$	Output current nominal	$V_i = 100\ V - V_{i\ max}$	20			13.4			10			A
$I_{o\ L}$	Output current limit ³	$V_i = 100\ V - V_{i\ max}$	20.1			13.5			10.1			
I_{op}	Output current boost ⁴	typ. 1 s	30			20			15			
	Ripple and noise	$V_i = 230\ VAC,$ $f_i = 50\ Hz, I_{o\ nom}$ ²	100			100			100			mV _{pp}
			1100 ²			1200 ²			1200 ²			
$\Delta V_{o\ u}$	Static line regulation	100 VAC - $V_{i\ max}, I_{o\ nom}$	±0.1			±0.15			±0.15			V
$\Delta V_{o\ l}$	Static load regulation (droop)	$V_{i\ nom}, I_{o\ nom} = (0.1 - 1) I_{o\ nom}$	-0.4			-0.6			-0.8			
V_{od}	Dynamic load regulation Voltage deviation Recovery time	$V_{i\ nom}, I_{o\ nom} = (0.5 \leftrightarrow 1) I_{o\ nom}$	±1.2			±1.5			±1.8			ms
			40			80			80			
α_{vo}	Temperature coefficient	$T_{C\ min} - T_{C\ max}$	±0.02			±0.02			±0.02			%/K
t_{or}	Start-up time	$V_i = 0 \rightarrow V_{i\ nom}, I_{o\ nom}$	700			700			700			ms
$t_{oh\ min}$	Hold-up time	$I_{o\ nom}, V_{o\ nom} \rightarrow 0.8 V_{o\ nom}$	15			20			25			

Table 6c: Output data of 500 Watt double-output models. General conditions as per table 6a.

Model		Conditions	LXN2660			LXN2770			LXN2880			Unit
Characteristics	min		typ	max	min	typ	max	min	typ	max		
$V_{o\ nom}$	Output voltage nominal ¹	$V_{i\ nom}, I_{o\ nom}$ *	24.25	24.7	25.2	36.37	37.05	37.8	48.5	49.4	50.4	V
			24.55	24.7	24.85	36.82	37.05	37.28	49.1	49.4	49.7	
$V_{o\ worst}$	Output voltage range of tolerance	$V_{i\ min} - V_{i\ max}, I_{o\ nom}$ $I_{o\ nom} = (0.1 - 1) I_{o\ nom}$	24.0		25.8	36.0		38.7	48.0		51.6	
$V_{o\ L}$	Overvoltage protection		28.5		30	42.75		45	57		60	
$P_{o\ nom}$	Nominal output power	$V_i = 100\ V - V_{i\ max}$	494			497			494			W
$I_{o\ nom}$	Output current nominal	$V_i = 100\ V - V_{i\ max}$	2 x 10			2 x 6.7			2 x 5			A
$I_{o\ L}$	Output current limit ³	$V_i = 100\ V - V_{i\ max}$	10.1			6.8			5.1			
I_{op}	Output current boost ⁴	typ. 1 s	2 x 15			2 x 10			2 x 7.5			
	Ripple and noise	$V_i = 230\ VAC,$ $f_i = 50\ Hz, I_{o\ nom}$ ²	100			100			100			mV _{pp}
			1100 ²			1200 ²			1200 ²			
$\Delta V_{o\ u}$	Static line regulation	100 VAC - $V_{i\ max}, I_{o\ nom}$	±0.1			±0.15			±0.15			V
$\Delta V_{o\ l}$	Static load regulation (droop)	$V_{i\ nom}, I_{o\ nom} = (0.1 - 1) I_{o\ nom}$	-0.4			-0.6			-0.8			
V_{od}	Dynamic load regulation Voltage deviation Recovery time	$V_{i\ nom}, I_{o\ nom} = (0.5 \leftrightarrow 1) I_{o\ nom}$	±1.2			±1.5			±1.8			ms
			40			80			80			
α_{vo}	Temperature coefficient	$T_{C\ min} - T_{C\ max}$	±0.02			±0.02			±0.02			%/K
t_{or}	Start-up time	$V_i = 0 \rightarrow V_{i\ nom}, I_{o\ nom}$	700			700			700			ms
$t_{oh\ min}$	Hold-up time	$I_{o\ nom}, V_{o\ nom} \rightarrow 0.8 V_{o\ nom}$	15			20			25			

* Standard models with option M or R

¹ Setting voltage with open R-input

² Superimposed low frequency ripple at $2 \cdot f_i$

³ Rectangular current limit characteristic (continuous operation)

⁴ Short-term peak power capability 150% of $P_{o\ nom}$ for approx. 1 s

Table 7a: Output data of 350 Watt battery charger models.

 General conditions: $T_A = 25\text{ }^\circ\text{C}$, unless T_A is specified; R input left open-circuit, unless otherwise specified

Model		LXR1240-6M1			LXR1840-6M1			LXR1740-6M1			Unit		
Characteristics		Conditions		min	typ	max	min	typ	max	min	typ	max	
$V_{o\ safe}$	Output setting voltage ¹	$V_{i\ nom}, I_{o\ nom}$		24.5	25.68	26.3	36.75	38.52	39.45	49	51.36	52.6	V
V_{Bat}	Output voltage (max) controlled by R input	$V_{i\ min} - V_{i\ max}, I_o = (0.1 - 1) I_{o\ nom}$		29.3			43.95			58.6			
V_{oL}	Overvoltage protection			30.9	32.5		46.35		48.75	61.8		65	
$P_{o\ nom}$	Output power nominal	$V_i = 100\text{ V} - V_{i\ max}$		344			343			343			W
$I_{o\ nom}$	Output current nominal	$V_i = 100\text{ V} - V_{i\ max}$		12.6			8.4			6.3			A
I_{oL}	Output current limit	$V_i = 100\text{ V} - V_{i\ max}$		12.7	15		8.5		10	6.36		7.5	
I_{op}	Output current boost ³	typ. 1 s		18.9			12.6			9.5			
v_o	Ripple & noise	$V_i = 230\text{ VAC}, f_i = 50\text{ Hz}, I_{o\ nom}^2$		100			100			100			mV _{pp}
				1100 ²			1200 ²			1200 ²			
ΔV_{ou}	Static line regulation	$100\text{ V} - V_{i\ max}, I_{o\ nom}$		± 0.1			± 0.15			± 0.15			V
ΔV_{ol}	Static load regulation (droop)	$V_{i\ nom}, I_o = (0.1 - 1) I_{o\ nom}$		-0.4			-0.6			-0.8			
V_{od}	Dynamic load regulation Voltage deviation	$V_{i\ nom}, I_o = (0.5 \leftrightarrow 1) I_{o\ nom}$		± 1.2			± 1.6			± 1.9			
	Recovery time			40			80			80			ms
α_{vo}	Temperature coefficient	$T_{C\ min} - T_{C\ max}$		± 0.02			± 0.02			± 0.02			%/K
t_{or}	Start-up time	$V_i = 0 \rightarrow V_{i\ nom}, I_{o\ nom}$		700			700			700			ms

Table 7b: Output data of 500 Watt battery charger models. General conditions as per table 7a

Model		LXN1240-6M1			LXN1840-6M1			LXN1740-6M1			Unit		
Characteristics		Conditions		min	typ	max	min	typ	max	min	typ	max	
$V_{o\ safe}$	Output setting voltage ¹	$V_{i\ nom}, I_{o\ nom}$		24.5	25.68	26.3	36.75	38.52	39.45	49	51.36	52.6	V
V_{Bat}	Output voltage (max) controlled by R input	$V_{i\ min} - V_{i\ max}, I_o = (0.1 - 1) I_{o\ nom}$		29.3			43.95			58.6			
V_{oL}	Overvoltage protection			30.9	32.5		46.35		48.75	61.8		65	
$P_{o\ nom}$	Output power nominal	$V_i = 100\text{ V} - V_{i\ max}$		458			458			458			W
$I_{o\ nom}$	Output current nominal	$V_i = 100\text{ V} - V_{i\ max}$		16.8			11.2			8.4			A
I_{oL}	Output current limit	$V_i = 100\text{ V} - V_{i\ max}$		16.9	20		11.3		13.3	8.5		10	
I_{op}	Output current boost ³	typ. 1 s		25.2			16.8			12.6			
v_o	Ripple & noise	$V_i = 230\text{ VAC}, f_i = 50\text{ Hz}, I_{o\ nom}^2$		100			100			100			mV _{pp}
				1100 ²			1200 ²			1200 ²			
ΔV_{ou}	Static line regulation	$100\text{ V} - V_{i\ max}, I_{o\ nom}$		± 0.1			± 0.15			± 0.15			V
ΔV_{ol}	Static load regulation (droop)	$V_{i\ nom}, I_o = (0.1 - 1) I_{o\ nom}$		-0.4			-0.6			-0.8			
V_{od}	Dynamic load regulation Voltage deviation	$V_{i\ nom}, I_o = (0.5 \leftrightarrow 1) I_{o\ nom}$		± 1.2			± 1.6			± 1.9			
	Recovery time			40			80			80			ms
α_{vo}	Temperature coefficient	$T_{C\ min} - T_{C\ max}$		± 0.02			± 0.02			± 0.02			%/K
t_{or}	Start-up time	$V_i = 0 \rightarrow V_{i\ nom}, I_{o\ nom}$		700			700			700			ms

¹ Setting voltage with open R-input = $V_{o\ safe}$
² Superimposed low frequency ripple at $2 \cdot f_i$
³ Rectangular current limit characteristic (continuous operation)

⁴ Short-term peak power capability 150% of $P_{o\ nom}$ for approx. 1 s

Parallel Operation

Double-output models exhibit an independent control logic each. Both outputs can be connected in parallel, provided that the options S (included in M1) and R are not used, since they influence only the 2nd output. The two pairs of powertrains share the current due to their output voltage droop characteristic.

Up to 3 converters with the same output voltage may be operated in parallel. It is possible to parallel W Series with X Series converters.

Reasonable current sharing is achieved by the droop characteristic. Correct mode of operation is highly dependent upon the wiring of the converters and the impedance of these wires. Use wires with equal length and equal cross sections of min. 1.5 mm². The best results for parallel operation can be achieved with the wiring shown in fig. 6.

Parallel operation of single-output models using option R (output voltage adjust) is possible, but not recommended. Refer to fig. 6; the connections between the pins 8 and 9 (both Vo-) should be as short as possible.

Note: Parallel operation is not possible, if a temperature sensor is connected, as the sensor eliminates the output voltage droop.

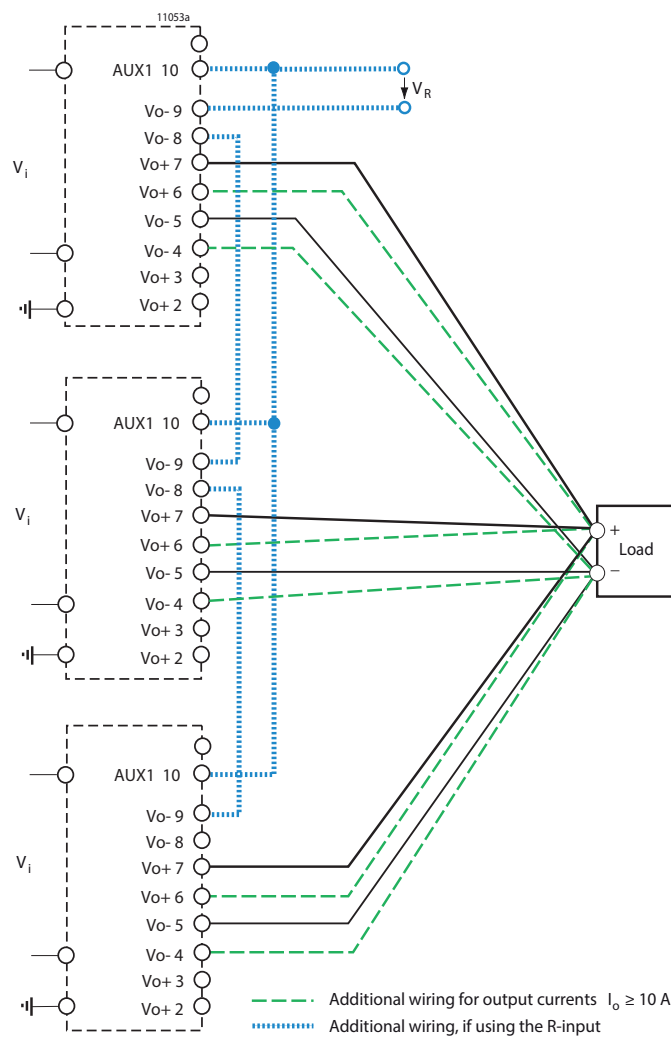

Fig. 6
Wiring for single-output converters connected in parallel. Additional wiring for higher output currents and with the use of option R is shown.

Series Connection

Series connection of several outputs up to 150 V is possible. The output is not ES1, when the max. output voltage exceeds 60 V.

Output Characteristic and Protection

The output characteristic, individual for each group of powertrains, is rectangular with a droop to ease parallel operation; see fig. 7. However, a 50% higher output current is possible for a short time, such allowing start-up of loads or charging of capacitors; see fig. 8. Each output is independently protected against internal overvoltage by means of a second control loop. When the output voltage exceeds V_{oL} , the respective output is disabled.

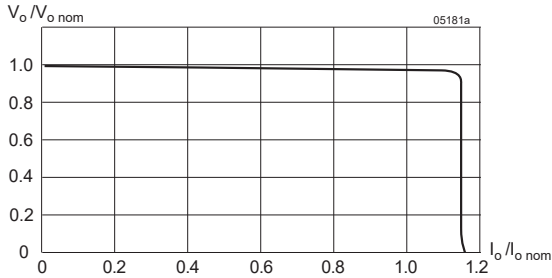

Fig. 7
 V_o versus I_o (single-output model, typical values).

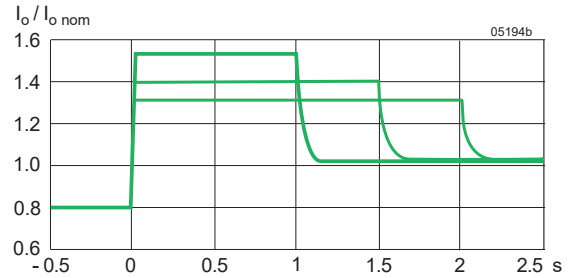

Fig. 8
Short term peak power characteristic: overcurrent versus time (typical values).

Overtemperature Protection

Each powertrain is independently protected against overtemperature by a built-in temperature sensor. When a certain temperature is reached, the concerned powertrain reduces its output power continuously.

Thermal Considerations

The thermal conditions are influenced by input voltage, output current, airflow, and temperature of surrounding components. $T_{A,max}$ is therefore, contrary to $T_{C,max}$, an indicative value only.

Caution: The installer must ensure that under all operating conditions T_C remains within the limits stated in the table *Temperature specifications*.

Note: Sufficient forced cooling allows T_A to be higher than $T_{A,max}$ provided that $T_{C,max}$ is not exceeded. It is recommended that continuous operation under worst case conditions of the following 3 parameters be avoided: Minimum input voltage, maximum output power, and maximum temperature.

Battery Charging and Temperature Sensor

The battery charger models exhibit the option M1 and have been designed to charge lead-acid batteries. The R-input allows for connecting a battery-specific temperature sensor, which provides temperature-controlled adjust of the trickle charge voltage. This optimizes charging as well as battery life time. Depending upon the cell voltage and the temperature coefficient of the battery, different sensor types are available; see *Accessories*.

Note: Parallel operation is not possible, if the temperature sensor is connected to the paralleled outputs Vo+, as the sensor eliminates the output voltage droop.

However, it is possible to insert bleeding resistors in the Vo+ output lines of each converter in order to create a droop of approx. 0.6 V @ $I_{o,nom}$ for 24 V outputs (1.2 V @ $I_{o,nom}$ for 48 V outputs), but this creates considerable power losses.

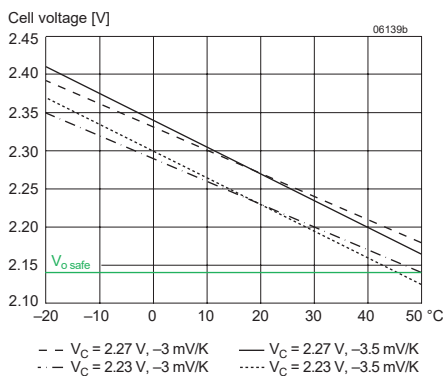

Fig. 9
Trickle charge voltage versus temperature for different temperature coefficients ($V_{o,safe}$ with disconnected sensor)

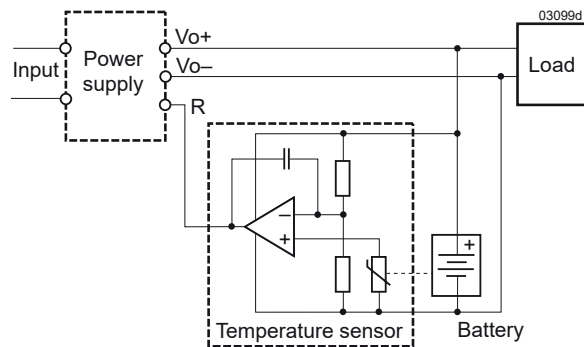

Fig. 10
Schematic circuit diagram of a system with battery backup and temperature-controlled charging.

Electromagnetic Compatibility (EMC)

Electromagnetic Immunity

The X Series has been successfully tested to the following specifications:

Table 8: Electromagnetic immunity (type tests)

Phenomenon	Standard	Level	Coupling mode ¹	Value applied	Waveform	Source imped.	Test procedure	In oper.	Perf. crit. ²
Electrostatic discharge (to case)	IEC/EN 61000-4-2	4 ³	contact discharge	8000 V _p	1/50 ns	330 Ω 150 pF	10 positive and 10 negative discharges	yes	A
			air discharge	15000 V _p					
Electromagnetic field RF	IEC/EN 61000-4-3	x ⁴	antenna	20 V/m	AM 80% / 1 kHz	N/A	80 – 800 MHz	yes	A
		5 ⁵	antenna	20 V/m					
			10 V/m						
			5 V/m						
3 V/m									
Electrical fast transients/burst	IEC/EN 61000-4-4	3 ⁶	capacitive, o/c	±2000 V _p	bursts of 5/50 ns 2.5/5 kHz over 15 ms; burst period: 300 ms	50 Ω	60 s positive 60 s negative transients per coupling mode	yes	A
		4	±i/c, +i/-i direct	±4000 V _p					
Surges	IEC/EN 61000-4-5	3 ⁷	+i/c, -i/c	±2000 V _p	1.2 / 50 μs	12 Ω	5 pos. & 5 neg. surges per coupling mode	yes	B
		2 ⁷	+i/-i	±1000 V _p	1.2 / 50 μs				
Conducted disturbances	IEC/EN 61000-4-6	3 ⁸	i, o, signal wires	10 VAC	AM 80% / 1 kHz (140 dBμV)	150 Ω	0.15 – 80 MHz	yes	A
Power frequency magnetic field	IEC/EN 61000-4-8	9	–	100 A/m	50 and 60 Hz	–	x, y, and z axis	yes	A

¹ i = input, o = output, c = case.

² A = Normal operation, no deviation from specs; B = Normal operation, temporary loss of function or deviation from specs. possible

³ Exceeds EN 50121-3-2:2016 table 5.3 and EN 50121-4:2016 table 2.4.

⁴ Corresponds to EN 50121-3-2:2016 table 5.1 and EN 50121-4:2016 table 2.1.

⁵ Complies with EN 50121-3-2:2016 table 5.2 and EN 50121-4:2016 table 2.2.

⁶ Complies with EN 50121-3-2:2016 table 3.2 and EN 50121-4:2016 table 3.2.

⁷ Complies with EN 50121-3-2:2016 table 3.3 and EN 50121-4:2016 table 3.3.

⁸ Corresponds to EN 50121-3-2:2016 table 3.1 and EN 50121-4:2016 table 3.1 (radio frequency common mode).

⁹ Complies with EN 50121-4:2016 table 2.3 (Power frequency magnetic field, AC input).

Emissions

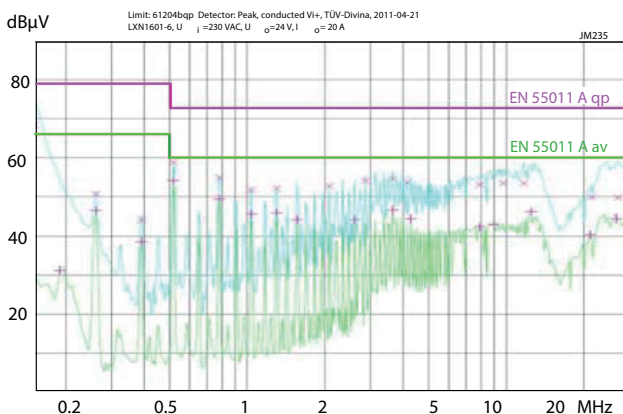

Fig. 11
Conducted emissions for LXN1601-6:
Typical disturbances, peak and quasi-peak at input L as per EN 55011, measured at V_i = 230 VAC and I_{o,nom}.

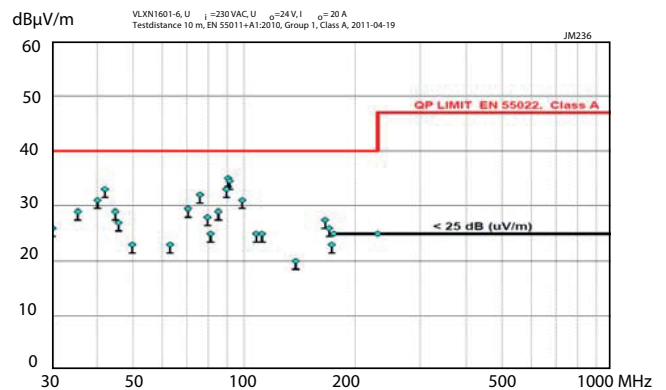

Fig. 12
Radiated emissions for LXN1601-6:
Typical electromagnetic field strength (quasi-peak) in 10 m distance as per EN 55011, V_{i,nom} and I_{o,nom}. Ferrite KEKitagawa TRCN-28-16-20 with 2 turns on input cable.

Table 9: Harmonics and flicker

Phenomenon	Standards	Conditions	Results
Harmonics	EN 61000-3-2:2006	$V_i = 230 \text{ V}, V_{o, \text{nom}}, I_{o, \text{nom}}$	Class A, D
Voltage fluctuation and flicker	EN 61000-3-3 + A2:2005	$V_i = 230 \text{ V}, V_{o, \text{nom}}, I_{o, \text{nom}}$	Complied

Immunity to Environmental Conditions

Table 10: Mechanical stress and climatic

Test method	Standard	Test Conditions	Status
Cab	Damp heat steady state IEC/EN 60068-2-78 MIL-STD-810D section 507.2	Temperature: 40 ±2 °C	Converter not operating
		Relative humidity: 93 ±2/-3 %	
		Duration: 56 days	
Kb	Salt mist, cyclic (sodium chloride NaCl solution) IEC/EN 60068-2-52	Concentration: 5% (30 °C)	Converter not operating
		Duration: 2 h per cycle	
		Conditions: 40°C, 93% rel. humidity	
		Storage Duration: 3 cycles of 22 h	
E b	Bump (half-sinusoidal) IEC/EN 60068-2-29 MIL-STD-810D sect. 516.3	Acceleration amplitude: 25 g _n = 245 m/s ²	Converter not operating, wall mounted ¹
		Bump duration: 11 ms	
		6000 bumps: 1000 in each direction	Converter not operating, on DIN-rail ²
		Acceleration amplitude: 10 g _n = 98.1 m/s ²	
		Bump duration: 11 ms	
		6000 bumps: 1000 in each direction	
Fc	Vibration (sinusoidal) IEC/EN 60068-2-6 MIL-STD-810D sect. 514.3	Acceleration amplitude: 0.35 mm (10 – 60 Hz)	Converter operating, wall mounted ¹
		Frequency (1 Oct/min): 5 g _n = 49 m/s ² (60 – 2000 Hz)	
		Test duration: 7.5 h (2.5 h each axis)	Converter operating, on DIN-rail ²
		Acceleration amplitude: 0.25 mm (10 – 60 Hz)	
		Frequency (1 Oct/min): 2 g _n = 19 m/s ² (60 – 2000 Hz)	
		Test duration: 7.5 h (2.5 h each axis)	
Ea	Shock (half-sinusoidal) IEC/EN 60068-2-27 MIL-STD-810D sect. 516.3	Acceleration amplitude: 50 g _n = 490 m/s ²	Converter not operating, wall mounted ¹
		Bump duration: 11 ms	
		Number of bumps: 18 (3 in each direction)	
Fh	Random vibration broad band, digital control & guidance IEC/EN 60068-2-64	Acceleration spectral density: 0.05 g _n ² / Hz	Converter operating, wall mounted ¹
		Frequency band: 20 – 500 Hz	
		Acceleration magnitude: 4.9 g _{n,rms}	
		Test duration: 3 h (1 h each axis)	
Fda	Random vibration wide band, high reproducibility IEC/EN 60068-2-35	Acceleration spectral density: 0.01 g _n ² / Hz	Converter operating, mounted on DIN-rail ²
		Frequency band: 20 – 500 Hz	
		Acceleration magnitude: 2.2 g _{n,rms}	
		Test duration: 1.5 h (0.5 h each axis)	

¹ Wall-mounted with brackets UMB-W [HZZ00618]; see *Accessories*

² Fastened on a DIN-rail with 2 additional DIN-rail fixing brackets DMB-EWG; see *Accessories*. This also covers wall-mounting with brackets, because wall mounting performs better in vibration test.

Temperatures

Table 11: Temperature specifications, valid for an air pressure of 800 - 1200 hPa (800 - 1200 mbar)

Model			Standard models -6		Unit
Characteristics		Conditions	min	max	
T_A	Ambient temperature	Converter operating ¹	-40	60	° C
T_C	Case temperature ²		-40	90 ²	
T_S	Storage temperature	Non operational	-40	85	

¹ See *Thermal Considerations*

² See table 5 *P_o derating*

Failure Rates

Table 12: MTBF

Values at specified case temperature	Module types	Ground benign 40 °C	Ground fixed		Ground mobile 50 °C	Unit
			40 °C	70 °C		
MTBF ¹	LXN1801-6	400 000	110 000	50 000	40 000	h

¹ Calculated in accordance with MIL-HDBK-217E, notice 2.

Mechanical Data

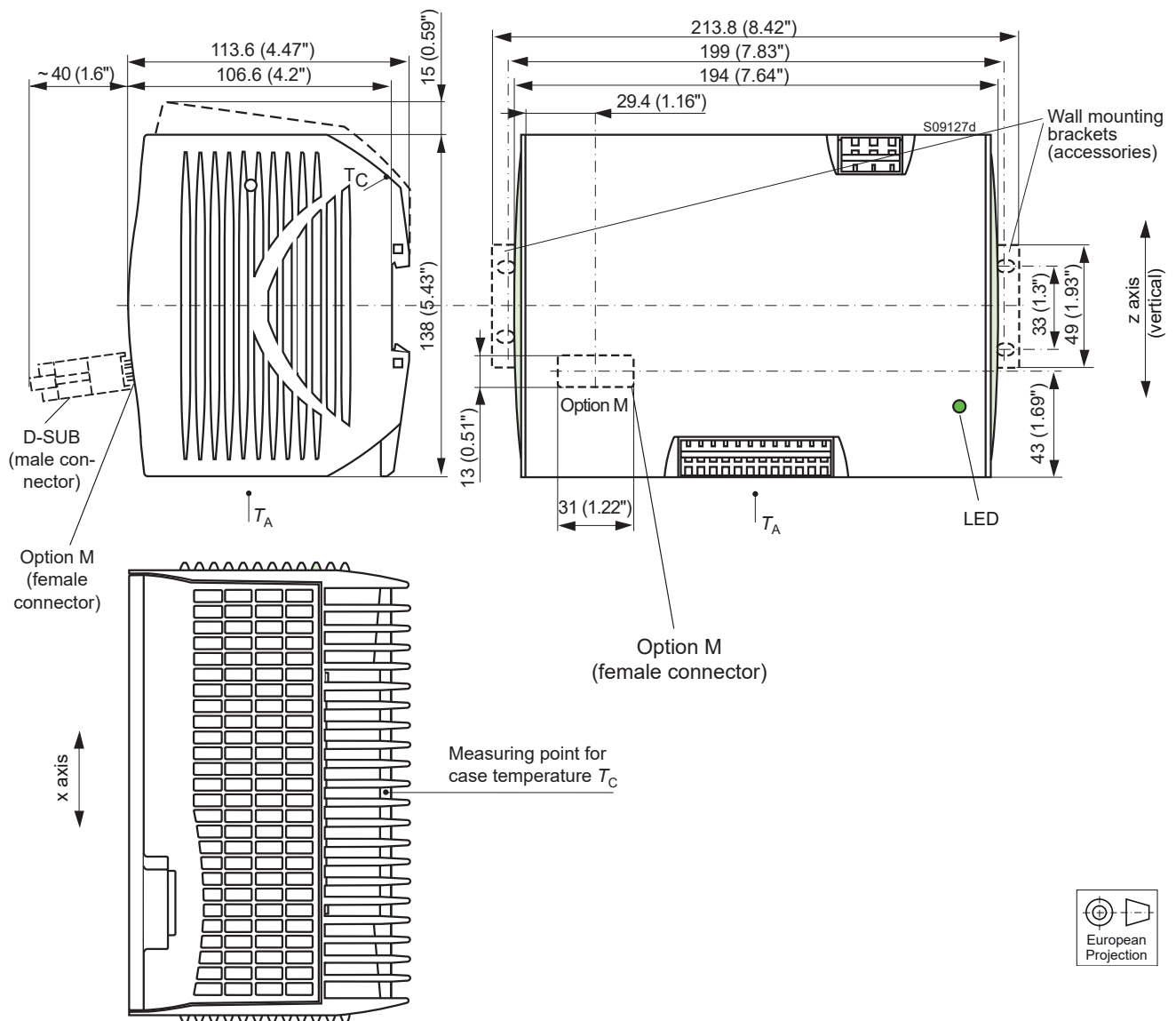

Fig. 13
 Case X01
 LXR: weight approx. 2600 g
 LXN: weight approx. 2800 g
 Case designed by ATP, Munich.

Safety and Installation Instructions

Terminal Allocation

The terminal allocation tables define the electrical potential of the converters.

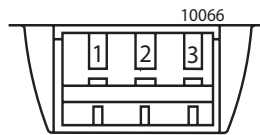

Fig. 14a
View of the input terminals (cage clamp style)

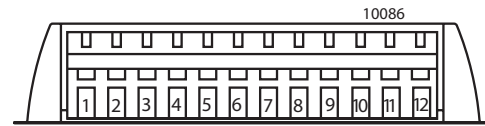

Fig. 14b
View of the output terminals (cage clamp style)

Table 13a: Input terminals of LX models

Pin no.	Pin designation	Electrical determination
1	⊕	Protective earth PE
2	N≈	Input neutral, DC negative
3	L≈	Input phase, DC positive

Table 13b: Terminal allocation output side

Pin no.	Pin des.	Single output	Double output
1	⏏	Functional earth to load	Functional earth to load
2	+	Output positive	Output 1 positive
3	+	Output positive	Output 1 positive
4	-	Output negative	Output 1 negative
5	-	Output negative	Output 1 negative
6	+	Output positive	Output 2 positive
7	+	Output positive	Output 2 positive
8	-	Output negative	Output 2 negative
9	-	Output negative	Output 2 negative
10	AUX1	Option 1	Option 1
11	AUX2	Option 2	Option 2
12	⏏	Functional earth to load	Functional earth to load

Installation Instructions

The X Series converters are components, intended exclusively for inclusion within other equipment by professional installers. The installation must strictly follow the national safety regulations in compliance with the enclosure, mounting, creepage, clearance, casualty, markings and segregation requirements of the end-use application.

DIN-rail mounting is possible with the built-in snap-fit device on a DIN-rail. This fulfills the mechanical transport requirements as per ETSI 300019-1-2, class 2 (vertical).

To fulfill the requirements of IEC 721-3-2, class 2.1 (vertical), 2 additional fixing brackets HZZ00624-G (see *Accessories*) must be fitted on the bottom side of the DIN-rail. For heavy duty applications, we recommend installing all 4 fixing brackets HZZ00624-G.

Chassis or wall mounting is possible with the wall-mounting brackets HZZ00618 (see *Accessories*). This complies with IEC 721-3-2, class 2.2 (vertical and horizontal).

Caution: Install the converters vertically, and make sure that there is sufficient airflow available for convection cooling. The minimum space to the next device should be: top/bottom: 30 mm, left/right: 20 mm.

The converters of the X Series are class I equipment: Input terminal 1 (⊕) and the output terminals 1 and 12 (⏏) are reliably connected to the case. For safety reasons it is essential to connect the input terminal 1 (⊕) with protective earth. Output terminals 1 and 12 can be used to connect the output voltage(s) or the load to functional earth.

The phase input (L) is internally fused; see *Input Fuse and Protection*. This fuse is designed to break an overcurrent in case of a malfunction of the converter and is not customer-accessible.

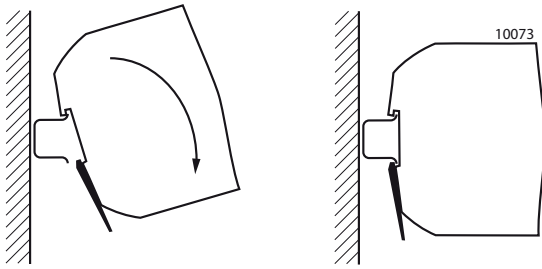

Fig. 15a
Snap-fit mounting to DIN-Rail.

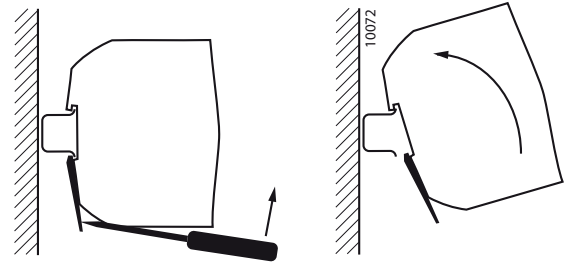

Fig. 15b
Dismounting from DIN-rail. Use proper tool
(min. 3 mm screwdriver) and adequate force.

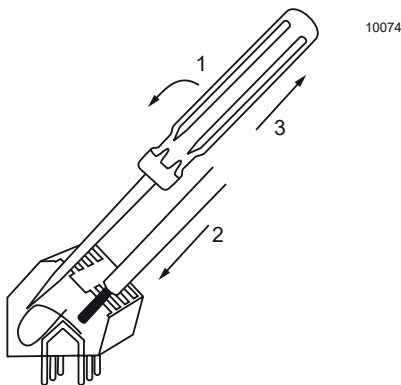

Fig. 16
Cage clamp terminals. Use 0.5 to 2.5 mm² (AWG 20 to 12) solid or stranded wires depending on local requirements.

External fuses in the wiring to one or both input line (L_~ and/or N_~) may be necessary to ensure compliance with local requirements. A built-in second fuse in the neutral path is available as option F.

A second fuse in the wiring to the neutral terminal N or option F is needed if:

- Local requirements demand an individual fuse in each source line
- Neutral and earth impedance is high or undefined
- Phase and neutral of the mains are not defined or cannot be assigned to the corresponding terminals (L_~ to phase and N_~ to neutral).

Models with option F: Caution! Double-pole/neutral fusing.

If the converter operates at source voltages above 250 VDC, an external DC fuse or a circuit breaker at system level should be installed in the phase input line L_~.

Caution:

- Installation must strictly follow the national safety regulations.
- Do not open this apparatus!

Protection Degree and Cleaning Agents

The protection degree of the converters is IP 20. Protective covers over input and output terminals are available on request; see *Accessories*.

Any penetration of liquid or foreign solid objects has to be prevented, since the converters are not hermetically sealed.

Standards and Approvals

The X Series converters were approved according to UL/CSA 60950-1 and CE declaration according IEC/EN 62368-1.

The converters have been designed in accordance with said standards for:

- Class I equipment
- Power-supply for building-in, vertical mounting on 35 mm DIN-rail or on a wall
- Overvoltage category II (III for 110 VAC supply)
- Basic insulation between input and case, based on 250 VAC
- Double or reinforced insulation between input and output, based on 250 VAC and 350 VDC
- Functional insulation between outputs and case
- Functional insulation between outputs
- Pollution degree 2 environment

The converters are subject to manufacturing surveillance in accordance with the ISO 9001:2015.

See also the Declaration of Conformity (last page).

Railway Applications

The X Series converters have been designed by observing the railway standards EN 50155 and EN 50121. All boards are coated with a protective lacquer.

Isolation

The electric strength test is performed in the factory as routine test in accordance with EN 62911 and IEC/EN 62368-1 and should not be repeated in the field. The Company will not honor warranty claims resulting from incorrectly executed electric strength field tests.

Table 14: Isolation

Characteristics		Input to Case and Output(s)	Output(s) to Case	Output 1 to Output 2 and AUX	Unit
Electric strength test	Factory test ≥ 1 s	2.8 ¹	1.4	0.5	kVDC
	AC test voltage equivalent to factory test	2.0	1.0	0.35	kVAC
Insulation resistance		$>300^2$	$>300^2$	>100	M Ω

¹ Subassemblies are pretested with 4.2 kVDC.

² Tested at 500 VDC.

Leakage Currents

Leakage currents flow due to internal leakage capacitance (mainly the Y-capacitors). The current values are proportional to the voltage V_i and the frequency f_i of the supply (mains). The leakage currents are specified at maximum operating input voltage, provided that phase, neutral, and protective earth are correctly connected as required for class I equipment.

Caution: Leakage current may exceed 5 mA, if $f_i > 63$ Hz.

Safety of Operator-Accessible Output Circuits

If the output circuit of a converter is operator-accessible, it shall be a ES1 circuit according to the safety standards IEC/EN 62368-1 3rd edition.

The converters have ES1 output circuits up to an output voltage of 57.5 V. However, if the isolated outputs are connected to another voltage source or connected in series with a total of >57.5 V, the outputs are hazardous.

LED Indicator

A green LED is activated, when the output voltage V_o is within the normal operating tolerance band.

Note: This LED is also activated, when the converter is not powered by the input, but a loaded battery is connected to the output.

Description of Options

Single options **D1**, **D2**, **D5**, **R** are available on the AUX1 terminal (10), referenced to Vo- or Vo2-.

Option **M1** and **M2** designate a combination of several options accessible via a D-SUB connector or in some cases on the AUX1 and AUX2 terminals. Option M1 includes the function SD.

Note: In double-output models, the options D1, D5, R, and SD concern only output 2 connected to terminals 6, 7, 8, and 9.

Single Options Using the AUX1 Pin

The connection is shown in the figure below. For the description refer to *Adjustment of Vo or Vo2* (next section).

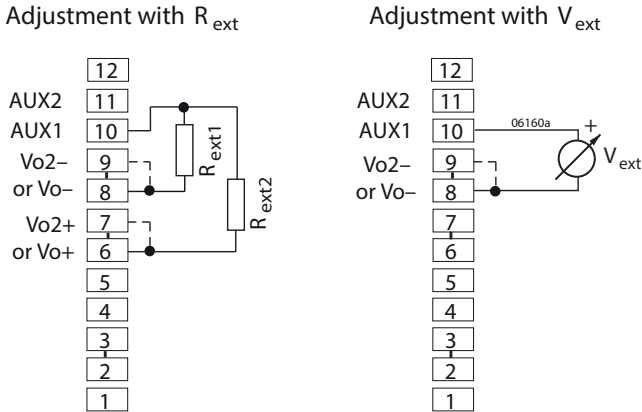

Fig. 17

Connection of adjust resistors or an external voltage source to adjust the output voltage V_o or V_{o2} (option M1 or M2 not fitted)

Multiple Options M1 or M2

The option board is suitable for applications, where several options are needed. Option M1 is standard for battery charger models, option M2 is suitable for applications without battery or for simple applications with battery.

In general, the multiple options M1 or M2 are connected to an additional D-SUB connector. Some signals (but not option R) can also be connected to AUX1 and AUX2, if the D-SUB connector is not suitable to the customer.

Table 15: Pin allocation of the 9 pin D-SUB connector

Pin	Designation	Description
1	GND1 ¹	System ground / common signal return
2	R	R input ³
3	VCC ²	Positive supply voltage (\approx output 2)
4	D1	Output voltage monitor $V_{o,low D1}$ ³
5	D5	Output 2 voltage monitor $V_{o,low D5}$ ³
6	SD	Shutdown ³
7	D-adj	Adjustment of threshold values of D1 or D5
8	D2	Input voltage monitor $V_{I,low}$
9	Sys-OK	System okay (all outputs are okay)

¹ Do not connect GND1 (pin 1) with the neg. output (-)
² Do not connect VCC (pin 3) with the positive output (+)
³ In double-output models, R, D1, D5, SD concern output 2 only.

Table 16a: Option board M1

Function	Description
R	Output voltage adjust ¹
D1	Output voltage monitor $V_{o,low D1}$ ¹
D2	Input voltage monitor $V_{i,low}$
D5	Output 2 voltage monitor ¹ (battery deep discharged): $V_{o,low D5}$
Sys-OK	System okay
SD	Shutdown ¹
D-adj	Adjustment of trigger values D1 and D5

Table 16b: Option board M2

Function	Description
R	Output voltage adjust ¹
D2	Input voltage monitor $V_{i,low}$
D5	Output voltage monitor ¹ (battery deep discharged): $V_{o,low D5}$
D-adj	Adjustment of trigger values D1 and D5

¹ In double-output models, only output 2 is concerned.

¹ In double-output models, only output 2 is concerned.

D2: Input Voltage Monitor (Power Fail)

D2 monitors the input voltage V_i . When V_i drops below 65 ± 3 VAC or 92 VDC, the D2 signal output is high impedance (open-collector, max. 50 V).

When V_i is greater than said level, the signal output D2 is conducting: $V_{D2} < 1.5$ V, $I_{D2,max} < 50$ mA.

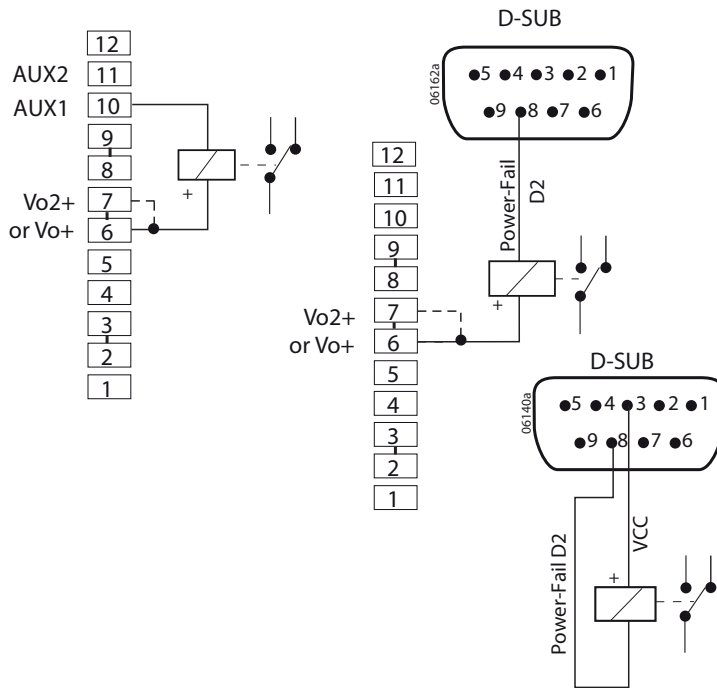

Fig. 18
Option D2: Examples of relay control to monitor a power failure

D1: Output Voltage Monitor

D1 is intended for monitoring the bus voltage of a battery-buffered system. It indicates that the system is powered from the battery and can for instance be used as warning signal or to switch off a part of the load. When the output voltage V_o (or V_{o2}) is greater than $V_{o,low D1}$ specified in table 17, the D1 signal output is conducting: $V_{D1} < 1.5$ V, $I_{D1,max} < 50$ mA.

When V_o is lower, the D1 signal output is high impedance (open-collector, max. 58.6 V). In double-output models, D1 monitors only output 2 (V_{o2}).

In applications without battery-buffering the D1 signal may not be suitable, since smaller dynamic load changes may cause D1 to trigger. For such applications, D5 with a trigger level of approx. 85% of $V_{o,nom}$ should be chosen (e.g., for a bus voltage of 24.7 V: trigger level at 21 V).

D5: System Volt. Monitor (Battery Deep Discharge)

D5 monitors the output voltage V_o (V_{o2} in double-output models) or the lowest admissible voltage of a connected battery (battery deep discharge). The definition of D5 is similar to D1, but the trigger level is lower. When V_o (or V_{o2}) is greater than $V_{o\ low\ D5}$ specified in table 17, the D2 signal output is conducting:

$$V_{D5} < 1.5\text{ V}, I_{D5\ max} < 50\text{ mA}.$$

When V_o is lower, the D5 signal output is high impedance (open-collector, max. 58.6 V). In double-output models, D5 monitors only output 2 (V_{o2}).

In systems without battery support, D5 signals that V_o (or V_{o2}) is going to drop below a safe value.

In battery-buffered systems, D5 indicates that the battery has reached its deepest discharge level prior to getting damaged.

The D5 signal can be used for instance to disable loads, save data, or to start a controlled switch-off of running processes.

Adjustment of Threshold Levels (D1 or D5)

Pin 7 of the D-SUB connector allows for adjustment of the threshold levels of D1 and D5. Both levels are influenced by the voltage divider R_x / R_y . Resistor R_x to pin 3 (VCC) lowers the levels, whereas R_y to pin 1 (GND1) increases them; see fig. 19.

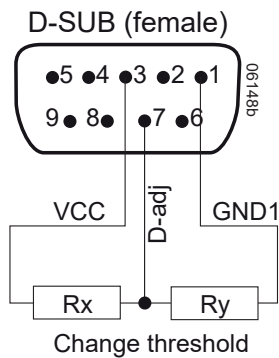

Fig. 19 Wiring to adjust both threshold levels of option D1 or D5

Table 18: Options D1 and D5: Trigger and switch-on levels

Model	Battery V_{Bat} [V]	$V_{o\ low\ D1}$		$V_{o\ low\ D5}$	
		trigger [V]	switch on [V]	trigger [V]	switch on [V]
LXR/LXN1140	12	11.5	12.1	10.5	12.1
LXR/LXN1240	24	23	24.2	21	24.2
LXR/LXN1840	36	34.4	36.3	31.5	36.3
LXR/LXN1740	48	46	48.4	42	48.4

SD: Shutdown

Reduces the output power to approx. 1 W, but the converter is not fully disabled. In a no-load condition, V_o drops below 6.2 V; see fig. 20. In double-output models, only output 2 is influenced.

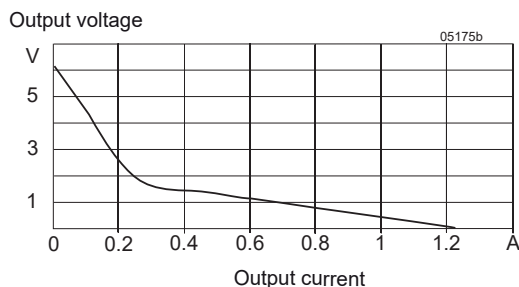

Fig. 20 Output voltage versus output current, while the shutdown is activated ($V_i = V_{i\ nom}$).

Table 19: Shutdown conditions

Voltage V_{SD} on shutdown pin	Result
< 0.7 V	Converter disabled (P_o approx. 1 W)
≥ 2.0 V or open	Converter enabled

Sys-OK: Status

This function allows in a battery charger application for checking, whether the output is correctly following the external control signal at the R-input (coming for instance from the temperature sensor). The logic is shown in table 19.

The open-collector output Sys-OK is protected by a Zener diode and withstands up to 58.6 V. When the system status is OK, the signal output is low: $V_{\text{Sys-OK}} < 1.5 \text{ V}$, $I_{\text{Sys-OK}} < 50 \text{ mA}$.

Table 20: System OK (M1 with external battery sensor)

System Status	Input	V_{control} sensor signal	V_{Bat} theoretical	V_{Bat} measured	Sys-OK Output
System OK	OK	2.7 V	27 V	27 V	Low ohmic
Battery overcharged / temp. sensor defect / control voltage to high	OK	2.7 V	27 V	28 V	High ohmic
Overload, converter cannot follow the control signal	OK	2.7 V	27 V	24 V	High ohmic
Output does not follow control signal, since battery would be overcharged	OK	3.0 V	30 V	27 V	High ohmic
System OK	OK	2.5 V	25 V	25 V	Low ohmic

R: Adjustment of V_o or V_{o2}

The R input allows external adjustment of the output voltage in the range of 50% to 110% $V_{o \text{ nom}}$. Double-output models allow only adjustment of output 2 (connected to the terminals 6, 7, 8, and 9). This enables asymmetric output voltage configuration.

Adjustment can be achieved via a resistor or an external voltage source (in the range of 1.25 – 2.75 V).

Note: If the R input is not connected: V_o or $V_{o2} \approx V_{o \text{ nom}}$.

a) Adjustment by an external resistor:

Resistor R_{ext1} , connected between R (pin 2) and GND1 (pin 1) of the D-SUB connector or according to fig. 20.

$$V_o = 50 - 100\% V_{o \text{ nom}} \quad R_{\text{ext1}} \approx 4 \text{ k}\Omega \cdot \frac{V_o}{V_{o \text{ nom}} - V_o}$$

Resistor R_{ext2} , connected between R (pin 2) and VCC (pin 3) of the D-SUB connector or according to fig. 17.

$$V_o = 100 - 110\% V_{o \text{ nom}} \quad R_{\text{ext2}} \approx 4 \text{ k}\Omega \cdot \frac{V_o - 2.5 \text{ V}}{2.5 \text{ V} \cdot (V_o / V_{o \text{ nom}} - 1)}$$

Note: If the R function is not included in M1 or M2, refer to figure 20 how to connect R_{ext1} or R_{ext2} .

b) Adjustment by an external control voltage V_{ext} (1.25 – 2.75 V), connected between R (pin 2) and GND (pin 1) of the D-SUB connector or according to fig. 20.

$$V_{\text{ext}} \approx 2.5 \text{ V} \cdot \frac{V_o}{V_{o \text{ nom}}} \quad V_o \approx V_{o \text{ nom}} \cdot \frac{V_{\text{ext}}}{2.5 \text{ V}}$$

Caution: To prevent damage, V_{ext} should not exceed 3 V, nor be negative.

Note: If longer wires are used to connect the R input at the D-SUB connector, the wiring to pin 1 (GND1) should be done as a star point connection. If wired differently, the output voltage setting may be adversely affected.

In battery charging systems, an external battery temperature sensor (see *Accessories*) can be connected to optimize V_o . However, adjustment using the R input (pin 2 of D-SUB) is possible as well. The above shown formulas are valid, but $V_{o \text{ nom}}$ stands for the voltage with open R input (= $V_{o \text{ safe}}$).

F: Built-in Second Fuse

A built-in second fuse in the neutral line provides safe phase-to-phase connection at low mains voltages (e.g. USA 120/208 V /60Hz systems).

The built-in second fuse also enables safe connection to the mains, where phase and neutral are not defined or cannot be identified, as e.g. in the case of plug and socket connection to the mains via German Schuko-plugs; see also *Safety and Installation Instructions*.

Option F limits the DC input voltage to $\leq 250 \text{ V}$.

K2: System Connectors

For installation in systems using pre-assembled harnesses the converters are available with system connectors. They are UL-listed, approved for currents up to 15 A at -40 to 105 °C.

The mating system connectors with screw terminals and retainers are delivered together with every converter with option K2. Use max. 2.5 mm² (AWG 12) solid or stranded wires, or max. 1.5 mm² (AWG 14) stranded wires with crimp termination, stripped length 6 mm. Tightening torque of input/output terminals: max. 0.79 Nm (7 lbs.in.).

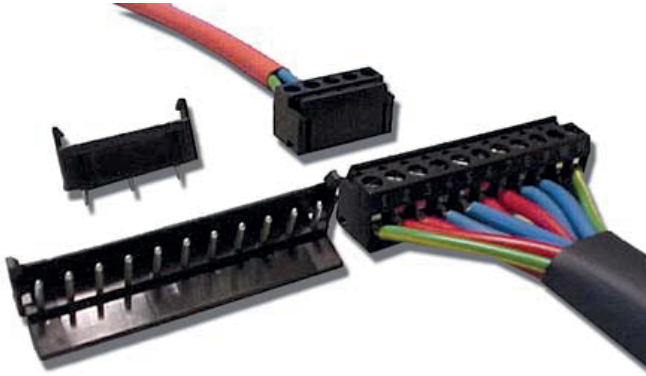

Fig. 21
System connectors Option K2

G: RoHS

RoHS compliant for all six substances.

Accessories

Shock-Resistant Wall Mounting

Set of wall mounting brackets HZZ00618-G (UMB-W)

Content: 2 clamps, 4 countersunk screws M4, washers, and spring washers

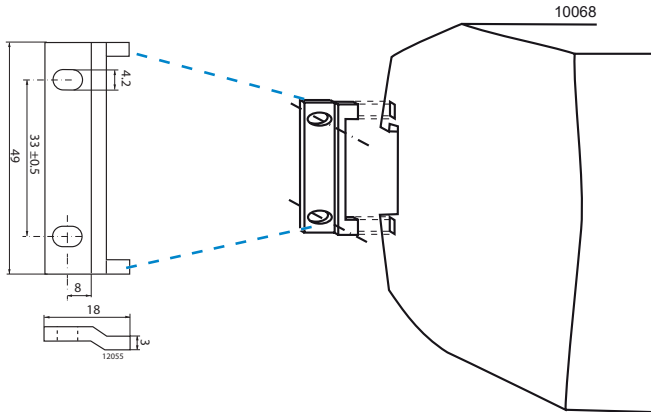

Fig. 22
Wall mounting with mounting brackets HZZ00618-G

DIN-Rail Fixing Brackets HZZ00624-G

For DIN-Rail vibration-proof fastening, use a set of brackets HZZ00624-G (DMB-EWG). For heavy-duty application 2 sets (= 4 brackets) are preferable.

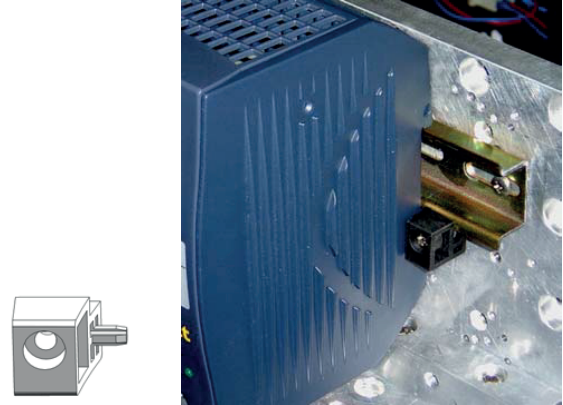

Fig. 23
DIN-rail fixing bracket HZZ00624-G (DMB-EWG)

Protective Covers over Terminals

Protective covers are available to avoid touching of the terminals. HZZ01220-G contains in a bag a plastic cover with length $A = 26.5$ mm for the primary terminals and a second cover with length $A = 64$ mm for the secondary terminals; see fig. 23.

Content: 2 covers to protect the input and output terminals.

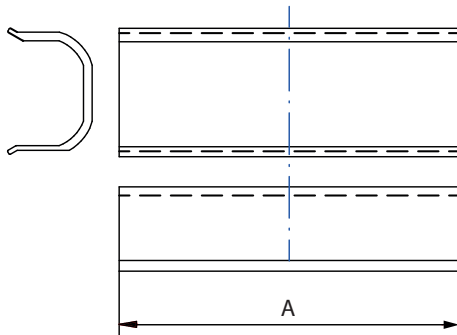
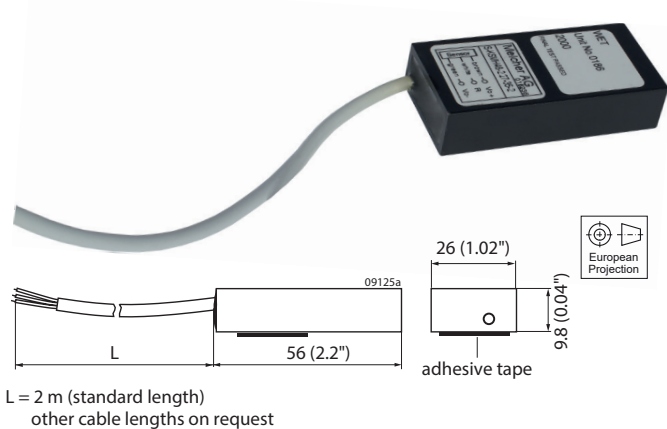

Fig. 24
Protective covers HZZ01220-G

Battery Temperature Sensor

To charge lead-acid batteries according to their temperature different types of temperature sensors are available, (see *Temperature Sensor data sheet*).



L = 2 m (standard length)
other cable lengths on request

Fig. 25
Temperature sensor

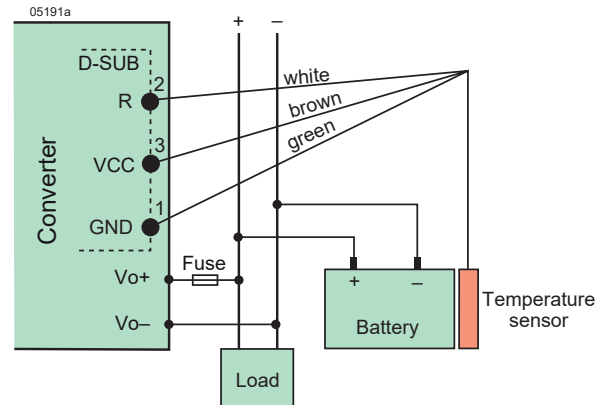

Fig. 26
Connection of temperature sensor

Table 20: Sensors for converters with standard R-input

Battery voltage nom. [V]	Sensor type	Cell voltage [V]	Cell temp. coefficient [mV/K]	Cable length [m]
12	S-KSMH12-2.27-30-2	2.27	-3.0	2
12	S-KSMH12-2.27-35-2	2.27	-3.5	2
24	S-KSMH24-2.27-30-2	2.27	-3.0	2
24	S-KSMH24-2.27-35-2	2.27	-3.5	2
24	S-KSMH24-2.31-35-0	2.31	-3.5	4.5
24	S-KSMH24-2.31-35-2	2.31	-3.5	2
24	S-KSMH24-2.35-35-2	2.35	-3.5	2
48	S-KSMH48-2.27-30-2	2.27	-3.0	2
48	S-KSMH48-2.27-35-2	2.27	-3.5	2

For additional accessory product information, see the accessory data sheets listed with each product series or individual model at our website.

NUCLEAR AND MEDICAL APPLICATIONS - These products are not designed or intended for use as critical components in life support systems, equipment used in hazardous environments, or nuclear control systems.

TECHNICAL REVISIONS - The appearance of products, including safety agency certifications pictured on labels, may change depending on the date manufactured. Specifications are subject to change without notice.