

# PET2000-NAS446

## AC-DC Front-End Power Supply

PET2000-NAS446 is a 2000 Watt AC to DC, power-factor corrected (PFC) power supply that converts standard AC power into a main output of +12 VDC.

PET2000-NAS446 utilizes full digital control architecture for greater efficiency, control and functionality.

The unit includes four 450 mm long cables with 20 pin connectors. The four connectors are intended to be attached directly to individual mining load boards.

This power supply meets international safety standards and displays the CE-Mark for the European Low Voltage Directive (LVD).



### Key Features & Benefits

- Best-in-class, 80 PLUS “Platinum” Efficiency
- Auto-Selected Input Voltage Ranges: 90 - 140 VAC, 180 - 264 VAC
- AC Input with Power Factor Correction
- 2000 W Continuous Output Power Capability
- Output cable wire harness set included
- Always-On 12 V Standby Output
- Full Digital Controls for Improved Performance
- High Density Design
- Small Form Factor: 73.5 x 40.0 x 331.6 mm (2.89 x 1.57 x 13.05 in)
- Power Management Bus Communication Interface for Control, Programming and Monitoring
- Status LED with Fault Signaling

### Applications

- Cryptocurrency Mining
- Blockchain Applications
- Networking Switches
- Servers & Routers



**bel** POWER  
SOLUTIONS &  
PROTECTION

a bel group

[belfuse.com/power-solutions](http://belfuse.com/power-solutions)

### 1. ORDERING INFORMATION

PET	2000	-	N	A	Sxxx
<b>Product Family</b>	<b>Power Level</b>	<b>Dash</b>	<b>Airflow</b>	<b>Input</b>	<b>Suffix</b>
PET Front-Ends	2000 W		N: Normal (Rear to front)	A: AC	S446:

### 2. OVERVIEW

The PET2000-NAS446 AC/DC power supply is a fully DSP controlled, highly efficient front-end power supply. It incorporates resonance-soft-switching technology to reduce component stresses, providing increased system reliability and very high efficiency. With a wide input operational voltage range the PET2000-NAS446 maximizes power availability in demanding server, network, and other high availability applications. The supply is fan cooled and ideally suited for integration with a matching airflow path.

The PFC stage is digitally controlled using a state-of-the-art digital signal processing algorithm to guarantee best efficiency and unity power factor over a wide operating range.

The DC/DC stage uses soft switching resonant techniques in conjunction with synchronous rectification.

The always-on standby output provides power to external power distribution and management controllers.

Status information is provided with a front-panel LED. In addition, the power supply can be controlled and the fan speed set via the I2C bus. The I2C bus allows full monitoring of the supply, including input and output voltage, current, power, and inside temperatures.

Cooling is managed by a fan controlled by the DSP controller. The fan speed is adjusted automatically depending on the actual power demand and supply temperature and can be overridden through the I<sup>2</sup>C bus.

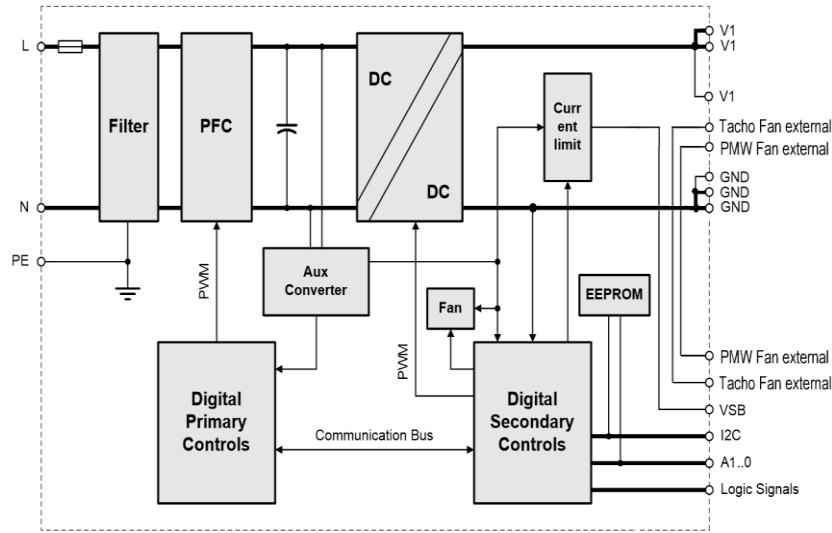

Figure 1. PET2000-NAS446 Block Diagram

### 3. ABSOLUTE MAXIMUM RATINGS

Stresses in excess of the absolute maximum ratings may cause performance degradation, adversely affect long-term reliability and cause permanent damage to the supply.

PARAMETER	CONDITIONS / DESCRIPTION	MIN	MAX	UNITS
<i>V<sub>i maxc</sub></i>	Maximum Input	Continuous	264	VAC

## 4. INPUT

General Condition:  $T_A = 0 \dots 55 \text{ }^\circ\text{C}$ , unless otherwise noted.

PARAMETER	DESCRIPTION / CONDITION	MIN	NOM	MAX	UNIT	
$V_{i\text{nom}}$	Nominal Input Voltage	Rated Voltage High Line ( $V_{i\text{nom HL}}$ )	200	230	240	VAC
		Rated Voltage Low Line ( $V_{i\text{nom LL}}$ )	100	115	127	VAC
$V_i$	Input Voltage Ranges	Normal operating ( $V_{i\text{min HL}}$ to $V_{i\text{max HL}}$ ), High Line	180		264	VAC
		Normal operating ( $V_{i\text{min LL}}$ to $V_{i\text{max LL}}$ ), Low Line	90		140	VAC
$I_{i\text{max}}$	Maximum Input Current	$V_i=100 \text{ VAC}$ , $I_l=83 \text{ A}$ , $I_{SB}=3 \text{ A}$			13	
		$V_i=200 \text{ VAC}$ , $I_l=167 \text{ A}$ , $I_{SB}=3 \text{ A}$ (North America)			12	
		$V_i=200 \text{ VAC}$ , $I_l=145 \text{ A}$ , $I_{SB}=3 \text{ A}$ (other than North America)			10	A <sub>RMS</sub>
		$V_i=220 \text{ VAC}$ , $I_l=158 \text{ A}$ , $I_{SB}=3 \text{ A}$ (America)			10	
$I_{i\text{inrush}}$	Inrush Current Limitation	$V_i=230 \text{ VAC}$ , $I_l=167 \text{ A}$ , $I_{SB}=3 \text{ A}$			10	
		$V_i=230 \text{ VAC}$ , $I_l=167 \text{ A}$ , $I_{SB}=3 \text{ A}$			10	A <sub>p</sub>
$f_i$	Input Frequency		47	50/60	63	Hz
$PF$	Power Factor	$V_i=230 \text{ VAC}$ , 10% load	0.8	0.88		W/VA
		$V_i=230 \text{ VAC}$ , 20% load	0.9	0.95		W/VA
		$V_i=230 \text{ VAC}$ , 50% load	0.9	0.997		W/VA
		$V_i=230 \text{ VAC}$ , 100% load	0.95	0.999		W/VA
$THD$	Total Harmonic Distortion	TBD			TBD	%
$V_{i\text{on}}$	Turn-on Input Voltage <sup>1</sup>	Ramping up	87		90	VAC
$V_{i\text{off}}$	Turn-off Input Voltage <sup>2</sup>	Ramping down	82		87	VAC
$\eta$	Efficiency <sup>2</sup>	$V_i=230 \text{ VAC}$ , 10% load	90	91.6		%
		$V_i=230 \text{ VAC}$ , 20% load	91	93.8		%
		$V_i=230 \text{ VAC}$ , 50% load	94	94.4		%
		$V_i=230 \text{ VAC}$ , 100% load	91	92.8		%
$T_{V1\text{ holdup}}$	Hold-up Time $V_i$	$V_i=230 \text{ VAC}$ , 50% load, 0°	18			ms
		$V_i=230 \text{ VAC}$ , 100% load, 0°	9			ms
$T_{VSB\text{ holdup}}$	Hold-up Time $V_{SB}$	$V_i=90$ to $264 \text{ VAC}$ , 0 to 100% load	70			ms

<sup>1</sup> The Front-End is provided with a minimum hysteresis of 3 V during turn-on and turn-off within the ranges

<sup>2</sup> Efficiency measured without fan power per EPA server guidelines

## 4.1 INPUT CONNECTOR

The PET2000-NAS446 power supply is available with IEC 60320-C14. Outside North America the IEC 60320-C14 has a limited current of 10 A and is allowed to operate up to 70 °C ambient.

Below table shows the maximum rated operating conditions for the different input connector options. The applied operating condition must remain within these conditions to allow safety compliant operation.

See also [10.3 MAXIMUM OUTPUT POWER VERSUS INLET TEMPERATURE FOR SAFETY COMPLIANCY](#) for detailed derating curves.

TYPE	INPUT CONNECTOR	REGION	APPLIED RATED MAINS AC VOLTAGE <sup>3</sup>	MAX I <sup>4</sup>	MAXIMUM DERATED I <sub>r</sub> AT MAXIMUM T <sub>A</sub>
PET2000-NAS446	IEC 60320-C14	North America	100 to 127 VAC	83 A	50 A at T <sub>A</sub> = 70°C
			200 to 240 VAC	167 A	80 A at T <sub>A</sub> = 70°C
		Other than North America	100 to 127 VAC	67 A	17.5 A at T <sub>A</sub> = 65°C
			200 to 220 VAC	145 A	32.5 A at T <sub>A</sub> = 65°C
			220 to 230 VAC	158 A	40 A at T <sub>A</sub> = 65°C
			230 to 240 VAC	167 A	43 A at T <sub>A</sub> = 65°C

## 4.2 INPUT FUSE

Time-lag 16 A input fuse (5 x 20 mm) in series with the L-line inside the power supply protects against severe defects. The fuse is not accessible from the outside and is therefore not a serviceable part.

## 4.3 INRUSH CURRENT

The AC-DC power supply exhibits an X-capacitance of only 5.9 µF, resulting in a low and short peak current, when the supply is connected to the mains. The internal bulk capacitor will be charged through an NTC which will limit the inrush current.

### NOTE:

Do not repeat plug-in / out operations within a short time, or else the internal in-rush current limiting device (NTC) may not sufficiently cool down and excessive inrush current or component failure(s) may result.

## 4.4 INPUT UNDER-VOLTAGE

If the sinusoidal input voltage stays below the input undervoltage lockout threshold V<sub>i on</sub>, the supply will be inhibited. Once the input voltage returns within the normal operating range, the supply will return to normal operation again.

## 4.5 POWER FACTOR CORRECTION

Power factor correction (PFC) is achieved by controlling the input current waveform synchronously with the input voltage. A fully digital controller is implemented giving outstanding PFC results over a wide input voltage and load ranges. The input current will follow the shape of the input voltage. If for instance the input voltage has a trapezoidal waveform, then the current will also show a trapezoidal waveform.

<sup>3</sup> Nominal grid voltage, does not include typical fluctuations of ±10%; e.g. listed range 230-240 VAC allows operation at 230 VAC -10% to 240 VAC +10%, so 207 ... 264 VAC actual voltage to account for grid fluctuations

<sup>4</sup> Maximum Input current for PET2000-NAS446 at T<sub>A</sub> = 55°C

4.6 EFFICIENCY

High efficiency (see *Figure 2*) is achieved by using state-of-the-art silicon power devices in conjunction with soft-transition topologies minimizing switching losses and a full digital control scheme. Synchronous rectifiers on the output reduce the losses in the high current output path. The speed of the fan is digitally controlled to keep all components at an optimal operating temperature regardless of the ambient temperature and load conditions.

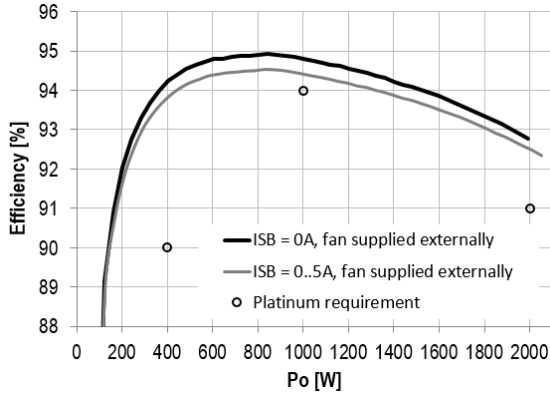

Figure 2. Efficiency vs. Load current (ratio metric loading)

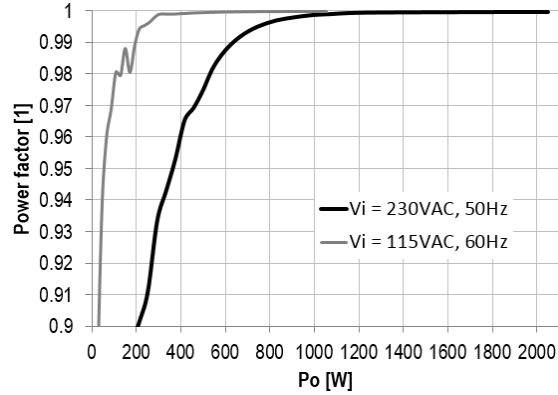

Figure 3. Power factor vs. Load current

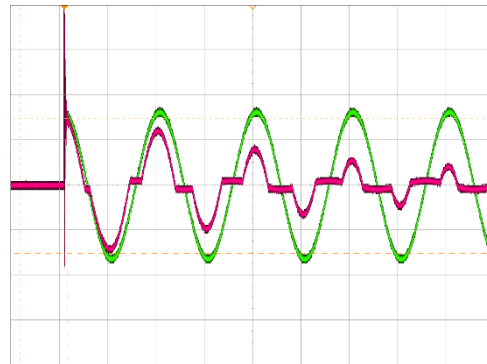

Figure 4. Inrush current,  $V_i = 230Vac, 90^\circ$   
 CH2:  $V_i$  (200V/div), CH3:  $I_i$  (5A/div)

## 5. OUTPUT

### 5.1 MAIN OUTPUT $V_1$

General Condition:  $T_A = 0 \dots 55 \text{ }^\circ\text{C}$ ,  $V_i = 230 \text{ VAC}$  unless otherwise noted.

PARAMETER	DESCRIPTION / CONDITION	MIN	NOM	MAX	UNIT	
$V_{1 \text{ nom}}$	Nominal Output Voltage		12.0		VDC	
$V_{1 \text{ set}}$	Output Setpoint Accuracy	-0.5		+0.5	% $V_{1 \text{ nom}}$	
$dV_{1 \text{ tot}}$	Static Regulation	$V_{1 \text{ min LL}}$ to $V_{1 \text{ max HL}}$ , 0 to 100% $I_{1 \text{ nom}}$			% $V_{1 \text{ nom}}$	
$P_{1 \text{ nom}}$	Nominal Output Power <sup>5</sup>	$V_{1 \text{ min HL}}$ to $V_{1 \text{ max HL}}$	2000		W	
		$V_{1 \text{ min LL}}$ to $V_{1 \text{ max LL}}$	1000		W	
$P_{1 \text{ peak}}$	Peak Output Power <sup>6</sup>	$V_{1 \text{ min HL}}$ to $V_{1 \text{ max HL}}$	2100		W	
		$V_{1 \text{ min LL}}$ to $V_{1 \text{ max LL}}$	110		W	
$I_{1 \text{ nom}}$	Output Current	$V_{1 \text{ min HL}}$ to $V_{1 \text{ max HL}}$	0	167	ADC	
$I_{1 \text{ nom red}}$		$V_{1 \text{ min LL}}$ to $V_{1 \text{ max LL}}$	0	83	ADC	
$I_{1 \text{ peak}}$	Peak Output Current <sup>6</sup>	$V_{1 \text{ min HL}}$ to $V_{1 \text{ max HL}}$		175	ADC	
$I_{1 \text{ peak red}}$		$V_{1 \text{ min LL}}$ to $V_{1 \text{ max LL}}$		110	ADC	
$V_{1 \text{ pp}}$	Output Ripple Voltage <sup>7</sup>	$V_{1 \text{ min LL}}$ to $V_{1 \text{ max HL}}$ , 0 to 75% $I_{1 \text{ nom}}$ , $C_{\text{ext}} = 0 \text{ mF}$		120	mVpp	
		$V_{1 \text{ min LL}}$ to $V_{1 \text{ max HL}}$ , 75 to 100% $I_{1 \text{ nom}}$ , $C_{\text{ext}} = 0 \text{ mF}$		150	mVpp	
		$V_{1 \text{ min LL}}$ to $V_{1 \text{ max HL}}$ , 0 to 100% $I_{1 \text{ nom}}$ , $C_{\text{ext}} \geq 1 \text{ mF/Low ESR}$		120	mVpp	
$dV_{1 \text{ load}}$	Load Regulation	0 to 100% $I_{1 \text{ nom}}$	-30		mV	
$dV_{1 \text{ line}}$	Line Regulation	$V_{1 \text{ min HL}}$ to $V_{1 \text{ max HL}}$ , $0.5 \cdot I_{1 \text{ nom}}$	-24	0	24	mV
$dV_{1 \text{ temp}}$	Thermal Drift	$0.5 \cdot I_{1 \text{ nom}}$ , $T_A = 0 \dots 55^\circ\text{C}$	-0.4		mV/ $^\circ\text{C}$	
$dV_{1 \text{ lt}}$	Load Transient Response	$\Delta I_1 = 50\% I_{1 \text{ nom}}$ , $I_1 = 5 \dots 100\% I_{1 \text{ nom}}$ , $C_{\text{ext}} = 0 \text{ mF}$	0.35	0.6	VDC	
$dV_{1 \text{ lt}}$		$\Delta I_1 = 10\% I_{1 \text{ nom}}$ , $I_1 = 0 \dots 10\% I_{1 \text{ nom}}$ , $C_{\text{ext}} = 0 \text{ mF}$	0.35	0.6	VDC	
$t_{\text{rec}}$	Recovery Time	$dI_1/dt = 1\text{A}/\mu\text{s}$ , recovery within 1% of $V_{1 \text{ nom}}$	0.5	1	ms	
$V_{1 \text{ dyn}}$	Dynamic Load Regulation	$\Delta I_1 = 60\% I_{1 \text{ nom}}$ , $I_1 = 5 \dots 167 \text{ A}$ , $f = 50 \dots 5000 \text{ Hz}$ , Duty cycle = 10 ... 90%, $C_{\text{ext}} = 2 \dots 30 \text{ mF}$	11.4		12.6	V
$t_{V1 \text{ rise}}$	Output Voltage Rise Time	$V_1 = 10 \dots 90\% V_{1 \text{ nom}}$ , $C_{\text{ext}} < 10 \text{ mF}$	1		30	ms
$t_{V1 \text{ ovr sh}}$	Output Turn-on Overshoot	0 to 100% $I_{1 \text{ nom}}$			0.6	V
$C_{V1 \text{ load}}$	Capacitive Loading		0		30	mF

<sup>5</sup> See also chapter [TEMPERATURE AND FAN CONTROL](#)

<sup>6</sup> Peak combined power for all outputs must not exceed 2100 W; maximum of peak power duration is 20 seconds without asserting the SMBAlert signal

<sup>7</sup> Measured with a 10  $\mu\text{F}$  low ESR capacitor in parallel with a 0.1  $\mu\text{F}$  ceramic capacitor at the point of measurement

## 5.2 STANBY OUTPUT $V_{SB}$

General Condition:  $T_A = 0 \dots 55 \text{ }^\circ\text{C}$ ,  $V_i = 230 \text{ VAC}$  unless otherwise noted.

PARAMETER	DESCRIPTION / CONDITION	MIN	NOM	MAX	UNIT
$V_{SB \text{ nom}}$	Nominal Output Voltage $I_{SB} = 0 \text{ A}$ , $T_A = 25^\circ\text{C}$		12.1		VDC
$V_{SB \text{ set}}$	Output Setpoint Accuracy	-1		+1	% $V_{SB \text{ nom}}$
$dV_{SB \text{ tot}}$	Total Regulation $V_{i \text{ min LL}}$ to $V_{i \text{ max HL}}$ , 0 to 100% $I_{SB \text{ nom}}$	-5		+1	% $V_{SB \text{ nom}}$
$P_{SB \text{ nom}}$	Nominal Output Power $V_{i \text{ min LL}}$ to $V_{i \text{ max HL}}$		PET2000-NAS446 36		W
$I_{SB \text{ nom}}$	Output Current $V_{i \text{ min LL}}$ to $V_{i \text{ max HL}}$		PET2000-NAS446 0	3	ADC
$V_{SB \text{ pp}}$	Output Ripple Voltage <sup>7</sup> $V_{i \text{ min LL}}$ to $V_{i \text{ max HL}}$ , 0 to 100% $I_{SB \text{ nom}}$ , $C_{\text{ext}} = 0 \text{ mF}$			120	mVpp
$dV_{SB \text{ load}}$	Load Regulation 0 to 100% $I_{SB \text{ nom}}$		PET2000-NAS446 -360		mV
$dV_{SB \text{ line}}$	Line Regulation $V_{i \text{ min HL}}$ to $V_{i \text{ max HL}}$ , $I_{SB \text{ nom}} = 0 \text{ A}$	-24	0	24	mV
$dV_{SB \text{ temp}}$	Thermal Drift $I_{SB} = 0 \text{ A}$		-0.5		mV/ $^\circ\text{C}$
$V_{SB \text{ dyn}}$	Load Transient Response $\Delta I_{SB} = 50\% I_{SB \text{ nom}}$ , $I_{SB} = 5 \dots 100\% I_{SB \text{ nom}}$ , $dI_{SB}/dt = 1 \text{ A}/\mu\text{s}$ , recovery within 1% of $V_{SB \text{ nom}}$		0.2	0.3	VDC
$t_{\text{rec}}$	Recovery Time $\Delta I_{SB} = 50\% I_{SB \text{ nom}}$ , $I_{SB} = 5 \dots 100\% I_{SB \text{ nom}}$ , $dI_{SB}/dt = 1 \text{ A}/\mu\text{s}$ , recovery within 1% of $V_{SB \text{ nom}}$		1	2	ms
$V_{SB \text{ dyn}}$	Dynamic Load Regulation $\Delta I_{SB} = 1 \text{ A}$ , $I_{SB} = 0 \dots I_{SB \text{ nom}}$ , $f = 50 \dots 5000 \text{ Hz}$ , Duty cycle = 10 ... 90%, $C_{\text{ext}} = 0 \dots 5 \text{ mF}$	11.4		12.6	V
$t_{V_{SB} \text{ rise}}$	Output Voltage Rise Time $V_{SB} = 10 \dots 90\% V_{SB \text{ nom}}$ , $C_{\text{ext}} < 1 \text{ mF}$	1	2	5	ms
$t_{V_{SB} \text{ ovr sh}}$	Output Turn-on Overshoot 0 to 100% $I_{SB \text{ nom}}$			0.6	V
$C_{V_{SB} \text{ load}}$	Capacitive Loading	0		3100	$\mu\text{F}$

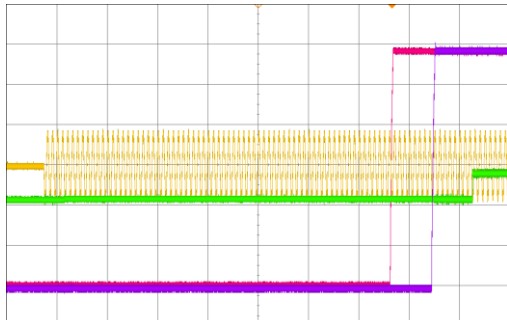

Figure 5. Turn-On AC Line 230VAC, full load (200ms/div)  
CH1:  $V_{in}$  (400V/div) CH2: PWOK\_H (5V/div)  
CH3:  $V_i$  (2V/div) CH4:  $V_{SB}$  (2V/div)

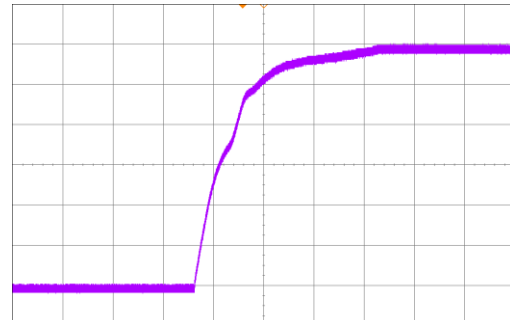

Figure 6. Rise time  $V_i$  at 230VAC, full load (2ms/div)  
CH3:  $V_i$  (2V/div)

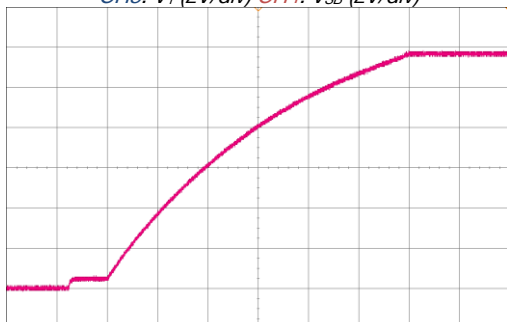

Figure 7. Rise time  $V_{SB}$  at 230VAC, full load (2ms/div)  
CH4:  $V_{SB}$  (2V/div)

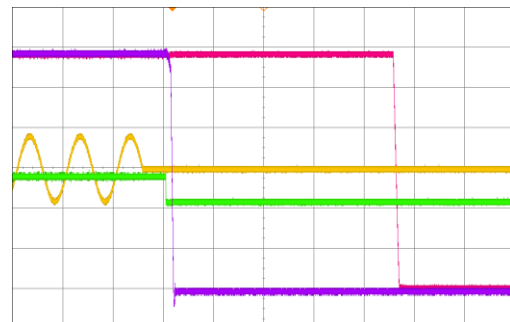

Figure 8. Turn-Off AC Line 230VAC, full load (20ms/div)  
CH1:  $V_{in}$  (400V/div) CH2: PWOK\_H (5V/div)  
CH3:  $V_i$  (2V/div) CH4:  $V_{SB}$  (2V/div)

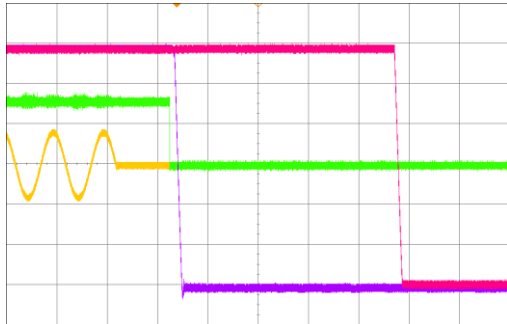

Figure 9. Turn-Off AC Line 230VAC, half load (20ms/div)  
 CH1:  $V_{in}$  (400V/div) CH2: PWOK\_H (5V/div)  
 CH3:  $V_1$  (2V/div) CH4:  $V_{SB}$  (2V/div)

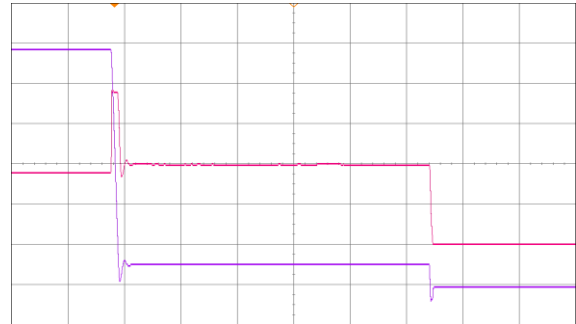

Figure 10. Short circuit on  $V_1$  (10ms/div)  
 CH3:  $V_1$  (2V/div) CH4:  $I_1$  (100A/div)

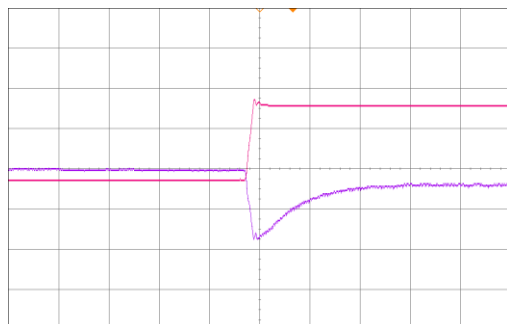

Figure 11. Load transient  $V_1$ , 83 to 167A (500 $\mu$ s/div)  
 CH3:  $V_1$  (200mV/div) CH4:  $I_1$  (50A/div)

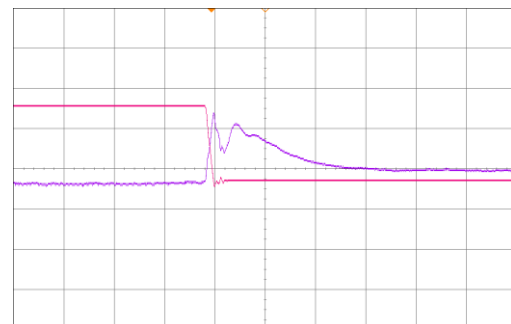

Figure 12. Load transient  $V_1$ , 167 to 83A (500 $\mu$ s/div)  
 CH3:  $V_1$  (200mV/div) CH4:  $I_1$  (50A/div)

### 5.3 OUTPUT GROUND / CHASSIS CONNECTION

The output return path serves as power and signal ground. All output voltages and signals are referenced to these pins. To prevent a shift in signal and voltage levels due to ground wiring voltage drop a low impedance ground plane should be used as shown in Figure 13. Alternatively, separated ground signals can be used as shown in

Figure 14. In this case the two ground planes should be connected together at the power supplies ground pins.

**NOTE:**

Within the power supply the output GND pins are connected to the Chassis, which in turn is connected to the Protective Earth terminal on the AC inlet. Therefore, it is not possible to set the potential of the output return (GND) to any other than Protective Earth potential.

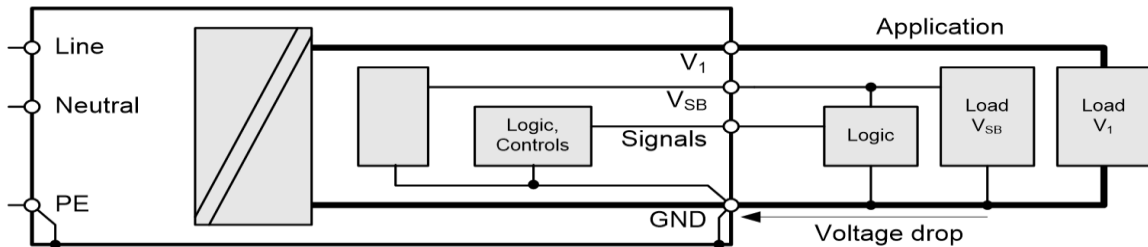

Figure 13. Common low impedance ground plane

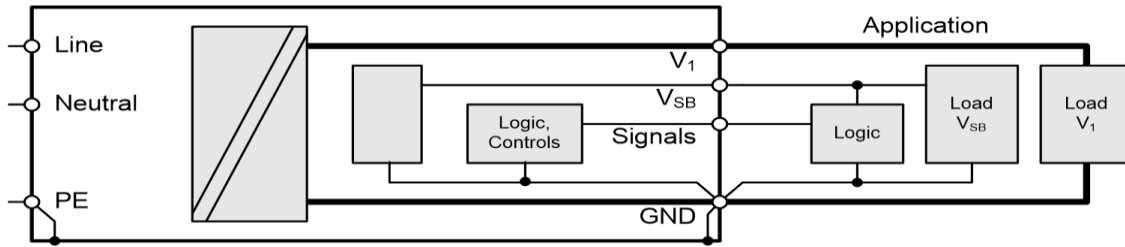

Figure 14. Separated power and signal ground

## 6. PROTECTION

PARAMETER	DESCRIPTION / CONDITION	MIN	NOM	MAX	UNIT	
$F$	Input fuse (L)	Not use accessible, time-lag (T)			A	
$V_{1\ OV}$	OV Threshold $V_1$	13.3	13.9	14.5	VDC	
$t_{V1\ OV}$	OV Trip Time $V_1$	Over Voltage $V_1$ Protection, Latch-off Type			1 ms	
$V_{SB\ OV}$	OV Threshold $V_{SB}$	13.3	13.9	14.5	VDC	
$t_{VSB\ OV}$	OV Trip Time $V_{SB}$	Over Voltage $V_1$ Protection, Automatic retry each 1s			1 ms	
$I_{1\ OC\ Slow}$	OC Limit $V_1$	Over Current Limitation, Latch-off, $V_{1\ min\ HL}$ to $V_{1\ max\ HL}$			175 ADC	
		Over Current Limitation, Latch-off, $V_{1\ min\ LL}$ to $V_{1\ max\ LL}$			88 ADC	
$t_{V1\ OC\ Slow}$	OC Trip time $V_1$	Over Current Limitation, Latch-off time			20 s	
$I_{V1\ OC\ Fast}$	Fast OC Limit $V_1$	Fast Over Current Limit., Latch-off, $V_{1\ min\ HL}$ to $V_{1\ max\ HL}$			180 ADC	
		Fast Over Current Limit., Latch-off, $V_{1\ min\ LL}$ to $V_{1\ max\ LL}$			115 ADC	
$t_{V1\ OC\ Fast}$	Fast OC Trip time $V_1$	Fast Over Current Limitation, Latch-off time			55 ms	
$I_{1\ SC}$	Max Short Circuit Current $I_1$	$V_1 < 3\ V$			180 A	
$t_{V1\ SC}$	Short Circuit Regulation Time	$V_1 < 3\ V$ , time until $I_1$ is limited to $< I_{1\ SC}$			2 ms	
$I_{SB\ OC}$	OC Limit $V_{SB}$	3.3	Over Current Limitation, Constant-Current Type			5.5 A
$t_{VSB\ OC}$	OC Trip time $V_{SB}$	Over Current Limit., time until $I_{SB}$ is limited to $I_{SB\ OC}$			1 ms	
$T_{SD}$	Over Temperature	See chapter 10.2			°C	

### 6.1 OVERVOLTAGE PROTECTION

PET2000-NAS446 front-end provides a fixed threshold overvoltage (OV) protection implemented with a HW comparator for both the main and the standby output. Once an OV condition has been triggered on the main output, the supply will shut down and latch the fault condition. The latch can be unlocked by disconnecting the supply from the AC mains or by toggling the PSON\_L input. The standby output will continuously try to restart with a 1 s interval after OV condition has occurred.

### 6.2 UNDERVOLTAGE DETECTION

Both main and standby outputs are monitored. LED and PWOK\_H pin signal if the output voltage exceeds  $\pm 5\%$  of its nominal voltage.

The main output will latch off if the main output voltage  $V_1$  falls below 10 V (typically in an overload condition) for more than 55 ms. The latch can be unlocked by disconnecting the supply from the AC mains or by toggling the PSON\_L input.

If the standby output leaves its regulation bandwidth for more than 2 ms then the main output is disabled to protect the system.

### 6.3 CURRENT LIMITATION

#### MAIN OUTPUT

The main output exhibits a substantially rectangular output characteristic controlled by a software feedback loop. If output current exceeds  $I_{V1\ OC\ Fast}$  it will reduce output voltage in order to keep output current at  $I_{V1\ OC\ Fast}$ . If the output voltage drops below  $\sim 10.0\text{ VDC}$  for more than 55 ms, the output will latch off (standby remains on), see also [Undervoltage Detection](#).

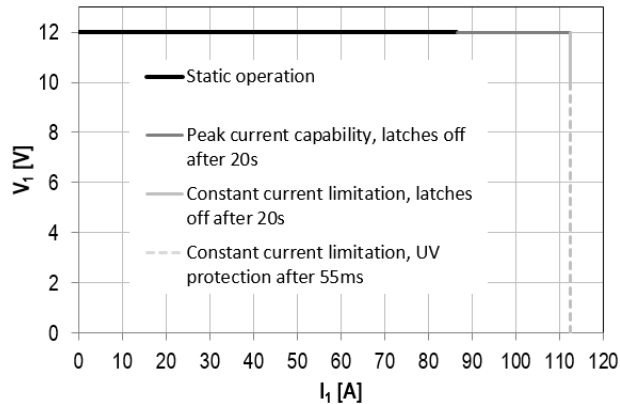

Figure 15. Current Limitation on  $V_1$  at  $V_i = 90 \dots 140\text{ VAC}$

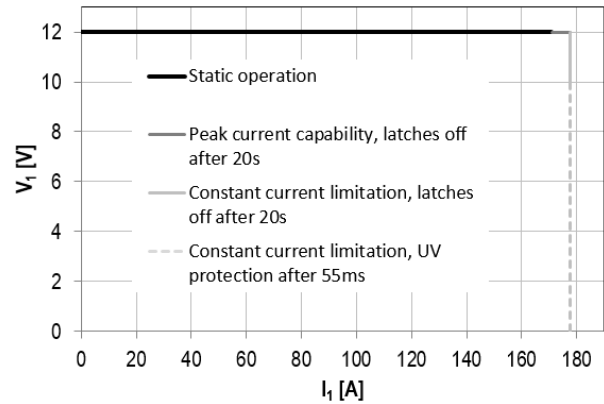

Figure 16. Current Limitation on  $V_1$  at  $V_i = 180 \dots 264\text{ VAC}$

## 7. MONITORING

The power supply operating parameters can be accessed through I<sup>2</sup>C interface. For more details refer to chapter [I2C / POWER MANAGEMENT BUS COMMUNICATION](#) and document URP.00686 (PET Front-End Power Management Bus Communication Manual).

PARAMETER	DESCRIPTION / CONDITION	MIN	NOM	MAX	UNIT
$V_{i\ mon}$	Input RMS Voltage $V_{i\ min\ LL} \leq V_i \leq V_{i\ max\ HL}$	-3		+3	VAC
$I_{i\ mon}$	Input RMS Current $I_i > 6.7\text{ Arms}$ $I_i \leq 6.7\text{ Arms}$	-3		+3	%
$P_{i\ mon}$	True Input Power $P_i > 500\text{ W}$ $50\text{ W} < P_i \leq 500\text{ W}$	-4		+4	%
$V_1\ mon$	V1 Voltage	-0.1		+0.1	VDC
$I_1\ mon$	V1 Current $I_1 > 50\text{ A}$ $5\text{ A} < I_1 \leq 50\text{ A}$	-1		+1	%
$P_1\ mon$	V1 Output Power $P_o > 1000\text{ W}$ $50\text{ W} < P_o \leq 1000\text{ W}$	-10		+10	W
$V_{SB\ mon}$	VSB Voltage	-0.1		+0.1	VDC
$I_{SB\ mon}$	VSB Current	-0.1		+0.1	ADC
$T_{A\ mon}$	Inlet Temperature $T_{A\ min} \leq T_A \leq T_{A\ max}$	-3		+3	°C

## 8. SIGNALING AND CONTROL

### 8.1 ELECTRICAL CHARACTERISTICS

PARAMETER	DESCRIPTION / CONDITION	MIN	NOM	MAX	UNIT
$I_{L,H}$	Maximum Input Sink or Source Current $V_I = -0.2\text{ V to }+3.5\text{ V}$	-1		1	mA
$R_{pull\ up}$	Internal Pull up Resistor to internal 3.3 V		10		k $\Omega$
$R_{LOW}$	Maximum external Pull down Resistance to GND to obtain Low Level			1	k $\Omega$
$R_{HIGH}$	Minimum external Pull down Resistance to GND to obtain High Level	50			k $\Omega$
PWOK_H					
$V_{OL}$	Output Low Level Voltage $V_I$ or $V_{SB}$ out of regulation, $V_{sink} < 4\text{ mA}$	0		0.4	V
$V_{OH}$	Output High Level Voltage $V_I$ and $V_{SB}$ in regulation, $I_{source} < 0.5\text{ mA}$	2.4		3.5	V
$R_{pull\ up}$	Internal Pull up Resistor to internal 3.3 V		1		k $\Omega$
$I_{OL}$	Maximum Sink Current $V_O < 0.4\text{ V}$			4	mA

### 8.2 PSON\_L INPUT

The PSON\_L is an internally pulled-up (3.3 V) input signal to enable/disable the main output  $V_I$  of the front-end. With low level input the main output is enabled. This active-low pin is also used to clear any latched fault condition. The PSON\_L can be either controlled by an open collector device or by a voltage source.

### 8.3 PWOK\_H OUTPUT

The PWOK\_H is an open drain output with an internal pull-up to 3.3 V indicating whether both  $V_{SB}$  and  $V_I$  outputs are within regulation. This pin is active-high.  
An external pull down resistor ensures low level when there is no power supply seated. When combining PWOK\_H outputs of several power supplies, circuits as shown in [Figure 17](#) should be used.

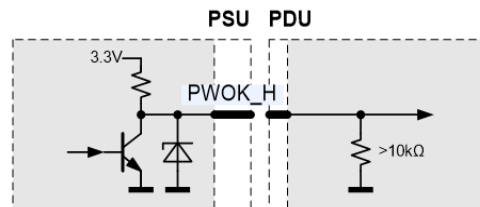

Figure 17. PWOK\_H Output

### 8.4 PRESENT\_L OUTPUT

The PRESENT\_L pin is wired through a 100 Ohms resistor to internal GND within the power supply. This pin does indicate that there is a power supply present in this system slot. An external pull-up resistor has to be added within the application. Current into PRESENT\_L should not exceed 5 mA to guarantee a low level voltage if power supply is seated.

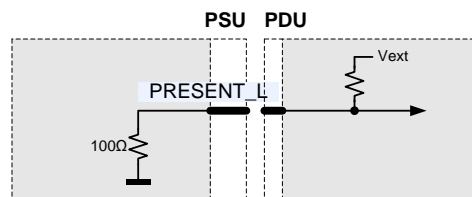

Figure 18. PRESENT\_L connection

8.5 SIGNAL TIMING

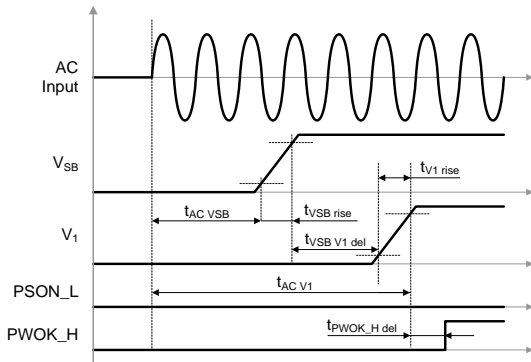

Figure 19. AC turn-on timing

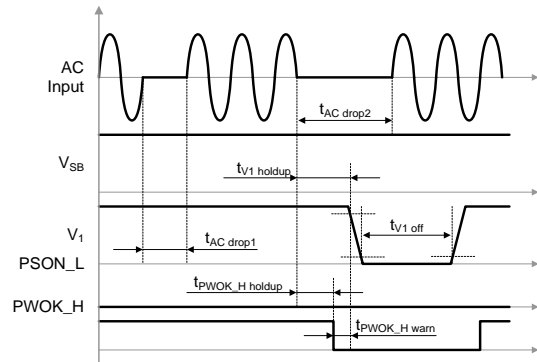

Figure 20. AC short dips

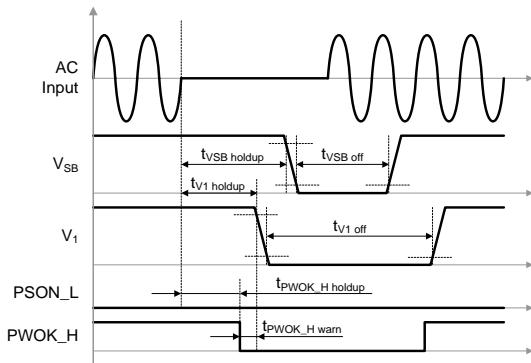

Figure 21. AC long dips

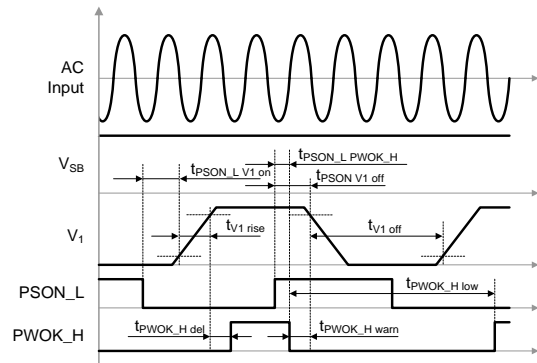

Figure 22. PSON\_L turn-on/off timing

PARAMETER	DESCRIPTION / CONDITION	MIN	NOM	MAX	UNIT		
$t_{AC\ VSB}$	AC Line to 90% $V_{SB}$			1.5	s		
$t_{AC\ V1}$	AC Line to 90% $V_1$		PSON_L = Low	1.5	4 <sup>8</sup> s		
$t_{VSB\ V1\ del}$	$V_{SB}$ to $V_1$ delay		PSON_L = Low	50	150	1000	ms
$t_{V1\ rise}$	$V_1$ rise time		See chapter <a href="#">OUTPUT</a>				
$t_{VSB\ rise}$	$V_{SB}$ rise time		See chapter <a href="#">OUTPUT</a>				
$t_{AC\ drop1}$	AC drop without $V_1$ leaving regulation			$0.5 \cdot I_{1\ nom}, I_{SB\ nom}$	17	ms	
				$0.7 \cdot I_{1\ nom}, I_{SB\ nom}$	13	ms	
				$I_{1\ nom}, I_{SB\ nom}$	5	ms	
$t_{AC\ drop2}$	AC drop without $V_{SB}$ leaving regulation		$I_{1\ nom}, I_{SB\ nom}$		70	ms	
$t_{V1\ holdup}$	Loss of AC to $V_1$ leaving regulation		See chapter <a href="#">INPUT</a>				
$t_{VSB\ holdup}$	Loss of AC to $V_{SB}$ leaving regulation		See chapter <a href="#">INPUT</a>				
$t_{PWOK\_H\ del}$	Outputs in regulation to PWOK_H asserted		100	150	200	ms	
$t_{PWOK\_H\ warn}$	Warning time from de-assertion of PWOK_H to $V_1$ leaving regulation		0.15			ms	
$t_{PWOK\_H\ holdup}$	Loss of AC to PWOK_H de-asserted		$V_{1\ nom\ HL}, I_{1\ nom}, I_{SB\ nom}$	10		ms	
$t_{PWOK\_H\ low}$	Time PWOK_H is kept low after being de-asserted		100			ms	
$t_{PSON\_L\ V1\ on}$	Delay PSON_L active to $V_1$ in regulation		$C_{ext} = 0\ mF$	5	10	20	ms
$t_{PSON\_L\ V1\ off}$	Delay PSON_L de-asserted to $V_1$ disabled		2	3	4	ms	
$t_{PSON\_L\ PWOK\_H}$	Delay PSON_L de-asserted to PWOK_H de-asserted			1	2	ms	
$t_{V1\ off}$	Time $V_1$ is kept off after leaving regulation			1		s	
$t_{VSB\ off}$	Time $V_{SB}$ is kept off after leaving regulation			1		s	

### 8.6 LED INDICATOR

The front-end has one front LED showing the status of the supply. The LED is bi-colored: green and amber, and indicates AC and DC power presence and warning or fault conditions. [Table 1](#) lists the different LED status.

OPERATING CONDITION <sup>9</sup>	LED SIGNALING
No AC or AC Line in UV condition, $V_{SB}$ not present from paralleled power supplies	Off
PSON_L High Hot-Standby Mode	Blinking Green 1 Hz
No AC or AC Line in UV condition, $V_{SB}$ present from paralleled power supplies	
$V_1$ or $V_{SB}$ out of regulation	
Over temperature shutdown	
Output over voltage shutdown ( $V_1$ or $V_{SB}$ )	Solid Amber
Output over current shutdown ( $V_1$ or $V_{SB}$ )	
Fan error (>15%)	
Over temperature warning	
Minor fan regulation error (>5%, <15%)	Blinking Amber 1 Hz
Firmware boot loading in process	Blinking Green 2 Hz
Outputs $V_1$ and $V_{SB}$ in regulation	Solid Green

Table 1. LED Status

<sup>8</sup> At repeated ON-OFF cycles the start-up times may increase by 1s

<sup>9</sup> The order of the criteria in the table corresponds to the testing precedence in the controller



## 9. I<sup>2</sup>C / POWER MANAGEMENT BUS COMMUNICATION

The PET front-end is a communication Slave device only; it never initiates messages on the I<sup>2</sup>C/SMBus by itself. The communication bus voltage and timing is defined in [Table 2](#) and further characterized through:

- The SDA/SCL IOs use 3.3 V logic levels
- External pull-up resistors on SDA/SCL required for correct signal edges
- Full SMBus clock speed of 100 kbps
- Clock stretching limited to 1 ms
- SCL low time-out of >25 ms with recovery within 10 ms
- Recognizes any time Start/Stop bus conditions

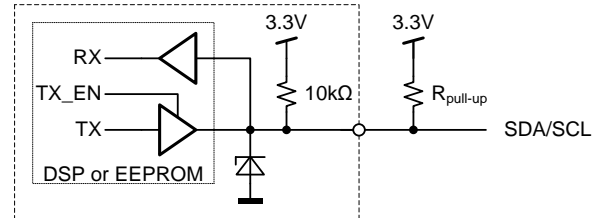

Figure 23. Physical layer of communication interface

Communication to the DSP or the EEPROM will be possible as long as the input AC voltage is provided. If no AC is present, communication to the unit is possible as long as it is connected to a life  $V_{SB}$  output (provided e.g. by the redundant unit). If only  $V_I$  is provided, communication is not possible.

PARAMETER	DESCRIPTION	CONDITION	MIN	MAX	UNIT
<b>SCL / SDA</b>					
$V_L$	Input low voltage		-0.5	1.0	V
$V_H$	Input high voltage		2.3	3.5	V
$V_{Hys}$	Input hysteresis		0.15		V
$V_{OL}$	Output low voltage	3 mA sink current	0	0.4	V
$t_r$	Rise time for SDA and SCL		$20+0.1C_b^1$	300	ns
$t_{of}$	Output fall time $V_{IHmin} \rightarrow V_{ILmax}$	$10 \text{ pF} < C_b^1 < 400 \text{ pF}$	$20+0.1C_b^1$	250	ns
$I_i$	Input current SCL/SDA	$0.1 \text{ VDD} < V_i < 0.9 \text{ VDD}$	-10	10	$\mu\text{A}$
$C_i$	Internal Capacitance for each SCL/SDA			50	pF
$f_{SCL}$	SCL clock frequency		0	100	kHz
$R_{pull-up}$	External pull-up resistor	$f_{SCL} \leq 100 \text{ kHz}$		$1000 \text{ ns} / C_b^1$	$\Omega$
$t_{HDSTA}$	Hold time (repeated) START	$f_{SCL} \leq 100 \text{ kHz}$	4.0		$\mu\text{s}$
$t_{LOW}$	Low period of the SCL clock	$f_{SCL} \leq 100 \text{ kHz}$	4.7		$\mu\text{s}$
$t_{HIGH}$	High period of the SCL clock	$f_{SCL} \leq 100 \text{ kHz}$	4.0		$\mu\text{s}$
$t_{SUSTA}$	Setup time for a repeated START	$f_{SCL} \leq 100 \text{ kHz}$	4.7		$\mu\text{s}$
$t_{HDDAT}$	Data hold time	$f_{SCL} \leq 100 \text{ kHz}$	0	3.45	$\mu\text{s}$
$t_{SUDAT}$	Data setup time	$f_{SCL} \leq 100 \text{ kHz}$	250		ns
$t_{SUSTO}$	Setup time for STOP condition	$f_{SCL} \leq 100 \text{ kHz}$	4.0		$\mu\text{s}$
$t_{BUF}$	Bus free time between STOP and START	$f_{SCL} \leq 100 \text{ kHz}$	5		ms

<sup>1</sup>  $C_b$  = Capacitance of bus line in pF, typically in the range of 10...400 pF

Table 2. I<sup>2</sup>C / SMBus Specification

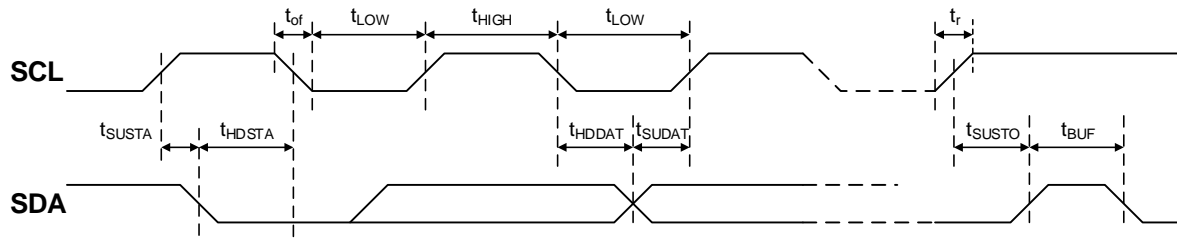

Figure 24. I<sup>2</sup>C / SMBus Timing

**ADDRESS SELECTION**

The address for I<sup>2</sup>C communication can be configured by pulling address input pins A2, A1 and A0 either to GND (Logic Low) or leave them open (Logic High). An internal pull up resistor will cause the A2 / A1 / A0 pin to be in High Level if left open. A fixed addressing offset exists between the Controller and the EEPROM.

A1	A0	I2C Address	
		Controller	EEPROM
0	0	0xB0	0xA0
0	1	0xB2	0xA2
1	0	0xB4	0xA4
1	1	0xB6	0xA6

Table 3. Address and protocol encoding

**9.1 SMBALERT\_L OUTPUT**

The SMBALERT\_L signal indicates that the power supply is experiencing a problem that the system agent should investigate. This is a logical OR of the Shutdown and Warning events. It is asserted (pulled Low) at Shutdown or Warning events such as reaching temperature warning/shutdown threshold of critical component, general failure, over-current, over-voltage, under-voltage or low-speed of a failed fan. This signal may also indicate the power supply is operating in an environment exceeding the specified limits.

The SMBAlert signal is asserted simultaneously with the LED turning to solid amber or blinking amber.

PARAMETER	DESCRIPTION / CONDITION	MIN	NOM	MAX	UNIT
<b>SMB_ALERT_L</b>					
$V_{ext}$	Maximum External Pull up Voltage			12	V
$I_{OH}$	Maximum High Level Leakage Current	No Failure or Warning condition, $V_O = 12\text{ V}$		10	$\mu\text{A}$
$V_{OL}$	Output Low Level Voltage	Failure or Warning condition, $I_{sink} < 4\text{ mA}$		0	0.4
$R_{pull\ up}$	Internal Pull up Resistor to internal 3.3 V			None	
$I_{OL}$	Maximum Sink Current	$V_O < 0.4\text{ V}$		4	mA



## 10. TEMPERATURE AND FAN CONTROL

### 10.1 FAN CONTROL

To achieve best cooling results sufficient airflow through the supply must be ensured. Do not block or obstruct the airflow at the rear of the supply by placing large objects directly at the output connector. The PET2000-NAS446 is provided with a rear to front airflow, which means the air enters through the DC-output of the supply and leaves at the AC-inlet side, as shown in *Figure 25*. The PET2000-NAS446 supply has been designed for horizontal operation.

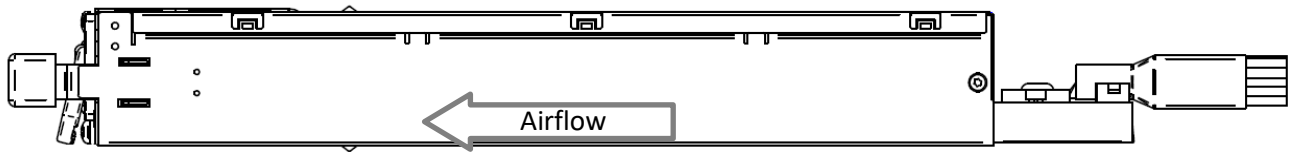

Figure 25. Airflow direction PET2000-NAS446

The fan inside the supply is controlled by a microprocessor. The rpm of the fan is adjusted to ensure optimal supply cooling and is a function of output power. Three different curves are selected based on input voltage and inlet temperature. With standby output loaded the fan speed minimum is limited to ensure enough cooling of circuits providing standby power.

*Figure 26* illustrates the programmed fan curve.

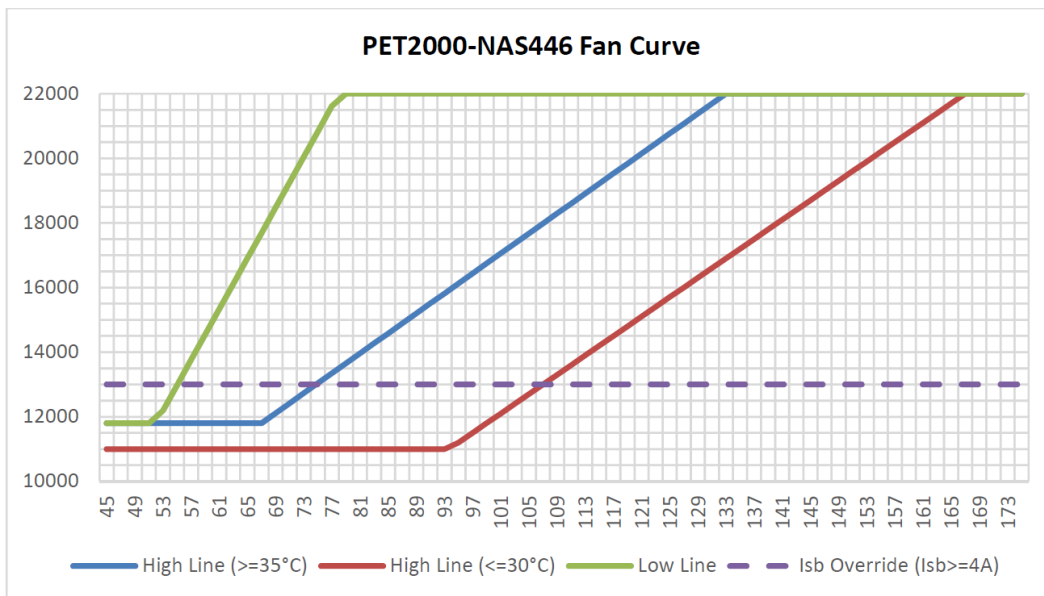

Figure 26. Fan speed vs. main output load

### 10.2 TEMPERATURE MONITOR AND OVER TEMPERATURE PROTECTION

PET2000-NAS446 provides access via I<sup>2</sup>C to the measured temperatures of in total 6 sensors within the power supply, see [Table 4](#). The microprocessor is monitoring these temperatures and if warning threshold of one of these sensors is reached it will set fan to maximum speed. If temperatures continue to rise above shut down threshold the main output  $V_o$  (or  $V_{SB}$  if auxiliary converter is affected) will be disabled. At the same time the warning or fault condition is signaled accordingly through LED, PWOK\_H and SMBALERT\_L.

TEMPERATURE SENSOR	DESCRIPTION / CONDITION	POWER MANAGEMENT BUS REGISTER	WARNING THRESHOLD	SHUTDOWN THRESHOLD
Inlet Air Temperature	Sensor located on control board close to DC end of PSU	8Dh	73°C	78°C
Synchronous Rectifier	Sensor located on secondary side of DC/DC stage	8Eh	95°C	100°C
Primary Heat Sink	Sensor located on primary heat sink	8Fh	87°C	92°C
Output ORing Element	Sensor located close to output	D2h	100°C	105°C
Auxiliary Converter	Sensor located on secondary side on auxiliary rectifier	D3h	80°C	85°C
Bridge Rectifier	Sensor located on heat sink for AC rectifier	D4h	86°C	91°C

Table 4. Temperature sensor location and thresholds

### 10.3 MAXIMUM OUTPUT POWER VERSUS INLET TEMPERATURE FOR SAFETY COMPLIANCY

For safety compliant operation the power supply must not exceed specified operating conditions specified herein. These operating conditions ensure the input AC connector is operated within its ratings.

Between 0°C and 55°C power supply inlet temperature the maximum allowed output power is only depending on AC input connector type chosen, regional usage and the applied nominal input AC voltage. Above 55°C the maximum output power is further reduced with rising temperature. [Figure 27](#) illustrates the maximum current.

Above 55°C the power supply is adjusting the current limit level  $I_{OC\ Slow}$  depending on input voltage range (100-127 VAC or 200-240 VAC) and inlet temperature.

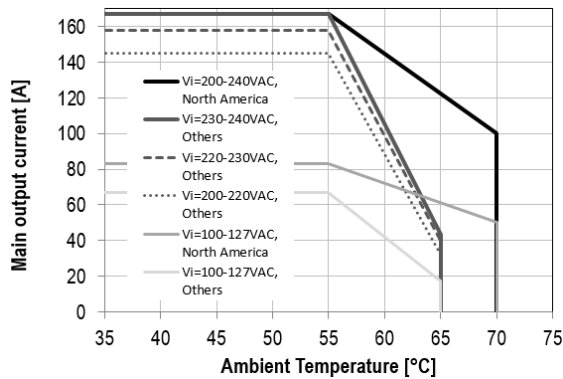

Figure 27. Maximum I1 PET2000-NAS446 (IEC 60320-C14)

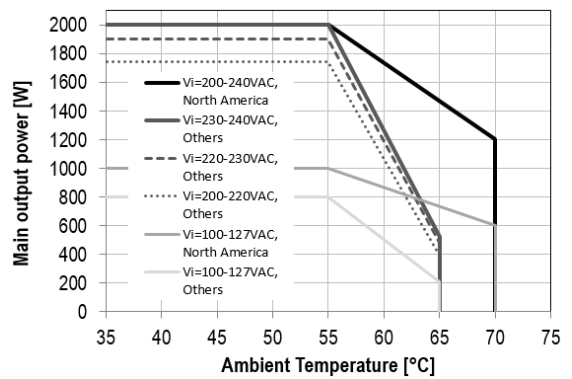

Figure 28. Maximum P1 PET2000-NAS446 (IEC 60320-C14)

## 11. ELECTROMAGNETIC COMPATIBILITY

### 11.1 IMMUNITY

PARAMETER	DESCRIPTION / CONDITION	CRITERION
ESD Contact Discharge	IEC / EN 61000-4-2, $\pm 8$ kV, 25+25 discharges per test point (metallic case, LED, connector body)	A
ESD Air Discharge	IEC / EN 61000-4-2, $\pm 15$ kV, 25+25 discharges per test point (non-metallic user accessible surfaces)	A
Radiated Electromagnetics Filed	IEC / EN 61000-4-3, 10 V/m, 1 kHz/80% Amplitude Modulation, 1 $\mu$ s Pulse Modulation, 10 kHz ... 2 GHz	A
Burst	IEC / EN 61000-4-4, Level 3 AC port $\pm 2$ kV, 1 minute	A
Surge	IEC / EN 61000-4-5, Level 3 Line to Earth: $\pm 2$ kV Line to Line: $\pm 1$ kV	A
RF Conducted Immunity	IEC / EN 61000-4-6, Level 3, 10 Vrms, CW, 0.1 ... 80 MHz	A
Voltage Dips and Interruptions	IEC / EN 61000-4-11 Vi 230VAC / 50 Hz, 90% load, Phase 0°, Dip 100% , duration 10 ms Vi 200VAC / 50 Hz, 70% load, Phase 0°, Dip 30% , duration 500 ms Vi 200VAC / 50 Hz, 100% load, Phase 0°, Dip 20% , duration 10 s	Vi: A, V <sub>SB</sub> : A Vi: A, V <sub>SB</sub> : A Vi: A, V <sub>SB</sub> : A

### 11.2 EMISSION

PARAMETER	DESCRIPTION / CONDITION	CRITERION
Conducted Emission	EN 55022 / CISPR 22: 0.15 ... 30 MHz, QP and AVG, single power supply	Class A 6 dB margin
Radiated Emission	EN 55022 / CISPR 22: 30 MHz ... 1 GHz, QP, single power supply	Class A 6 dB margin
Harmonic Emissions	IEC 61000-3-2, Vi = 115 VAC / 60 Hz & 230 VAC / 50 Hz, 100% Load	Class A
AC Flicker	IEC 61000-3-3, Vi = 230 VAC / 50Hz, 100% Load	Pass
Acoustical Noise	Distance at bystander position, 25°C, 50% Load	65 dBA

## 12. SAFETY / APPROVALS

Maximum electric strength testing is performed in the factory according to IEC/EN 60950, and UL 60950. Input-to-output electric strength tests should not be repeated in the field. Bel Power Solutions will not honor any warranty claims resulting from electric strength field tests.

PARAMETER	DESCRIPTION / CONDITION	NOTES
Agency Approvals	Approved to latest edition of the following standards: UL/CSA60950-1, IEC60950-1 and EN60950-1. NEMKO, CB	Approved
Grade of Insulation	Input (L/N) to chassis (PE) Input (L/N) to output Output to chassis	Basic Reinforced None (Direct connection)
Creepage / Clearance	Primary (L/N) to chassis (PE) Primary to secondary	
Electrical Strength Test	Input to chassis Input to output (tested by manufacturer only)	Min. 2121 VDC 4242 VDC

13. ENVIRONMENTAL

PARAMETER	DESCRIPTION / CONDITION	MIN	NOM	MAX	UNIT
$T_A$ Ambient Temperature	Up to 1'000 m ASL	-5		+40 +55*	°C
	Linear derating from 1'000 to 3'048 m ASL			+35 +45*	°C
$T_{A\ ext}$ Extended Temp. Range	Reduced output power <sup>10</sup> , up to 1'000 m ASL			+55 +70*	°C
	Linear derating from 1'000 to 3'048 m ASL			+50 +60*	
$T_S$ Storage Temperature	Non-operational	-20		+70	°C
Altitude	Operational, above Sea Level	-		3'048	m
	Non-operational, above Sea Level	-		10'600	m
Shock, operational	Half sine, 11ms, 10 shocks per direction,			1	g peak
Shock, non-operational	6 directions			30	g peak
Vibration, sinusoidal, operational	IEC/EN 60068-2-6, sweep 5 to 500 to 5 Hz,			1	g peak
Vibration, sinusoidal, non-operational	1 octave/min, 5 sweep per axis			4	g peak
Vibration, random, non-operational	IEC/EN 60068-2-64, 5 to 500 Hz, 1 hour per axis			0.025	g <sup>2</sup> /Hz

14. RELIABILITY

PARAMETER	DESCRIPTION / CONDITION	MIN	NOM	MAX	UNIT
$MTBF$ Mean time to failure	$T_A = 25^\circ\text{C}$ , according Telcordia SR-332, issue 3, GB, confidence level = 90%	860			kh

15. MECHANICAL

PARAMETER	DESCRIPTION / CONDITION	MIN	NOM	MAX	UNIT
Dimensions	Width		73.5		mm
	Height		40.0		mm
	Depth		331.6		mm
$m$ Weight			1.1		kg

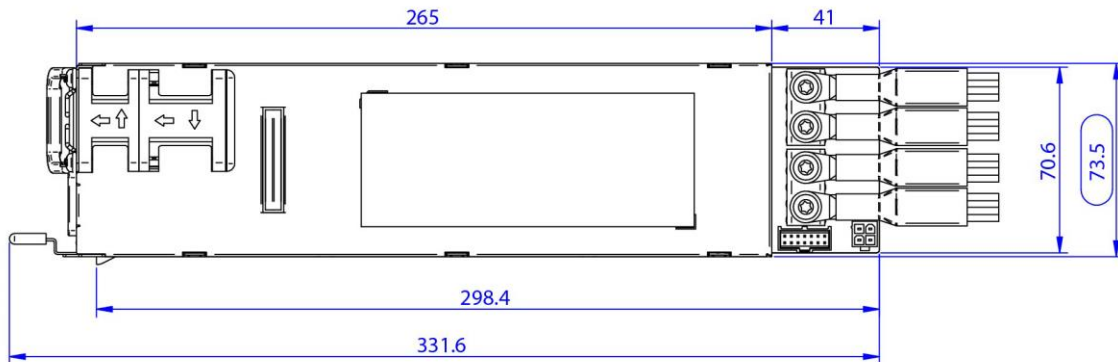

<sup>10</sup> See chapter 10.3

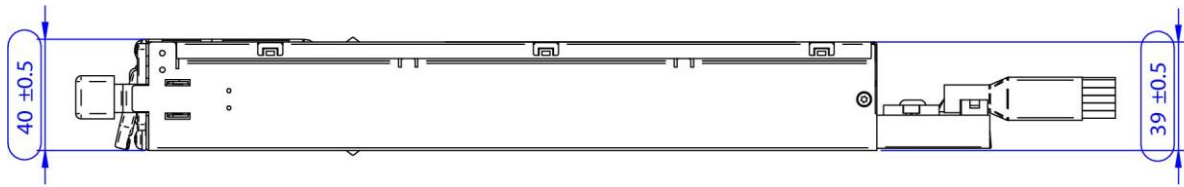

Figure 29. Top and side view

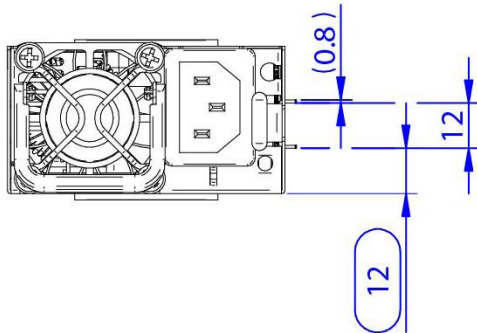

Figure 30. Front view

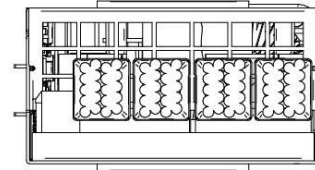

Figure 31. Rear view

### 15.1 OUTPUT CONNECTOR PIN LOCATIONS

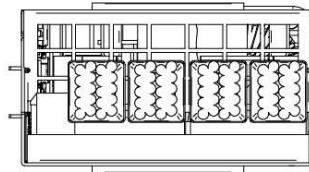

Figure 32. Rear view

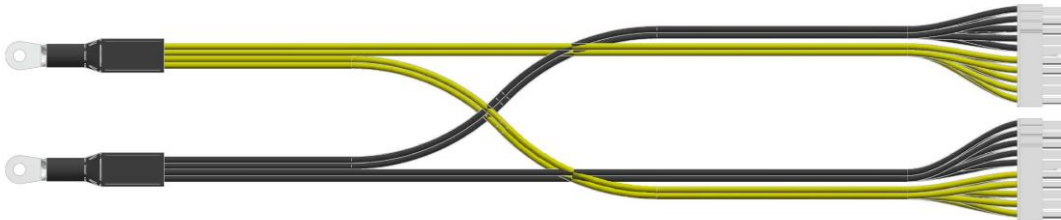

Figure 33. Output wire harness set (length = 450 mm) - two pcs wire harnesses attached on each PSU

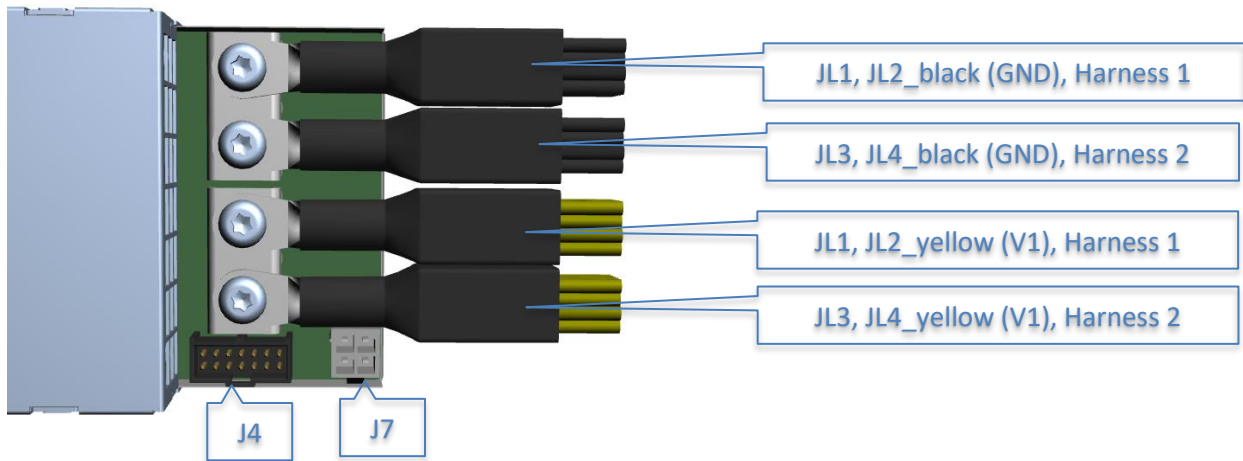

Figure 34. Output connections

## 16. CONNECTORS

PARAMETER	DESCRIPTION / CONDITION	MIN	NOM	MAX	UNIT
AC inlet	PET2000-NAS446 : IEC 60320-C14		10		
AC cord requirement	Wire size	16			AWG
Output connector on wire harness (JL1 to JL4)	Two harnesses. Totally 4 pcs 20 pin connectors (Molex 39-01-2200 or equivalent)		20		PIN
Output connector for signaling (J4)	Male 14-Pin connector (AMTEK 5BH1SDA88-14G05TU-00 or equivalent)		14		PIN
Output connector for external FAN (J7)	Male 4-Pin connector (Molex: 39-31-0040 or equivalent) Female Mating connector (Molex: 15-06-0045 or equivalent)		4		PIN

### 16.1 MATING OUTPUT CONNECTOR SPECIFICATION (on wire two wire harnesses)

PIN	SIGNAL NAME	DESCRIPTION
JL1-1 to JL1-5 JL1-11 to JL1-15 JL2-1 to JL2-5 JL2-11 to JL2-15 JL3-1 to JL3-5 JL3-11 to JL3-15 JL4-1 to JL4-5 JL4-11 to JL4-15	V1 (yellow)	+12 VDC main output
JL1-6 to JL1-10 JL1-16 to JL1-20 JL2-6 to JL2-10 JL2-16 to JL2-20 JL3-6 to JL3-10 JL3-16 to JL3-20 JL4-6 to JL4-10 JL4-16 to JL4-20	GND (black)	Power ground (return)

Table 5. Output pin assignment from Main Wire Harnesses

## 16.2 MATING OUTPUT CONNECTOR SPECIFICATION (Signal connector J4)

PIN	SIGNAL NAME	DESCRIPTION
S1		
S2	GND	Signal ground (return)
S3		
S4	GND	+12 VDC
S5	SDA	I <sup>2</sup> C data signal line
S6	SCL	I <sup>2</sup> C clock signal line
S7	PSON_L	Power supply on input, active-low
S8	PWOK_H	Power OK signal output, active-high
S9	ALARM (SMB_ALERT_L)	PSU ALARM SIGNAL SMB Alert signal output, active-low
S10	PRESENT_L	Power supply seated/connected, active-low
S11	FAN TACHO	External Tacho signal from J7-2 for external fan
S12	FAN PWM	External PWM signal from J7-3 for external fan
S13	A0	I <sup>2</sup> C address selection input
S14	A1	I <sup>2</sup> C address selection input

## 16.3 MATING OUTPUT CONNECTOR SPECIFICATION (FAN supply connector J7)

PIN	SIGNAL NAME	DESCRIPTION
J7-1	GND	Power ground (return)
J7-2	FAN TACHO	Tacho from external fan
J7-3	FAN PWM	PWM for from external fan
J7-4	12V	+12 VDC

For more information on these products consult: [tech.support@psbel.com](mailto:tech.support@psbel.com)

**NUCLEAR AND MEDICAL APPLICATIONS** - Products are not designed or intended for use as critical components in life support systems, equipment used in hazardous environments, or nuclear control systems.

**TECHNICAL REVISIONS** - The appearance of products, including safety agency certifications pictured on labels, may change depending on the date manufactured. Specifications are subject to change without notice.