

## P Series

90 - 192 Watt DC-DC Converters

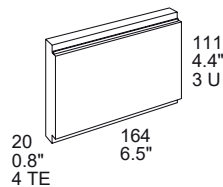

### Features

- RoHS lead-free-solder and lead-solder-exempted products available
- Wide input voltage ranges up to 154 VDC
- 1, 2, 3 or 4 isolated outputs up to 96 V
- Class I equipment
- Compliant with EN 45545 and NF-F-16 (version V114 or later)
- Very high efficiency up to 90%
- Extremely low inrush current, hot-swappable
- Excellent surge and transient protection
- Many output configurations available with flexible load distribution
- Externally adjustable output voltage
- Inhibit primary referenced
- Redundant operation (n+1), sense lines, current sharing option
- Extremely slim case (4 TE, 20 mm), fully enclosed
- Hipot test voltage up to 2.8 kVDC (Version V114 or later)
- All PCBs coated with protective lacquer
- Telecom-compatible input voltage range of DP models according to ETS 300132-2
- Compact PCI-compatible output voltage (xP4720)
- Safety-approved to the latest edition of IEC/EN 62368-1 and UL/CSA 60950-1



### Table of Contents

Description.....	2	Electromagnetic Compatibility (EMC).....	18
Model Selection.....	2	Immunity to Environmental Conditions.....	20
Functional Description.....	6	Mechanical Data.....	21
Electrical Input Data.....	7	Safety and Installation Instructions.....	22
Electrical Output Data.....	9	Description of Options.....	25
Auxiliary Functions.....	15	Accessories.....	26



### Description

These extremely compact DC-DC converters incorporate all necessary input and output filters, signaling and protection features, which are required in the majority of applications. The converters provide important advantages, such as flexible output power through primary-side current limitation, extremely high efficiency, excellent reliability, very low ripple and RFI noise levels, full input-to-output isolation, negligible inrush current, soft start, overtemperature protection and input over- and undervoltage lockout.

The converters are particularly suitable for rugged environments, such as railway applications. They have been designed in accordance with the European railway standards EN 50155 and EN 50121-3-2. All printed circuit boards are coated with a protective lacquer. The converter inputs are protected against surges and transients occurring on the source lines and cover a total operating input voltage range from 16 to 150 VDC with five different model types. The outputs are continuously open- and short-circuit proof.

Full system flexibility and n+1 redundant operating mode are possible due to series or parallel connection capabilities of the outputs under the specified conditions. When several converters (with 3.3 and 5.1 V outputs) are connected in parallel, the T option allows for a single-wire connection between the converters to ensure good current sharing. LEDs at the front panel and an isolated Out-OK signal (option) indicate the status of the converter. Voltage suppressor diodes and an independent second control loop protect the outputs against an internally generated overvoltage.

The converters are designed using planar magnetics transformers and control circuits in hybrid technology. There are always two powertrains fitted to a converter, each consisting either of a regulated single output with synchronous rectifier or of a regulated main output with a tracking second output. The output power may be flexibly distributed among the main and the tracking output of each powertrain. Close magnetic coupling in the transformers and output conductors together with circuit symmetry ensure tight tracking of the auxiliary output. The switching frequency is fixed.

As a modular power supply or as part of a distributed power supply system, the low-profile design significantly reduces the required volume without sacrificing high reliability. The converters are particularly suitable for 19" rack systems occupying 3U/4TE only, but they can also be chassis-mounted by means of four screws. Connector type is H15 (or H15S2 for some single-output models). The fully enclosed black-coated aluminum case acts as heat sink and RFI shield and protects the converter together with the coating of all components against environmental impacts.

### Model Selection

**Note:** Only standard models are listed. Other voltage configurations are possible on request.

Table 1a: Model types BP, CP

Output 1, 4			Output 2, 3			Efficiency <sup>2</sup> , Operating input voltage range				Options
V <sub>o nom</sub> [V]	P <sub>o nom</sub> [W]	P <sub>o max</sub> [W]	V <sub>o nom</sub> [V]	P <sub>o nom</sub> [W]	P <sub>o max</sub> [W]	η <sup>2</sup> [%]	V <sub>i min</sub> - V <sub>i max</sub> <sup>4</sup> 16 - 36 V	η <sup>2</sup> [%]	V <sub>i min</sub> - V <sub>i max</sub> <sup>4</sup> 33.6 - 75 V	
3.3	92	132	-	-	-	84 <sup>8</sup>	BP1101-9RG	84 <sup>8</sup>	CP1101-9RG	-7, D, T <sup>5</sup> , K <sup>8</sup> , B0, B1, B3, non-G
5.1	122	183	-	-	-	87 <sup>8</sup>	BP1001-9RG	88 <sup>8</sup>	CP1001-9RG	
12	120	192	-	-	-	87.5	BP1301-9RG	88.5	CP1301-9RG	
15	120	192	-	-	-	87.5	BP1501-9RG	88.5	CP1501-9RG	
24	120	192	-	-	-	88	BP1601-9RG	89	CP1601-9RG	
3.3	46	66	5.1	61	91	86	BP2101-9RG	86	CP2101-9RG	-7, D, T <sup>6</sup> , B0, B1, B3, non-G
5.1	61	91	5.1	61	91	87	BP2001-9RG	88	CP2001-9RG	
5.1	61	91	12	60	96	87	BP2020-9RG	88	CP2020-9RG	
12	60	96	12	60	96	87.5	BP2320-9RG	88.5	CP2320-9RG	
15	60	96	15	60	96	87.5	BP2540-9RG	88.5	CP2540-9RG	
24	60	96	24	60	96	88	BP2660-9RG	89	CP2660-9RG	
5.1	61	91	12, 12 <sup>3</sup>	60 <sup>1</sup>	96 <sup>1</sup>	87	BP3020-9RG	89	CP3020-9RG	-7, non-G
5.1	61	91	15, 15 <sup>3</sup>	60 <sup>1</sup>	96 <sup>1</sup>	87.5	BP3040-9RG	88.5	CP3040-9RG	
5.1	61	91	24, 24 <sup>3</sup>	60 <sup>1</sup>	96 <sup>1</sup>	87.5	BP3060-9RG	88.5	CP3060-9RG	
12	60	96	15, 15 <sup>3</sup>	60 <sup>1</sup>	96 <sup>1</sup>	87	BP3340-9RG	-	-	
24	60	96	5.1, 5.1 <sup>3</sup>	51 <sup>1</sup>	82 <sup>1</sup>	-	-	87	CP3601-9RG	
5.1, 3.3 <sup>7</sup>	30	50	12, 12 <sup>3</sup>	60 <sup>1</sup>	96 <sup>1</sup>	85	BP4720-9RG	-	CP4720-9RG	-7, D, B0, B1, B3, non-G
5.1, 5.1 <sup>3</sup>	51 <sup>1</sup>	82 <sup>1</sup>	15, 15 <sup>3</sup>	60 <sup>1</sup>	96 <sup>1</sup>	86	BP4040-9RG	-	CP4040-9RG	
12, 12 <sup>3</sup>	60 <sup>1</sup>	96 <sup>1</sup>	12, 12 <sup>3</sup>	60 <sup>1</sup>	96 <sup>1</sup>	87.5	BP4320-9RG	88.5	CP4320-9RG	
15, 15 <sup>3</sup>	60 <sup>1</sup>	96 <sup>1</sup>	15, 15 <sup>3</sup>	60 <sup>1</sup>	96 <sup>1</sup>	87.5	BP4540-9RG	88.5	CP4540-9RG	
24, 24 <sup>3</sup>	60 <sup>1</sup>	96 <sup>1</sup>	24, 24 <sup>3</sup>	60 <sup>1</sup>	96 <sup>1</sup>	88	BP4660-9RG	89	CP4660-9RG	

<sup>1</sup> The power of both outputs shall in sum not exceed the total power for the specified ambient temperature.  
<sup>2</sup> Min efficiency at V<sub>i nom</sub>, P<sub>o nom</sub>, T<sub>A</sub> = 25 °C. Typical values are approx. 2% better.  
<sup>3</sup> Isolated tracking output (±5% V<sub>o nom</sub>, if each output is loaded with ≥ 5% of P<sub>o nom</sub>). Parallel or series configuration is possible.  
<sup>4</sup> Short deviations below V<sub>i min</sub> and beyond V<sub>i max</sub> according to EN 50155 possible; see table 2a.  
<sup>5</sup> Only available for models with 5.1 or 3.3 V output.  
<sup>6</sup> Option T is only available for outputs with 5.1 or 3.3 V. Opt. T excludes opt. R; refer to table 13, pin allocations  
<sup>7</sup> Outputs 5.1 and 3.3 V have a common return. Nominal values: 5.1 V / 4 A, 3.3 V / 3 A. Max. values: 5.1 V / 6.5 A, 3.3 V / 5 A.  
<sup>8</sup> Option K only for xP1101 and xP1001: H15 standard connector. Models without option K exhibit a better efficiency: xP1101 is approx 2% better, xP1001 approx 1% better than the models with option K.

NFND: Not for new designs. Preferred for new designs



Asia-Pacific +86 755 298 85888 EMEA +353 61 531 820 North America +1 866 513 2839

powersupport@belf.com  
belfuse.com

Table 1b: Model types DP, EP

Output 1, 4			Output 2, 3			Efficiency <sup>2</sup> , Operating input voltage range			Options	
V <sub>o nom</sub> [V]	P <sub>o nom</sub> [W]	P <sub>o max</sub> [W]	V <sub>o nom</sub> [V]	P <sub>o nom</sub> [W]	P <sub>o max</sub> [W]	η <sup>2</sup> [%]	V <sub>i min</sub> - V <sub>i max</sub> <sup>4</sup> 40 - 100.8 V	η <sup>2</sup> [%]		V <sub>i min</sub> - V <sub>i max</sub> <sup>4</sup> 67.2 - 150 V
3.3	92	132	-	-	-	84 <sup>8</sup>	DP1101-9RG	83.5 <sup>8</sup>	EP1101-9RG	-7, D, T <sup>5</sup> , K <sup>8</sup> , B0, B1, B3, non-G
5.1	122	183	-	-	-	88 <sup>8</sup>	DP1001-9RG	87.5 <sup>8</sup>	EP1001-9RG	
12	120	192	-	-	-	88	DP1301-9RG	87.5	EP1301-9RG	
15	120	192	-	-	-	88	DP1501-9RG	87	EP1501-9RG	
24	120	192	-	-	-	88	DP1601-9RG	87.5	EP1601-9RG	
3.3	46	66	5.1	61	91	86	DP2101-9RG	86	EP2101-9RG	-7, D, T <sup>6</sup> , B0, B1, B3, non-G
5.1	61	91	5.1	61	91	88	DP2001-9RG	87.5	EP2001-9RG	
5.1	61	91	12	60	96	88	DP2020-9RG	87.5	EP2020-9RG	
12	60	96	12	60	96	88	DP2320-9RG	87.5	EP2320-9RG	
15	60	96	15	60	96	88	DP2540-9RG	87	EP2540-9RG	
24	60	96	24	60	96	88	DP2660-9RG	87.5	EP2660-9RG	
5.1	61	91	12, 12 <sup>3</sup>	60 <sup>1</sup>	96 <sup>1</sup>	87.5	DP3020-9RG	87.5	EP3020-9RG	-7, D, B0, B1, B3, non-G
5.1	61	91	15, 15 <sup>3</sup>	60 <sup>1</sup>	96 <sup>1</sup>	88	DP3040-9RG	88	EP3040-9RG	
5.1	61	91	24, 24 <sup>3</sup>	60 <sup>1</sup>	96 <sup>1</sup>	88	DP3060-9RG	88	EP3060-9RG	
5.1, 3.3 <sup>7</sup>	30	50	12, 12 <sup>3</sup>	60 <sup>1</sup>	96 <sup>1</sup>	85	DP4720-9RG	-	EP4720-9RG	-7, D, B0, B1, B3, non-G
12, 12 <sup>3</sup>	60 <sup>1</sup>	96 <sup>1</sup>	12, 12 <sup>3</sup>	60 <sup>1</sup>	96 <sup>1</sup>	88	DP4320-9RG	87.5	EP4320-9RG	
15, 15 <sup>3</sup>	60 <sup>1</sup>	96 <sup>1</sup>	15, 15 <sup>3</sup>	60 <sup>1</sup>	96 <sup>1</sup>	88	DP4540-9RG	87	EP4540-9RG	
24, 24 <sup>3</sup>	60 <sup>1</sup>	96 <sup>1</sup>	24, 24 <sup>3</sup>	60 <sup>1</sup>	96 <sup>1</sup>	88	DP4660-9RG	87.5	EP4660-9RG	

Table 1c: Model types GP

Output 1, 4			Output 2, 3			Efficiency <sup>2</sup> , Operating input voltage range		Options
V <sub>o nom</sub> [V]	P <sub>o nom</sub> [W]	P <sub>o max</sub> [W]	V <sub>o nom</sub> [V]	P <sub>o nom</sub> [W]	P <sub>o max</sub> [W]	η <sup>2</sup> [%]	V <sub>i min</sub> - V <sub>i max</sub> <sup>4</sup> 21.6 - 50.4 V	
3.3	92	132	-	-	-	84 <sup>8</sup>	GP1101-9RG	-7, D, T <sup>5</sup> , K <sup>8</sup> , B0, B1, B3, non-G
5.1	122	183	-	-	-	88 <sup>8</sup>	GP1001-9RG	
12	120	192	-	-	-	88	GP1301-9RG	
15	120	192	-	-	-	88.5	GP1501-9RG	
24	120	192	-	-	-	88	GP1601-9RG	
3.3	46	66	5.1	61	91	86	GP2101-9RG	-7, D, T <sup>6</sup> , B0, B1, B3, non-G
5.1	61	91	5.1	61	91	88	GP2001-9RG	
5.1	61	91	12	60	96	87.5	GP2020-9RG	
12	60	96	12	60	96	88	GP2320-9RG	
15	60	96	15	60	96	88.5	GP2540-9RG	
24	60	96	24	60	96	88	GP2660-9RG	
5.1	61	91	12, 12 <sup>3</sup>	60 <sup>1</sup>	96 <sup>1</sup>	87.5	GP3020-9RG	-7, D, B0, B1, B3, non-G
5.1	61	91	15, 15 <sup>3</sup>	60 <sup>1</sup>	96 <sup>1</sup>	88.5	GP3040-9RG	
5.1	61	91	24, 24 <sup>3</sup>	60 <sup>1</sup>	96 <sup>1</sup>	88.5	GP3060-9RG	
5.1, 3.3 <sup>7</sup>	30	50	12, 12 <sup>3</sup>	60 <sup>1</sup>	96 <sup>1</sup>	-	GP4720-9RG	-7, D, B0, B1, B3, non-G
12, 12 <sup>3</sup>	60 <sup>1</sup>	96 <sup>1</sup>	12, 12 <sup>3</sup>	60 <sup>1</sup>	96 <sup>1</sup>	88	GP4320-9RG	
15, 15 <sup>3</sup>	60 <sup>1</sup>	96 <sup>1</sup>	15, 15 <sup>3</sup>	60 <sup>1</sup>	96 <sup>1</sup>	88.5	GP4540-9RG	
24, 24 <sup>3</sup>	60 <sup>1</sup>	96 <sup>1</sup>	24, 24 <sup>3</sup>	60 <sup>1</sup>	96 <sup>1</sup>	88	GP4660-9RG	

<sup>1</sup> The power of both outputs may in sum not exceed the total power for the specified ambient temperature.

<sup>2</sup> Min efficiency at V<sub>i nom</sub>, P<sub>o nom</sub>, T<sub>A</sub> = 25 °C. Typical values are approx. 2% better.

<sup>3</sup> Isolated tracking output (±5% V<sub>o nom</sub>, if each output is loaded with ≥5% of P<sub>o nom</sub>). Parallel or series configuration possible

<sup>4</sup> Short deviations below V<sub>i min</sub> and beyond V<sub>i max</sub> according to EN 50155 possible; see table 2.

<sup>5</sup> Only available for models with 5.1 or 3.3 V output

<sup>6</sup> Option T is only available for outputs with 5.1 or 3.3 V. Opt. T excludes opt. R; refer to table 13, pin allocations

<sup>7</sup> Outputs 5.1 and 3.3 V have a common return. Nominal values: 5.1 V / 4 A, 3.3 V / 3 A. Max. values: 5.1 V / 6.5 A, 3.3 V / 5 A.

<sup>8</sup> H15 standard connector for xP1101 and xP1001 models; without option K, the η value for xP1101 is approx 2% better and for xP1001 approx 1% better than for models with option K.

  NFND: Not for new designs.

  Preferred for new designs



### Part Number Description

	C	P	3	0	20	-9	D	T	B1	G
Input voltage $V_{i\text{nom}}$ :										
24 VDC .....										B
48 VDC .....										C
72 VDC .....										D
110 VDC .....										E
36 VDC .....										G
Series .....		P								
Number of outputs:										
Single output (160 mm case) <sup>4</sup> .....										1
Double output (160 mm case) <sup>4</sup> .....										2
Triple output (160 mm case) <sup>4</sup> .....										3
Quadruple output (160 mm case) <sup>4</sup> .....										4
Nominal voltage output 1/output 4, $V_{o1/4\text{nom}}$ :										
3.3 V .....										1
5.1 V .....										0
12 V .....										3
15 V .....										5
24 V .....										6
other voltages <sup>1</sup> .....										7, 8
Other specifications and additional features <sup>1</sup> .....										01, ...99
Nominal voltage output 2 / output 3, $V_{o2/3\text{nom}}$ :										
5.1 V .....										01
3.3 V .....										10
12 V .....										20
15 V .....										40
24 V .....										60
other voltages and features <sup>1</sup> .....										80, ... 99
Operational ambient temperature range $T_A$ :										
-40 to 71 °C .....										-9
-25 to 71 °C (option) .....										-7
others <sup>1</sup> .....										0, -6
Output voltage adjust (auxiliary function) .....										R
Options:										
Out OK output .....										D
Current sharing .....										T <sup>2</sup>
H15 standard connector .....										K <sup>3</sup>
Heatsink .....										B0, B1, B3
RoHS compliant for all 6 substances .....										G

<sup>1</sup> Customer-specific models.  
<sup>2</sup> Only available for 3.3 V and 5 V outputs. Option T excludes option R, except for single-output models; refer to table 1.  
<sup>3</sup> For single-output models with 3.3 V or 5 V output  
<sup>4</sup> Models with 220 mm case length. Just add 5000 to the standard model number, e.g. EP8060-9RG.

**Note:** The sequence of options must follow the order above. This description is not intended for creating new part numbers.

**Example:** CP3020-9DTB1G: DC-DC converter, input voltage 33.6 to 75V, 1 regulated output providing 5.1 V, 2<sup>nd</sup> powertrain with 2 × 12 V, equipped with option D, option T for output 1, heatsink, ambient temperature -40 to 71 °C, RoHS.

**Note:** All models exhibit the following auxiliary functions, which are not shown in the type designation: input and output filters, primary referenced inhibit, sense lines (single-, double- and triple-output models only) and LED indicators.

### Product Marking

Basic type designation, safety approval and recognition marks, CE mark, warnings, pin allocation, patents, company logo, specific type designation, input voltage range, nominal output voltages and output currents, degree of protection, batch no., serial no. and data code including production site, modification status and date of production. Identification of LEDs.



Asia-Pacific +86 755 298 85888 EMEA +353 61 531 820 North America +1 866 513 2839  
 powersupport@belfuse.com  
[belfuse.com](http://belfuse.com)



### Output Configuration

The P Series allows high flexibility in output configuration to cover almost every individual requirement, by simply wiring outputs in parallel, in series, or in independent configuration, as shown in the following diagrams.

Parallel or serial operation of several converters with equal output voltage is possible, however it is not advantageous to connect converters in parallel without measures to provide reasonable current sharing. Choose suitable single-output models, if available.

**Note:** Unused tracking outputs should be connected parallel to the respective regulated output.

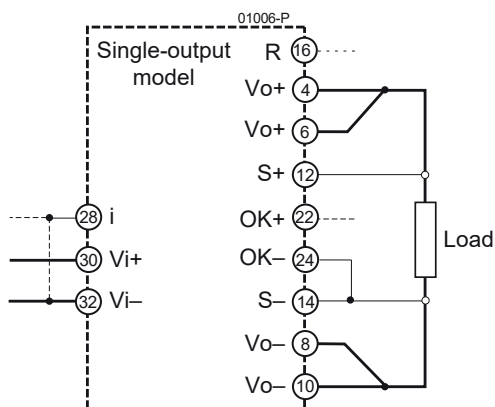

Fig. 1  
Standard configuration (single-output model)

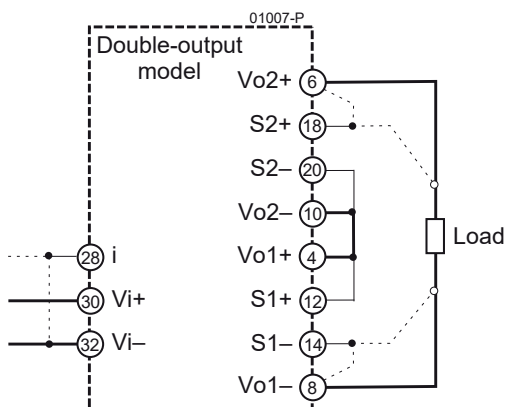

Fig. 2  
Series output configuration of a double-output model. The second output is fully regulated.

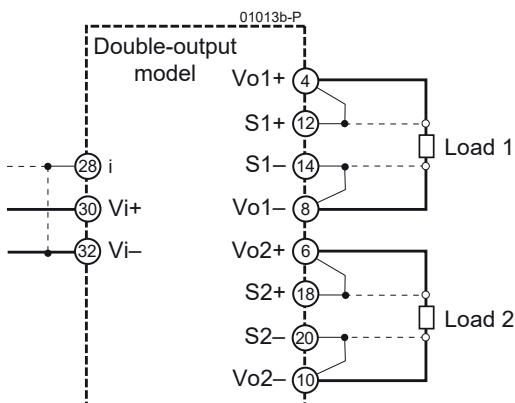

Fig. 3  
Independent double-output configuration. Both outputs are fully regulated

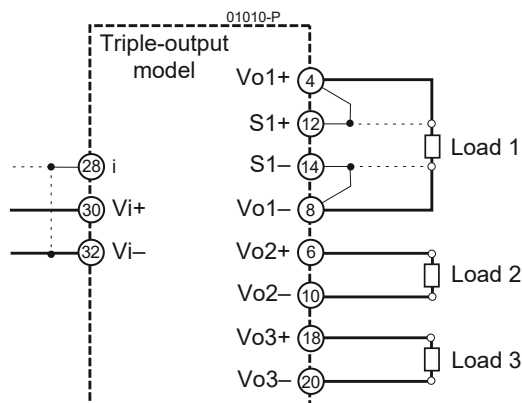

Fig. 4  
Independent triple-output configuration. Output 3 is tracking

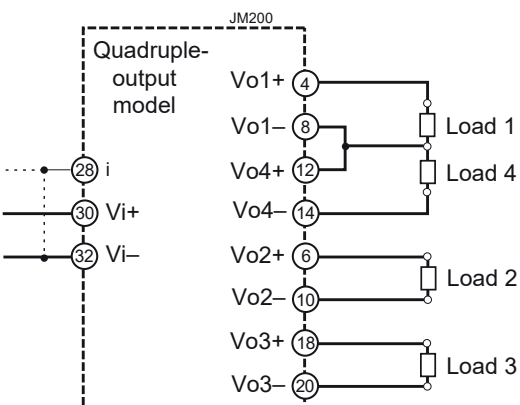

Fig. 5  
Common ground configuration of output 1 with 4 and independent configuration of output 2 and 3

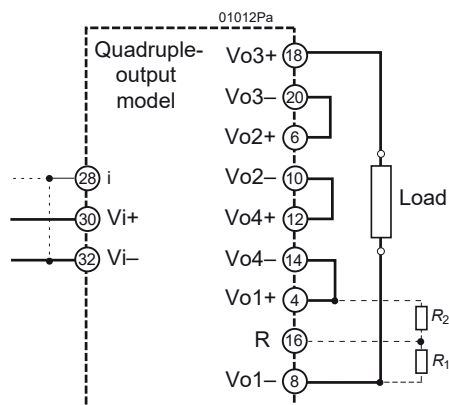

Fig. 6  
Series configuration of all outputs ( $V_o = 96\text{ V}$  for xP4660). The R-input influences only outputs 1 and 4. For the values of R1 and R2, see Output Voltage Adjust.



### Functional Description

The power supplies are equipped with two independent flight-forward converters, switching 180° phase-shifted to minimize the ripple current at the input. They use primary and secondary control circuits in hybrid technology. The two converters, called "powertrains" (PT). Each powertrain generates either a single output with synchronous rectifier or two isolated outputs, one fully regulated and the other one tracking (semi-regulated), thus providing up to four output voltages. In some models, both outputs of a powertrain are internally connected in parallel.

The highly efficient input filter together with very low input capacitance results in a very low and short inrush current. After the isolating transformer and rectification, the output filter reduces ripple and noise to a minimum without affecting the dynamic response. Outputs 3 and 4, if available, are tracking (semi-regulated) and exhibit due to the close magnetic coupling of the common transformer and output inductor together with the circuit symmetry a close voltage regulation. A current limitation circuit is located on the primary side of each powertrain, limiting the total output current of that powertrain in overload conditions. This allows for flexible power operation of the outputs from each powertrain. All outputs can either be connected in series or in parallel; see *Electrical Output Data*.

An auxiliary converter provides the bias voltages for the primary and secondary referenced control logic and the option circuits. An oscillator generates a clock pulse of  $307 \pm 1\%$  kHz, which is fed to the control logic of each powertrain. The pulse width modulation and the magnetic feedback are provided by special ASICs. The converter is only enabled, if the input voltage is within the operating voltage range.

Double-output powertrains are equipped with an independent monitor sensing the output voltage of the tracking output. It influences the control logic in order to reduce via the pulse width the voltages of both outputs. In addition, the tracking outputs are protected by a suppressor diode.

Outputs of single-output powertrains are also protected by a suppressor diode.

The temperature of the heat sink is monitored and causes the converter to disable the outputs. After the temperature dropped, the converter automatically resumes.

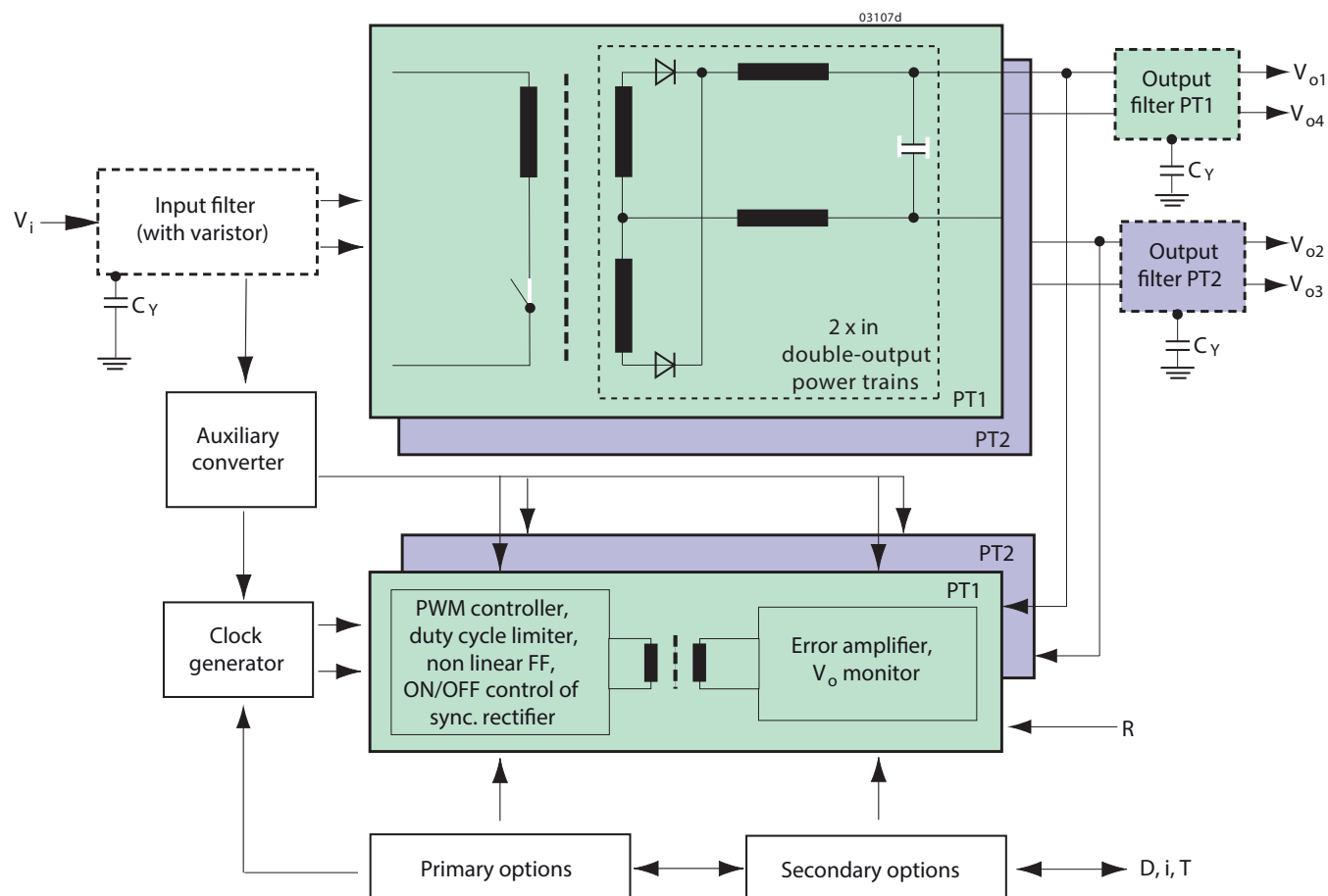

Fig. 7  
Block diagram. Powertrains PT1 and PT2 have isolated outputs.  
Pin allocation see table 13

# P Series

## 90 - 192 W DC-DC Converters



### Electrical Input Data

General Conditions:

- $T_A = 25^\circ\text{C}$ , unless  $T_C$  is specified
- Sense lines connected directly at the connector, inhibit (pin 28) connected to Vi– (pin 32)
- R input open

Table 2a: Input data

Model			BP			GP			CP			Unit
Characteristics		Conditions	min	typ	max	min	typ	max	min	typ	max	
$V_i$	Operating input voltage continuous	$I_o = 0 - I_{o\max}$ $T_{C\min} - T_{C\max}$	16		36	21.6		50.4	33.6		75	V
$V_{i\text{nom}}$	Nominal input voltage			24			36		48			
$V_{i2s}$	For $\leq 2$ s	Without lockout	14.4		40	20		52	28.8		81	
$V_{i\text{abs}}$	For $\leq 3$ s	Without damage	0		50	0		63	0		100	
$I_i$	Typical input current <sup>1</sup>	$V_{i\text{nom}}, I_{o\text{nom}}$		5.6			3.7			2.8		A
$P_{i0}$	No-load input power <sup>1</sup>	$V_{i\min} - V_{i\max}, I_o = 0$	4		6.5	4		6.5	5		10	W
$P_{i\text{inh}}$	Idle input power <sup>1,4</sup>		1		1.5	1		1.5	1		1.5	
$C_i$	Input capacitance			220			220			107		$\mu\text{F}$
$I_{\text{inr p}}$	Peak inrush current <sup>2</sup>	$V_{i\max}, I_{o\max}$		61			64			66		A
$t_{\text{inr rise}}$	Rise time inrush				50			32			30	
$t_r$	Rise time inhibit <sup>3</sup>	$I_{o\max} - V_{i\text{nom}}$		5			5			5		ms
$t_f$	Fall time inhibit <sup>3</sup>				5			5			5	
$t_{\text{on}}$	Start-up time <sup>3</sup>	$0 \rightarrow V_{i\min}, I_{o\text{nom}}$		110			150			300		

Table 2b: Input data

Model			DP <sup>2</sup>			EP			Unit
Characteristics		Conditions	min	typ	max	min	typ	max	
$V_i$	Operating input voltage continuous	$I_o = 0 - I_{o\max}$ $T_{C\min} - T_{C\max}$	40 <sup>2</sup>		100.8	67.2		150	V
$V_{i\text{nom}}$	Nominal input voltage			72			110		
$V_{i2s}$	For $\leq 2$ s	Without lockout	38		100.8	66 <sup>5</sup>		154	
$V_{i\text{abs}}$	For $\leq 3$ s	Without damage	0		125	0		200	
$I_i$	Typical input current <sup>1</sup>	$V_{i\text{nom}}, I_{o\text{nom}}$		1.9			1.2		A
$P_{i0}$	No-load input power <sup>1</sup>	$V_{i\min} - V_{i\max}, I_o = 0$	5		11	5		12	W
$P_{i\text{inh}}$	Idle input power <sup>1,4</sup>		1		1.7	1.1		1.7	
$C_i$	Input capacitance			15			15		$\mu\text{F}$
$I_{\text{inr p}}$	Peak inrush current <sup>2</sup>	$V_{i\max}, I_{o\max}$		57			65		A
$t_{\text{inr rise}}$	Rise time inrush				20			20	
$t_r$	Rise time inhibit <sup>3</sup>	$I_{o\max} - V_{i\text{nom}}$		5			5		ms
$t_f$	Fall time inhibit <sup>3</sup>				5			6	
$t_{\text{on}}$	Start-up time <sup>3</sup>	$0 \rightarrow V_{i\min}, I_{o\text{nom}}$		200			200		

<sup>1</sup> Typical values depending on model

<sup>2</sup> According to ETS 300132-2

<sup>3</sup> See fig. 18

<sup>4</sup> Converter inhibited

<sup>5</sup>  $V_{i\min} = 57.6$  V for 0.1 s without lockout (operation with 96 V battery)

## Input Fuse and Reverse Polarity

A fuse mounted inside the converter protects against further damage in case of a failure. The fuse is not user-accessible. Reverse polarity at the input will cause the fuse to blow.

Table 3: Fuse specification

Model	Fuse type	Rating	Reference
BP	very fast blow	2× 10 A, 125 V	Littelfuse Pico 251
GP	very fast blow	2× 10 A, 125 V	Littelfuse Pico 251
CP	very fast blow	10 A, 125 V	Littelfuse Pico 251
DP	very fast blow	7 A, 125 V	Littelfuse Pico 251
EP	very fast blow	5 A, 250 V	Littelfuse Pico 263

## Input Transient Protection

A VDR (Voltage Dependent Resistor), the input fuse, and a symmetrical input filter form an effective protection against input transients, which typically occur in most installations, but especially in battery-driven mobile applications.

Nominal battery voltages in use are: 24, 36, 48, 72, 96, and 110 V. In most cases each nominal value is specified in a tolerance of -30% to +25%, with short excursions to ±40% or even more.

In some applications, surges according to RIA12 are specified in addition to those defined in IEC 60571-1 or EN 50155. The power supply must not switch off during these surges, and since their energy can practically not be absorbed, an extremely wide input range is required. The P Series input ranges have been designed and tested to meet these requirements; see *Electromagnetic Immunity*.

## Input Under-/Overvoltage Lockout

When the input voltage is below  $V_{i2s\min}$  or exceeds  $V_{i2s\max}$ , an internally generated inhibit signal disables the converter. It automatically recovers, when  $V_i$  is back in range.

## Inrush Current

The inherent inrush current value is lower than specified in the standard ETS 300132-2. The converters operate with relatively small input capacitance  $C_i$  resulting in low inrush current of short duration. As a result, in a power-bus system the units can be hot plugged-in or disconnected causing negligible disturbances at the input side.

## Input Stability with Long Supply Lines

If a converter is connected to the power source by long supply lines exhibiting a considerable inductance  $L_{\text{ext}}$ , an additional external capacitor  $C_{\text{ext}}$  connected across the input pins improves the stability and prevents oscillations.

Actually, a P Series converter with its load acts as negative resistor  $r_i$ , because the input current  $I_i$  rises, when the input voltage  $V_i$  decreases. It tends to oscillate with a resonant frequency determined by the line inductance  $L_{\text{ext}}$  and the input capacitance  $C_i + C_{\text{ext}}$  damped by the resistor  $R_{\text{ext}}$ . The whole system is not linear at all and eludes a simple calculation. One basic condition is given by the formula:

$$C_i + C_{\text{ext}} > \frac{L_{\text{ext}} \cdot P_{o\max}}{R_{\text{ext}} \cdot V_{i\min}^2} \quad \left( r_i = \frac{dV_i}{dI_i} \right)$$

$R_{\text{ext}}$  is the series resistor of the voltage source including the supply lines. If this condition is not fulfilled, the converter may not reach stable operating conditions. Worst case conditions are a lowest  $V_i$  and at highest output power  $P_o$ .

Low inductance  $L_{\text{ext}}$  of the supply lines and an additional capacitor  $C_{\text{ext}}$  are helpful. Recommended values for  $C_{\text{ext}}$  are given in table 4, which should allow for stable operation up to an input inductance of 2 mH.  $C_i$  is specified in table 2.

Table 4: Recommended values for  $C_{\text{ext}}$

Model	Capacitance	Voltage
BP	1500 $\mu\text{F}$	40 V
GP	1000 $\mu\text{F}$	63 V
CP	470 $\mu\text{F}$	100 V
DP	220 $\mu\text{F}$	125 V
EP	100 $\mu\text{F}$	200 V

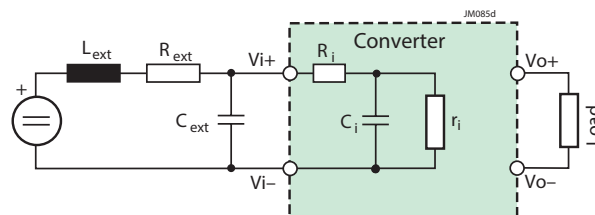

Fig. 8  
Input configuration

## Electrical Output Data

General Conditions:

- $T_A = 25^\circ\text{C}$ , unless  $T_C$  is specified.
- Sense lines connected directly at the connector, inhibit (28) connected to Vi– (32).
- R input not connected

Table 5a: Output data for single-output powertrains

Output		Single-output powertrain	3.3 V			5.1 V			12 V			Unit
Characteristics		Conditions	min	typ	max	min	typ	max	min	typ	max	
$V_o$	Output voltage <sup>1</sup>	$V_{i\text{nom}}, I_{o\text{nom}}$	3.28	3.3	3.32	5.07	5.1	5.13	11.94	12	12.06	V
$V_{ow}$	Worst case output voltage	$V_{i\text{min}} - V_{i\text{max}}$ $T_{C\text{min}} - T_{C\text{max}}$ $(0.02 - 1) I_{o\text{nom}}$	3.24		3.35	5.02		5.18	11.82		12.18	
$V_{oP}$	Overvoltage protection <sup>2</sup>		4.1	4.8		6.45	6.8	7.14	14.3	15	15.8	
$I_{o\text{nom}}$	Nominal output current			14			12			5		A
$I_{o\text{max}}$	Max. output current	$V_{i\text{min}} - V_{i\text{max}}$		20			18			8		
$I_{oL}$	Output current limit <sup>3</sup>	$T_{C\text{min}} - T_{C\text{max}}$	20.5	22	25	18.9	19.8	22.5	8.4	8.8	10	
$V_o$	Output noise <sup>4</sup>	Switch. frequency	$V_{i\text{nom}}, I_{o\text{max}}$			5			15			mV <sub>pp</sub>
		Total incl. spikes	BW = 20 MHz			20			30			
$V_{od}$	Dynamic load regulation	Voltage deviation	$V_{i\text{nom}}$			0.7			0.8			V
$t_d$ <sup>5</sup>		Recovery time	$I_{o\text{max}} \leftrightarrow \frac{1}{2} I_{o\text{max}}$			0.4			0.3			ms
$V_{otr}$	Output voltage trim range (via R-input)	$1.1 V_{i\text{min}} - V_{i\text{max}}$ $(0.1 - 1) I_{o\text{max}}$	1.79		3.63	2.75		5.61	6.5		13.2	V
$\alpha_{vo}$	Temperature coefficient of $V_o$	$\frac{I_{o\text{nom}}}{T_{C\text{min}} - T_{C\text{max}}}$	±0.02			±0.02			±0.02			%/K

Table 5b: Output data for single-output powertrains. General conditions as in table 5a

Output		Single-output powertrain	15 V			24 V			Unit
Characteristics		Conditions	min	typ	max	min	typ	max	
$V_o$	Output voltage <sup>1</sup>	$V_{i\text{nom}}, I_{o\text{nom}}$	14.93	15	15.08	23.88	24	24.12	V
$V_{ow}$	Worst case output voltage	$V_{i\text{min}} - V_{i\text{max}}$ $T_{C\text{min}} - T_{C\text{max}}$ $(0.02 - 1) I_{o\text{nom}}$	14.78		15.23	23.64		24.36	
$V_{oP}$	Overvoltage protection <sup>2</sup>		17.1	18	18.9	28.5	30	31.5	
$I_{o\text{nom}}$	Nominal output current			4			2.5		A
$I_{o\text{max}}$	Max. output current	$V_{i\text{min}} - V_{i\text{max}}$		6.4			4		
$I_{oL}$	Output current limit <sup>3</sup>	$T_{C\text{min}} - T_{C\text{max}}$	6.8	7.2	8.2	4.2	4.4	5.0	
$V_o$	Output noise <sup>4</sup>	Switch. frequency	$V_{i\text{nom}}, I_{o\text{max}}$			15			mV <sub>pp</sub>
		Total incl. spikes	BW = 20 MHz			40			
$V_{od}$	Dynamic load regulation	Voltage deviation	$V_{i\text{nom}}$			1.2			V
$t_d$ <sup>5</sup>		Recovery time	$I_{o\text{max}} \leftrightarrow \frac{1}{2} I_{o\text{max}}$			0.2			0.15
$V_{otr}$	Output voltage trim range (via R-input)	$1.1 V_{i\text{min}} - V_{i\text{max}}$ $(0.1 - 1) I_{o\text{max}}$	8.1		16.5	13		26.4	V
$\alpha_{vo}$	Temperature coefficient of $V_o$	$\frac{I_{o\text{nom}}}{T_{C\text{min}} - T_{C\text{max}}}$	±0.02			±0.02			%/K

<sup>1</sup> If the output voltages are increased above  $V_{o\text{nom}}$  through R-input control or remote sensing, the output power should be reduced accordingly, so that  $P_{o\text{max}}$  and  $T_{C\text{max}}$  are not exceeded.

<sup>2</sup> Breakdown voltage of the incorporated suppressor diode at 10 mA (3.3 V, 5.1 V) or 1 mA ( $\geq 12$  V). Value for 3.3 V for version  $\geq 112$ . Exceeding this value might damage the suppressor diode.

<sup>3</sup> See *Output Power at Reduced Temperature*

<sup>4</sup> Measured according to IEC/EN 61204 with a probe described in annex A

<sup>5</sup> Recovery time until  $V_o$  returns to  $\pm 1\%$  of  $V_o$ ; see *Dynamic Load Regulation*

<sup>6</sup> Output voltage limitation by an additional electronic shutdown



Table 5c: Output data for double-output powertrains. General conditions as in table 5a.

Output train		Double-output power-train	5.1 V						12 V						Unit
			Main output			Tracking output			Main output			Tracking output			
Characteristics		Conditions	min	typ	max	min	typ	max	min	typ	max	min	typ	max	
$V_o$	Output voltage <sup>1</sup>	$V_{i\text{nom}} \cdot I_{o\text{nom}}$	5.05	5.1	5.15	5.0	5.1	5.2	11.88	12	12.12	11.76	12	12.24	V
$V_{ow}$	Worst case output voltage	$V_{i\text{min}} - V_{i\text{max}}$ $T_{C\text{min}} - T_{C\text{max}}$ $(0.02 - 1) I_{o\text{nom}}$	4.95		5.25	See Output Voltage Regulation			11.82		12.18	See Output Voltage Regulation			
$V_{oP}$	Overvoltage protection <sup>2</sup>		none			6.45		6.8	none			14.3	15	15.8	
$V_{oL}$	Overvoltage limitation <sup>6</sup>		none					6.5	none			14.4			
$I_{o\text{nom}}$	Nominal output current		5.0			5.0			2.5			2.5			A
$I_{o\text{max}}$	Max. output current	$V_{i\text{min}} - V_{i\text{max}}$	8.0			8.0			4			4			
$I_{oL}$	Output current limit <sup>3</sup>	$T_{C\text{min}} - T_{C\text{max}}$	17			20			8.4			10			
$V_o$	Output noise <sup>4</sup>	Switch. frequency	$V_{i\text{nom}} \cdot I_{o\text{max}}$			5			15			15			mV <sub>pp</sub>
		Total incl. spikes	BW = 20 MHz			20			30			30			
$V_{od}$	Dynamic load regulation	Voltage deviation	$V_{i\text{nom}}$			0.8			1.2			1.2			V
$t_d$ <sup>5</sup>		Recovery time	$I_{o\text{max}} \leftrightarrow \frac{1}{2} I_{o\text{max}}$			0.3			0.15			0.15			ms
$V_{otr}$	Output voltage trim range (via R-input)	$1.1 V_{i\text{min}} - V_{i\text{max}}$ $(0.1 - 1) I_{o\text{max}}$	2.75		5.61	See Output Voltage Regulation			6.5		13.2	See Output Voltage Regulation			V
$\alpha_{vo}$	Temperature coefficient of $V_o$	$I_{o\text{nom}}$ , $T_{C\text{min}} - T_{C\text{max}}$	±0.02						±0.02						%/K

Table 5d: Output data for double-output powertrains. General conditions as in table 5a.

Output		Double-output powertrain	15 V						24 V						Unit
			Main output			Tracking output			Main output			Tracking output			
Characteristics		Conditions	min	typ	max	min	typ	max	min	typ	max	min	typ	max	
$V_o$	Output voltage <sup>1</sup>	$V_{i\text{nom}} \cdot I_{o\text{nom}}$	14.85	15	15.15	14.7	15	15.3	23.88	24	24.12	23.76	24	24.24	V
$V_{ow}$	Worst case output voltage	$V_{i\text{min}} - V_{i\text{max}}$ $T_{C\text{min}} - T_{C\text{max}}$ $(0.02 - 1) I_{o\text{nom}}$	14.78		15.23	See Output Voltage Regulation			23.64		24.36	See Output Voltage Regulation			
$V_{oP}$	Overvoltage protection <sup>2</sup>		none			17.1		18.9	none			28.5	30	31.5	
$V_{oL}$	Overvoltage limitation <sup>6</sup>		none						none			28.8			
$I_{o\text{nom}}$	Nominal output current		2			2			1.25			1.25			A
$I_{o\text{max}}$	Max. output current <sup>3</sup>	$V_{i\text{min}} - V_{i\text{max}}$	3.2			3.2			2			2			
$I_{oL}$	Output current limit	$T_{C\text{min}} - T_{C\text{max}}$	6.8			8.2			4.2			5.0			
$V_o$	Output noise <sup>4</sup>	Switch. frequency	$V_{i\text{nom}} \cdot I_{o\text{max}}$			15			15			15			mV <sub>pp</sub>
		Total incl. spikes	BW = 20 MHz			40			50			50			
$V_{od}$	Dynamic load regulation	Voltage deviation	$V_{i\text{nom}}$			1.2			1.5			1.5			V
$t_d$ <sup>5</sup>		Recovery time	$I_{o\text{max}} \leftrightarrow \frac{1}{2} I_{o\text{max}}$			0.2			0.15			0.15			ms
$V_{otr}$	Output voltage trim range (via R-input)	$1.1 V_{i\text{min}} - V_{i\text{max}}$ $(0.1 - 1) I_{o\text{max}}$	8.1		16.5	See Output Voltage Regulation			13		26.4	See Output Voltage Regulation			V
$\alpha_{vo}$	Temperature coefficient of $V_o$	$I_{o\text{nom}}$ , $T_{C\text{min}} - T_{C\text{max}}$	±0.02						±0.02						%/K

<sup>1</sup> If the output voltages are increased above  $V_{o\text{nom}}$  through R-input control or remote sensing, the output power should be reduced accordingly, so that  $P_{o\text{max}}$  and  $T_{C\text{max}}$  are not exceeded.  
<sup>2</sup> Breakdown voltage of the incorporated suppressor diode at 1 mA. Exceeding this voltage might damage the suppressor diode.  
<sup>3</sup> See Output Power at Reduced Temperature  
<sup>4</sup> Measured according to IEC/EN 61204 with a probe described in annex A  
<sup>5</sup> Recovery time until  $V_o$  returns to ±1% of  $V_o$ ; see Dynamic Load Regulation  
<sup>6</sup> Output voltage limitation by an additional control loop



### Parallel and Series Connection

The first outputs of power trains with equal nominal output voltage can be connected in parallel. Where available, we recommend ordering option T.

Any output can be connected in series with any other output. If the main and the tracking output of the same power train are connected in series, consider that the effect of the R-input is doubled.

**Notes:**

- If a tracking output is not used, connect it in parallel to the respective regulated main output.
- Connection of several outputs in parallel should include measures to approximate all output currents. 3.3 and 5 V outputs with option T have current-share pins (T), which must be interconnected. For other outputs, the load lines should exhibit similar resistance. Parallel connection of regulated outputs without such precautions is not recommended.
- The maximum output current of series-connected outputs is limited by the output with the lowest current limit.
- Rated output voltages above 48 V (ES1 = energy source class 1) require additional safety measures in order to comply with international safety standards.

Parallel operation of two double-output converters with series-connected outputs is shown in fig. 10. The link between the T pins ensures proper current sharing, even though only the first outputs are influenced by T. Sense lines are connected directly at the connector, and load lines have equal length and section.

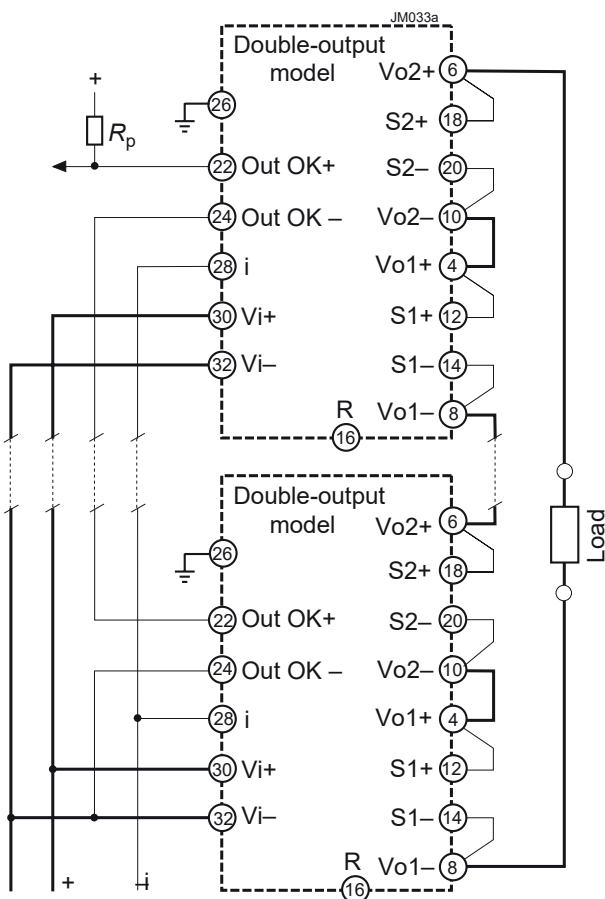

Fig. 9  
Series connection of double-output models.  
Sense lines connected at the connector.

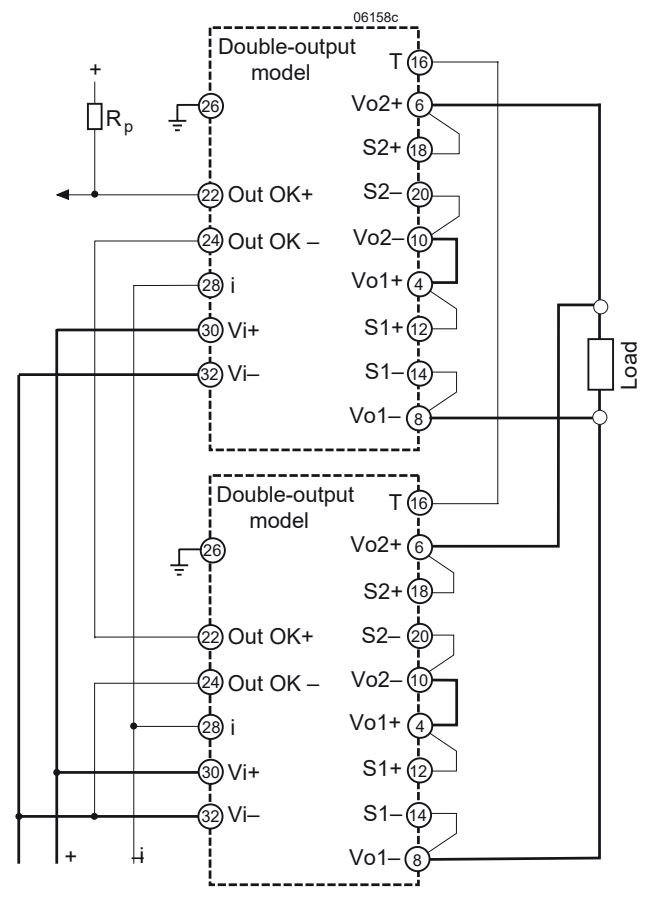

Fig. 10  
Parallel operation of 2 double-output converters with series-connected outputs.

### Redundant Systems

An example of a redundant system using converters with 2 regulated outputs (xP2020) is shown in fig. 11. Load 1 is powered with 5.1 V and load 2 with 12 V.

The converters are separated with ORing diodes. If one converter fails, the remaining one still delivers the power to the loads. If more power is needed, the system may be extended to more parallel converters (n+1 redundancy).

Current sharing of the 5.1 V outputs is ensured by the interconnected T pins, whereas the sense lines are connected after the ORing diodes to maintain the correct output voltage.

For the 12 V outputs, no current-share feature (option T) is available. As a result, 2 little diodes  $D_s$  (loaded by little resistors  $R_s$ ) simulate the voltage drop of the ORing diodes. Reasonable current sharing is provided by load lines of equal length and section.

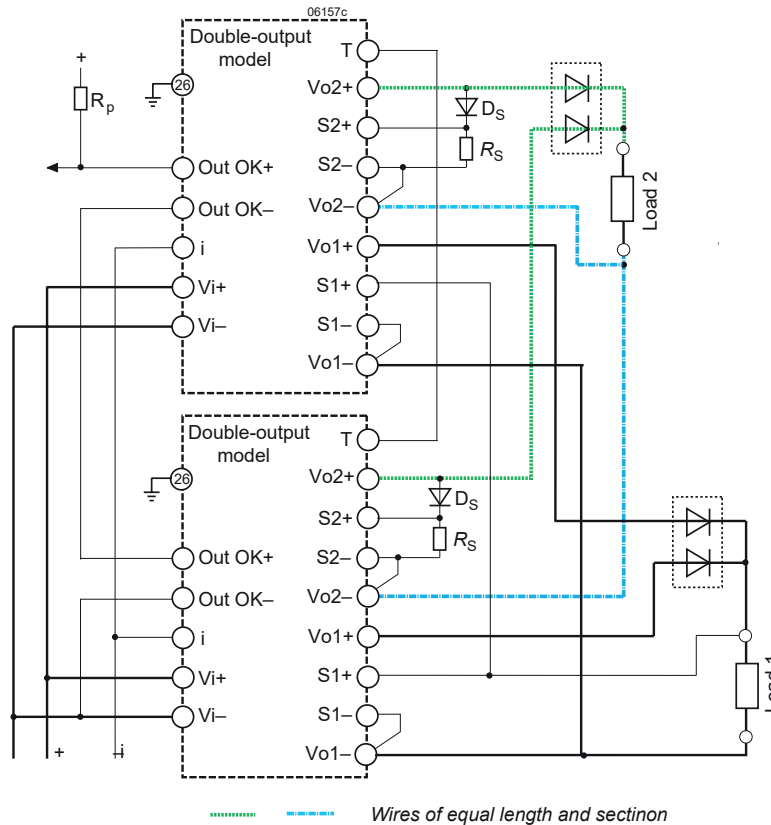

Fig. 11  
Redundant configuration

### Hot Swap

Important: For applications using the hot swap capabilities, dynamic output voltage changes during plug-in and plug-out operations may occur.

### Hold-up time

The converters provide virtually no interruption time. If an interruption time is required, use external output capacitors or input capacitors of adequate size and decoupling diodes.

Formula for additional external input capacitor:

$$C_{i\text{ext}} = \frac{2 \cdot P_o \cdot t_h \cdot 100}{(V_{ti}^2 - V_{i\text{min}}^2) \cdot \eta}$$

whereas:

$C_{i\text{ext}}$	[mF]	= external input capacitance
$P_o$	[W]	= output power
$h$	[%]	= efficiency
$t_h$	[ms]	= hold-up time [ms]
$V_{i\text{min}}$	[V]	= minimum input voltage
$V_{ti}$	[V]	= threshold level

### Output Voltage Regulation

Line and load regulation of the regulated outputs is so good that input voltage and output current have virtually no influence to the output voltage.

However, if the tracking output is not loaded, the second control loop may slightly reduce the voltage of the main output. Thus, unused tracking outputs should be connected in parallel to the respective main output.

The dynamic load regulation is shown in fig. 12.

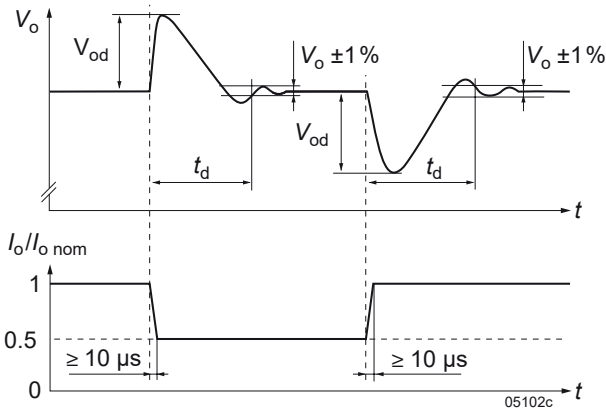

Fig. 12  
Typical dynamic load regulation of output voltage

### Tracking Outputs

The main outputs 1 and 2 are regulated to  $V_{o,nom}$  independent of the output current. If the loads on outputs 3 and 4 are too low (<10% of  $I_{o,nom}$ ), their output voltage tends to rise.  $V_{o3}$  and  $V_{o4}$  depend upon the load distribution: If all outputs are loaded with at least 10% of  $I_{o,nom}$ ,  $V_{o3}$  and  $V_{o4}$  remain within  $\pm 5\%$  of  $V_{o,nom}$ . The diagrams fig. 13 to 16 show the regulation of the tracking output under different load conditions up to the current limit. If  $I_{o1} = I_{o4}$  and  $I_{o2} = I_{o3}$  or if the tracking outputs are connected in series with their respective regulated outputs, then  $V_{o3}$  and  $V_{o4}$  remain within  $\pm 1\%$  of  $V_{o,nom}$  provided that the load is at least  $I_{o,min}$ . A 2<sup>nd</sup> control loop protects the tracking outputs against overvoltage by reducing the voltage of the respective regulated main output.

Because the P Series converters exhibit main transformers and main chokes in planar technology, the tracking outputs follow the main outputs very closely.

**Note:** If the tracking output ( $V_{o3}$  or  $V_{o4}$ ) is not loaded, it should be connected in parallel to the respective main output ( $V_{o3}$  parallel to  $V_{o2}$ ,  $V_{o4}$  parallel to  $V_{o1}$ ).

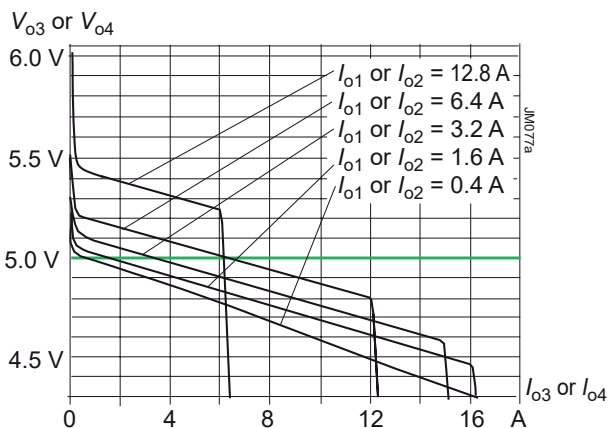

Fig. 13  
5 V tracking output  $V_{o4}$  versus  $I_{o4}$  (powertrain 1) or  $V_{o3}$  versus  $I_{o3}$  (powertrain 2).  $V_i = V_{i,nom}$

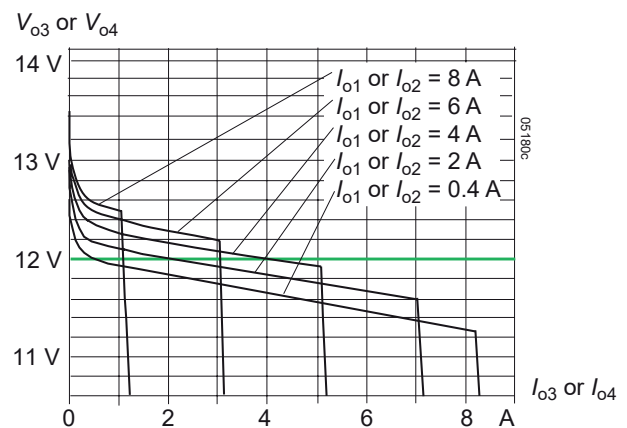

Fig. 14  
12 V tracking output  $V_{o4}$  versus  $I_{o4}$  (powertrain 1) or  $V_{o3}$  versus  $I_{o3}$  (powertrain 2).  $V_i = V_{i,nom}$

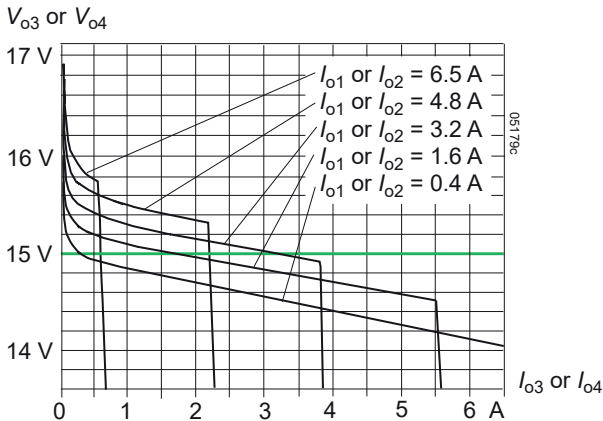

Fig. 15  
15 V tracking output  $V_o = f(I_o)$ ,  $V_i = V_{i,nom}$

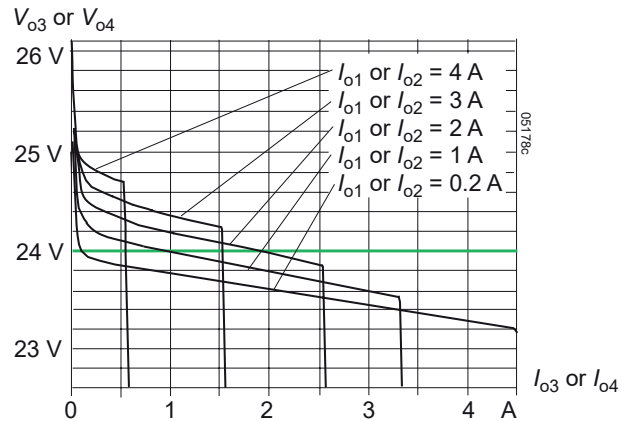

Fig. 16  
24 V tracking output  $V_o = f(I_o)$ ,  $V_i = V_{i,nom}$

### Output Current Limitation

All outputs are continuously protected against open-circuit (no load) and short-circuit by an electronic current limitation.

Single- and double-output powertrains have a rectangular current limitation characteristic. In double output power-trains only the total current is limited allowing free choice of load distribution between the two outputs of each power train up to a total  $I_{o1} + I_{o4} = I_{o,max}$  or  $I_{o2} + I_{o3} = I_{o,max}$ .

### Thermal Considerations and Protection

If a converter is mounted upright in free air, allowing unrestricted convection cooling, and is operated at its nominal input voltage and output power at  $T_{A,max}$  (see table *Temperature specifications*), the temperature measured at the measurement point on the case  $T_C$  (see *Mechanical Data*) will approach  $T_{C,max}$  after an initial warm-up phase. However the relationship between  $T_A$  and  $T_C$  depends heavily on the operating conditions and system integration. The thermal conditions are influenced significantly by the input voltage, the output current, airflow, and the temperature of the adjacent elements and surfaces.  $T_{A,max}$  is therefore contrary to  $T_{C,max}$  only an indicative value.

A temperature sensor fitted on the main PCB disables the output, when the case temperature exceeds  $T_{C,max}$ . The converter automatically resumes, when the temperature drops below this limit. An additional temperature sensor on each power train reduces the output current limit of that power train, when the temperature exceeds a safe level.

### Output Power at Reduced Temperature

Operating the converters with an output current between  $I_{o,nom}$  and  $I_{o,max}$  requires a reduction of the ambient temperature or forced air cooling, in order to keep  $T_C$  below  $95^\circ\text{C}$ ; see fig 17. When  $T_{C,max}$  is exceeded, the thermal protection is activated and disables the outputs.

**Note:** Forced cooling or an additional heat sink can improve the reliability or allow  $T_A$  to go beyond  $T_{A,max}$ , provided that  $T_{C,max}$  is not exceeded. In rack systems without proper thermal management the converters should not be packed too closely together! In such cases the use of a 5 or 6 TE front panel is recommended.

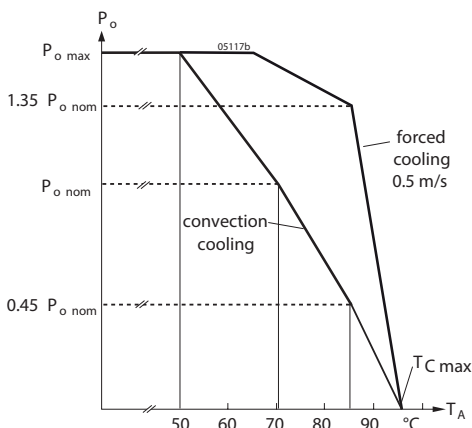

Fig. 17  
Output power derating versus  $T_A$ .



Asia-Pacific +86 755 298 85888 EMEA +353 61 531 820 North America +1 866 513 2839

powersupport@belf.com  
belfuse.com



## Auxiliary Functions

### Primary Inhibit (Remote On / Off)

The inhibit input enables (logic low, pull down) or disables (logic high, pull up or open-circuit) the output, if a logic signal (TTL, CMOS) is applied. In systems consisting of several converters, this feature may be used to control the activation sequence by logic signals or to enable the power source to start up, before full load is applied.

The output response after enabling or disabling the output with the inhibit input is shown in the figure below. See also *Input Data*.

**Note:** If this function is not used, pin 28 must be connected with pin 32, otherwise the internal logic will disable the output.

Table 6: Inhibit characteristics

Characteristics		Conditions	min	typ	max	Unit
$V_{inh}$	Inhibit voltage	$V_o = on$	$V_{i min} - V_{i max}$	-50	0.8	V
		$V_o = off$	$T_{C min} - T_{C max}$	2.4	50	
$I_{inh}$	Inhibit current	$V_{inh} = -50 V$		-1000		$\mu A$
		$V_{inh} = 0 V$		-40		
		$V_{inh} = 50 V$		900		

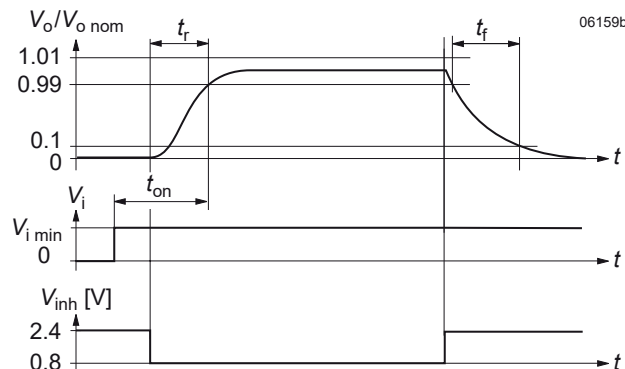

Fig. 18  
Output response as a function of  $V_i$  (on/off switching) or inhibit control

### Output Voltage Adjust of $V_{o1}$ and $V_{o4}$

**Note:** With open R-input,  $V_o = V_{o nom}$ .

The converters allow for adjustment of the voltage of powertrain 1. Powertrain 2 can not be adjusted (except for single-output models). The programming is performed either by an external control voltage  $V_{ext}$  or an external resistor  $R_1$  or  $R_2$ , connected to the R-input. Trimming is limited to the values given in the table *Electrical Output Data*.

With double-output powertrains, both outputs are influenced by the R-input setting simultaneously.

**Caution:** To prevent damage,  $V_{ext}$  should not exceed 20 V, nor be negative.

**Note:** If output voltages are set higher than  $V_{o nom}$ , the output currents should be reduced accordingly, so that the maximum specified output power is not exceeded.

a) Adjustment by means of an external voltage:

$$V_{ext} \approx \frac{2.72 V_{o1}}{V_{o nom}} - 0.28 V$$

b) Adjustment by means of an external resistor:

The adjust resistor  $R_1$  is connected between pin 16 and S- (14) to set  $V_o < V_{o nom}$ , (see table 7a), or the adjust resistor  $R_2$  is connected between pin 16 and S+ (12) to set  $V_o > V_{o nom}$  (see table 7b).

**Note:** R inputs of n converters with paralleled outputs may be connected together, but if only one external resistor is used, its value should be  $R_1/n$  or  $R_2/n$ .

# P Series

## 90 - 192 W DC-DC Converters

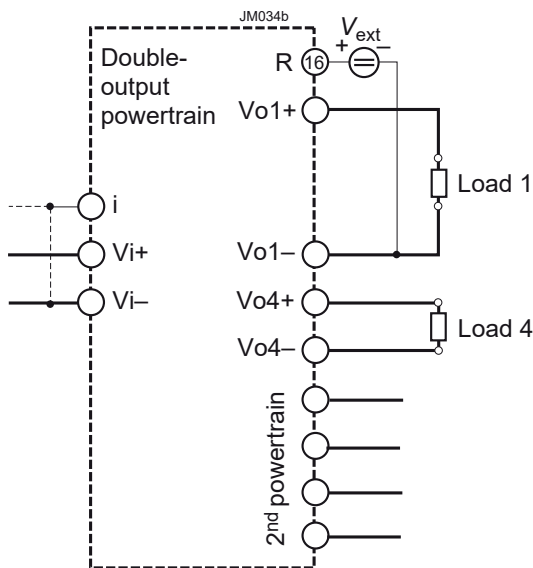

Fig. 19 Output adjust of  $V_{o1}$  and  $V_{o4}$  with an external voltage  $V_{ext}$ . The other outputs are not influenced.

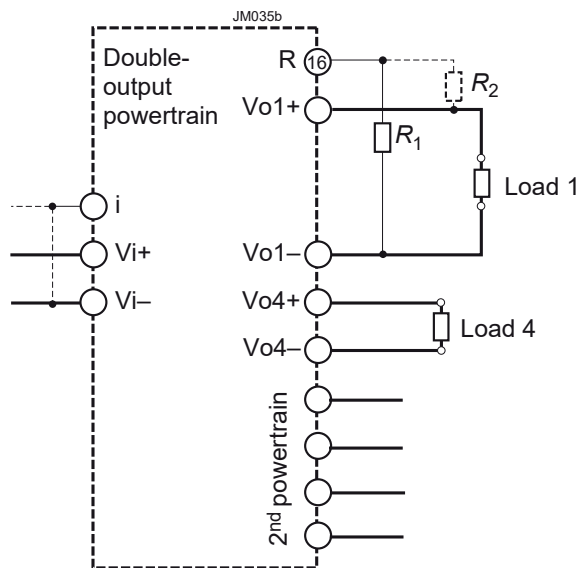

Fig. 20 Output adjust of  $V_{o1}$  and  $V_{o4}$  using  $R_1$  or  $R_2$ . The other outputs are not influenced.

Table 7a:  $R_1$  for  $V_o < V_{o,nom}$ ; approximate values ( $V_{i,nom}$ ,  $I_{o,nom}$ , series E 96 resistors);  $R_2$  not fitted

$V_{o,nom} = 3.3\text{ V}$		$V_{o,nom} = 5.1\text{ V}$		$V_{o,nom} = 12\text{ V}$		$V_{o,nom} = 15\text{ V}$		$V_{o,nom} = 24\text{ V}$				
$V_o\text{ (V)}$	$R_1\text{ [k}\Omega\text{]}$	$V_o\text{ (V)}$	$R_1\text{ [k}\Omega\text{]}$	$V_o\text{ (V)}^1$		$V_o\text{ (V)}^1$		$V_o\text{ (V)}^1$				
2.0	5.62	4.0	14.0	6.5	13	4.22	8.0	16	4.12	14	28	5.23
2.1	6.49	4.1	15.8	7.0	14	5.11	8.5	17	4.75	15	30	6.19
2.2	7.50	4.2	18.2	7.5	15	6.19	9.0	18	5.49	16	32	7.5
2.3	8.66	4.3	21.0	8.0	16	7.5	9.5	19	6.34	17	34	9.31
2.4	10.2	4.4	24.3	8.5	17	9.1	10.0	20	7.5	18	36	11.5
2.5	12.1	4.5	29.4	9.0	18	11.5	10.5	21	8.87	19	38	14.7
2.6	14.3	4.6	36.5	9.5	19	14.7	11.0	22	10.5	20	40	19.6
2.7	17.4	4.7	47.5	10.0	20	19.6	11.5	23	12.7	20.5	41	22.9
2.8	22.1	4.8	63.4	10.5	21	27.4	12.0	24	15.4	21	42	27.4
2.9	28.7	4.9	97.6	11.0	22	43.2	12.5	25	29.6	21.5	43	34.0
3.0	39.2	5.0	200	11.5	23	88.7	13.0	26	25.5	22	44	43.2
3.1	61.9						13.5	27	34.8	22.5	45	59.0
3.2	12.7						14.0	28	54.9	23	46	88.7
							14.5	29	110	23.5	47	182

Table 7b:  $R_2$  for  $V_o > V_{o,nom}$ ; approximate values ( $V_{i,nom}$ ,  $I_{o,nom}$ , series E 96 resistors);  $R_1$  not fitted

$V_{o,nom} = 3.3\text{ V}$		$V_{o,nom} = 5.1\text{ V}$		$V_{o,nom} = 12\text{ V}$		$V_{o,nom} = 15\text{ V}$		$V_{o,nom} = 24\text{ V}$				
$V_o\text{ (V)}$	$R_1\text{ [k}\Omega\text{]}$	$V_o\text{ (V)}$	$R_1\text{ [k}\Omega\text{]}$	$V_o\text{ (V)}^1$		$V_o\text{ (V)}^1$		$V_o\text{ (V)}^1$				
3.4	47.5	5.2	226	12.2	24.4	1100	15.3	30.6	1130	24.5	49.0	1820
3.5	24.3	5.3	115	12.4	24.8	499	15.5	31.0	665	25.0	50.0	909
3.6	16.3	5.4	78.7	12.6	25.2	332	15.7	31.4	475	25.5	51.0	604
		5.5	59	12.8	25.6	255	16.0	32.0	332	26.0	52.0	464
		5.6	48.7	13.0	26.0	205	16.2	32.4	280	26.4	52.8	392
				13.2	26.4	174	16.5	33.0	232			

<sup>1</sup> First column: single-output powertrains or double-output powertrains with separated/paralleled outputs, second column: outputs in series connection.



Asia-Pacific +86 755 298 85888 EMEA +353 61 531 820 North America +1 866 513 2839

powersupport@belf.com  
belfuse.com



### Sense Lines

**Important:** Sense lines should always be connected. Incorrectly connected sense lines may damage the converter. If sense pins are left open-circuit, the output voltages are not accurate.

This feature enables compensation of voltage drop across the connector contacts and the load lines including ORing diodes in true redundant systems.

Applying generously dimensioned cross-section load leads avoids troublesome voltage drop. To minimize noise pick-up, wire sense lines parallel or twisted to the respective output line. To be sure, connect the sense lines directly at the female connector.

The voltage difference between any sense line and its respective power output pin (as measured on the connector) should not exceed the following values at nominal output voltage.

Table 8: Voltage compensation allowed using sense lines

Output type	Total drop	Negative line drop
3.3, 5.1 V output	< 0.5 V	< 0.25 V
12, 15, 24 V output	< 1.0 V	< 0.50 V

### LED Indicators

The P Series converters exhibit a green LED "In OK", signalling that the input voltage is within the specified range provided that the unit is not disabled by inhibit signal.

A green LED "Out-OK" indicates for each powertrain that the respective power train is working correctly, i.e. that its output control loop is locked. This proves with high probability that the regulated output exhibit the correct voltage; see also *Option D*.

**Note:** Single-output models exhibit only 1 LED "Out-OK".

### 2<sup>nd</sup> Control Loop

The 2<sup>nd</sup> output voltage of double-output power trains is watched by an independent monitoring circuit. In the case of an overvoltage, the primary control logic of the power train is influenced to reduce the duty cycle, resulting in a lower voltage on both outputs. Such an overvoltage may occur, when the 1<sup>st</sup> output is fully charged and the 2<sup>nd</sup> output is nearly unloaded – particularly with dynamic load changes.





## Electromagnetic Compatibility (EMC)

A metal oxide VDR together with an input fuse and a symmetrical input filter form an effective protection against high input transient voltages, which typically occur in most installations, but especially in battery-driven mobile applications. The P Series has been successfully tested to the following specifications:

### Electromagnetic Immunity

Table 9: Electromagnetic immunity (type tests)

Phenomenon	Standard	Level	Coupling mode <sup>1</sup>	Value applied	Waveform	Source impeded.	Test procedure	In oper.	Perf. crit. <sup>2</sup>
Supply related surge	EN 50155:2007 clause 12.2.6	-	+i/-i	$1.4 \cdot V_{batt}$	0.1/1.0/0.1 s	0.2 $\Omega$	1 positive	yes	A
Electrostatic discharge (to case)	IEC/EN 61000-4-2	4 <sup>4</sup>	contact discharge	8000 V <sub>p</sub>	1/50 ns	330 $\Omega$ 150 pF	10 pos. & 10 neg. discharges	yes	B
			air discharge	15000 V <sub>p</sub>					
Electromagnetic field	IEC/EN 61000-4-3	x <sup>5</sup>	antenna	20 V/m	AM 80% / 1 kHz	N/A	80 – 800 MHz	yes	A
		6	antenna	20 V/m	AM 80% / 1 kHz	N/A	800 – 1000 MHz	yes	A
				10 V/m			1400 – 2000 MHz		
				5 V/m			2000 – 2700 MHz		
3 V/m	5100 – 6000 MHz								
Electrical fast transients / burst	IEC/EN 61000-4-4	3 <sup>7</sup>	direct coupling, +i/c, -i/c, +i/-i,	$\pm 2000 V_p$ <sup>7</sup>	bursts of 5/50 ns; 5 kHz over 15 ms; burst period: 300 ms	50 $\Omega$	60 s positive 60 s negative transients per coupling mode	yes	A
		4		$\pm 4000 V_p$				yes	B
		3	capacit. coupl., o/c	$\pm 2000 V_p$				yes	A
Surges	IEC/EN 61000-4-5	3 <sup>3</sup>	+i/c, -i/c,	$\pm 2000 V_p$ <sup>3</sup>	1.2 / 50 $\mu$ s	12 $\Omega$ /9 $\mu$ F 2 $\Omega$ /18 $\mu$ F	5 pos. & 5 neg. surges per coupling mode	yes	A
			+i/-i	$\pm 1000 V_p$ <sup>3</sup>					
Conducted disturbances	IEC/EN 61000-4-6	3 <sup>8</sup>	i, o, signal wires	10 VAC (140 dB $\mu$ V)	AM 80% / 1 kHz	150 $\Omega$	0.15 – 80 MHz	yes	A
Power frequency magnetic field	IEC/EN 61000-4-8	9	-	300 A/m			60 s in all 3 axes	yes	A

<sup>1</sup> i = input, o = output, c = case.

<sup>2</sup> A = normal operation, no deviation from specs; B = temporary loss of function or deviation from specs possible.

<sup>3</sup> Measured with an external input cap specified in table 4. Exceeds EN 50121-3-2:2016 table 3.3 and EN 50121-4:2016 table 4.3.

<sup>4</sup> Exceeds EN 50121-3-2:2016 table 5.3 and EN 50121-4:2016 table 2.4.

<sup>5</sup> Corresponds to EN 50121-3-2:2016 table 5.1 and exceeds EN 50121-4:2016 table 2.1.

<sup>6</sup> Corresponds to EN 50121-3-2:2016 table 5.2 and EN 50121-4:2016 table 2.2.

<sup>7</sup> Corresponds to EN 50121-3-2:2016 table 3.2 and EN 50121-4:2016 table 4.2.

<sup>8</sup> Corresponds to EN 50121-3-2:2016 table 3.1 and EN 50121-4:2016 table 4.1 (radio frequency common mode).

<sup>9</sup> Corresponds to EN 50121-4:2016 table 2.3.

### Electromagnetic Emissions

All conducted emissions (fig. 21) have been tested according to EN 55011, group 1, class A. These limits are much stronger than requested in EN 50121-3-2:2016, table 2.1, and correspond to EN 50121-4:2016, table 1.1. The limits in fig. 21 apply to quasipeak values, which are always lower than peak values.

In addition, the values for average must keep a limit 10 dB $\mu$ V below the limits in fig. 21 (not shown).

Radiated emissions have been tested according to EN 55011 group 1, class A. These limits are similar to the requirements of EN 50121-3-2:2016 and EN 50121-4:2016, calling up EN 61000-6-4+A1:2011, table 1. The test was executed with horizontal and vertical polarization. The worse result is shown in fig. 22.

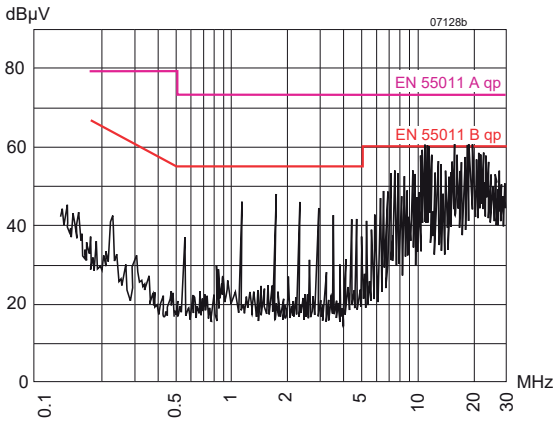

Fig. 21a  
BP 2320-9RD  
Typ. conducted disturbance voltage at the input  
( $V_{i\text{nom}}$ ,  $I_{i\text{nom}}$ , resistive load, quasi peak).

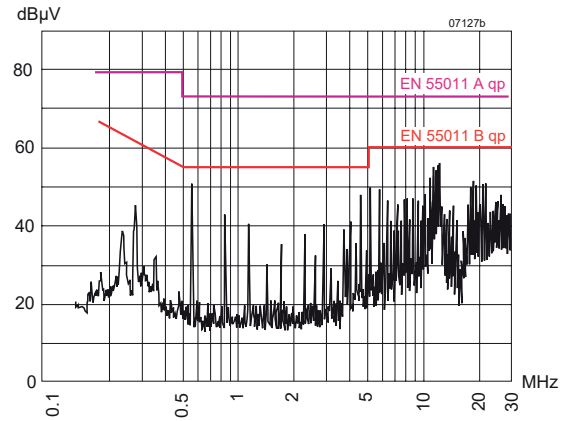

Fig. 21b  
CP 1001-7RB1  
Typ. conducted disturbance voltage at the input  
( $V_{i\text{nom}}$ ,  $I_{i\text{nom}}$ , resistive load, quasi peak).

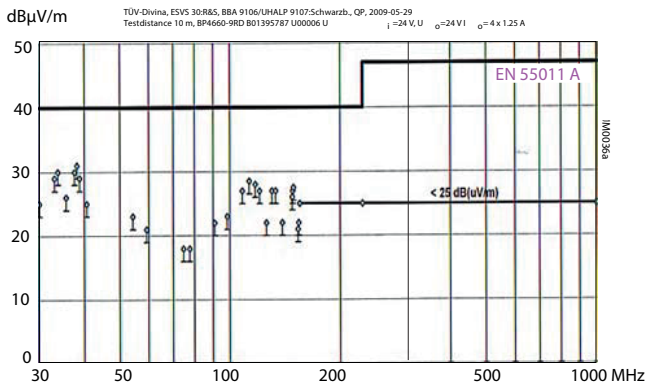

Fig. 22a  
Radiated disturbances (quasi peak) in 10 m distance:  
BP4660-9RD,  $V_{i\text{nom}}$ ,  $V_o = 24\text{ V}$ ,  $I_o = 4 \times 1.25\text{ A}$

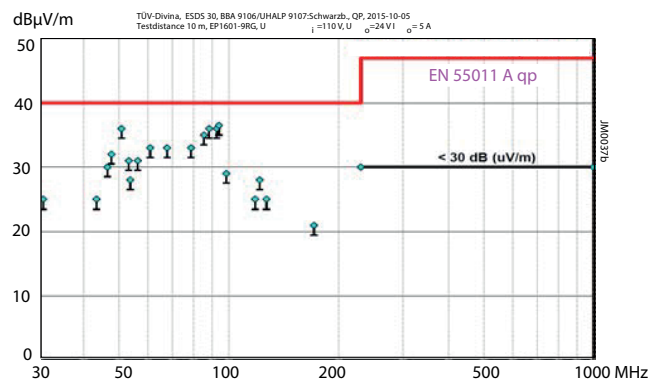

Fig. 22b  
Radiated disturbances (quasi peak) in 10 m distance:  
EP1601-9RG,  $V_{i\text{nom}} = 110\text{ V}$ ,  $V_o = 24\text{ V}$ ,  $I_o = 5\text{ A}$

## Immunity to Environmental Conditions

Table 10: Mechanical and climatic stress

Test method		Standard	Test Conditions		Status
Cab	Damp heat steady state	IEC/EN 60068-2-78 MIL-STD-810D section 507.2	Temperature:	40 ±2 °C	Converter not operating
			Relative humidity:	93 ±2/-3 %	
			Duration:	56 days	
Db	Damp heat test, cyclic	EN50155:2017, clause 13.4.7 IEC/EN 60068-2-30	Temperature:	55 °C and 25 °C	Converter not operating
			Cycles (respiration effect)	2	
			Duration:	2x 24 h	
Bd	Dry heat test steady state	EN50155:2017, clause 13.4.5 IEC/EN 60068-2-2	Temperature:	70 °C	Converter operating
			Duration:	6 h	
Ad	Cooling test steady state	EN50155:2017, clause 13.4.4 IEC/EN 60068-2-1	Temperature, duration:	-40 °C, 2 h	Converter not operating
			Performance test:	+25 °C	
Ka	Salt mist test sodium chloride	EN50155:2017, clause 13.4.10 EN 60068-2-11, class ST2	Temperature:	35 ±2 °C	Converter not operating
			Duration:	16 h	
Fc	Vibration (sinusoidal)	IEC/EN 60068-2-6 MIL-STD-810D section 514.3	Acceleration amplitude:	0.35 mm (10 – 60 Hz) 5 g <sub>n</sub> = 49 m/s <sup>2</sup> (60 - 2000 Hz)	Converter operating
			Frequency (1 Oct/min):	10 – 2000 Hz	
			Test duration:	7.5 h (2.5 h in each axis)	
Fh	Random vibration broad band (digital control) & guidance	IEC/EN 60068-2-64	Acceleration spectral density:	0.05 g <sub>n</sub> <sup>2</sup> /Hz	Converter operating
			Frequency band:	8 – 500 Hz	
			Acceleration magnitude:	4.9 g <sub>n,rms</sub>	
			Test duration:	1.5 h (0.5 h in each axis)	
Ea	Shock (half-sinusoidal)	IEC/EN 60068-2-27 MIL-STD-810D section 516.3	Acceleration amplitude:	50 g <sub>n</sub> = 490 m/s <sup>2</sup>	Converter operating
			Bump duration:	11 ms	
			Number of bumps:	18 (3 in each direction)	
	Shock	EN50155:2017, clause 13.4.11 EN 61373 sect. 10 class B, body mounted <sup>1</sup>	Acceleration amplitude:	5.1 g <sub>n</sub>	Converter operating
			Bump duration:	30 ms	
			Number of bumps:	18 (3 in each direction)	
	Simulated long life testing at increased random vibration levels	EN50155:2017, clause 13.4.11 EN 61373 sect. 8 and 9 class B, body mounted <sup>1</sup>	Acceleration spectral density:	0.02 g <sub>n</sub> <sup>2</sup> /Hz	Converter operating
			Frequency band:	5 – 150 Hz	
			Acceleration magnitude:	0.8 g <sub>n,rms</sub>	
			Test duration:	15 h (5 h in each axis)	

<sup>1</sup> Body mounted = chassis of a railway coach

## Temperatures

Table 11: Temperature specifications, valid for an air pressure of 800 – 1200 hPa (800 – 1200 mbar)

Model		-7 (option)			-9 (standard)			Unit		
Characteristics		Conditions		min	typ	max	min		typ	max
T <sub>A</sub>	Ambient temperature	Converter operating <sup>1</sup>		- 25		71	- 40		71	° C
T <sub>C</sub>	Case temperature <sup>2</sup>			- 25		95 <sup>1</sup>	- 40		95 <sup>1</sup>	
T <sub>S</sub>	Storage temperature	Not operational		- 40		85	- 55		85	
R <sub>th CA</sub>	Thermal resistance case to ambient in still air				1.6 <sup>3</sup>			1.6 <sup>3</sup>		K/W

<sup>1</sup> Operation with P<sub>o,max</sub> requires reduction to T<sub>A,max</sub> = 50 °C, T<sub>C,max</sub> = 85° C respectively; see *Thermal Considerations*.

<sup>2</sup> Overtemperature shutdown at T<sub>C</sub> >95 °C (temperature sensor)

<sup>3</sup> See table 17 for long case and heatsink options B0, B1, B3.

Reliability

Table 12: MTBF and device hours

Ratings at specified case temperature	Model	Ground benign		Ground fixed		Ground mobile	Demonstrated hours between failures <sup>1</sup>
		40° C	40° C	70° C	50° C		
MTBF acc. toMIL-HDBK-217F, notice 2	CP	340 000 h	88 000 h	42 000 h	40 000 h	757 000 h	

<sup>1</sup> Statistical values, based upon an average of 4300 working hours per year and in general field use over 5 years; upgrades and customer-induced errors are excluded.

Mechanical Data

The converters are designed for insertion into a 19" rack according to IEC 60297-3. Dimensions in mm.

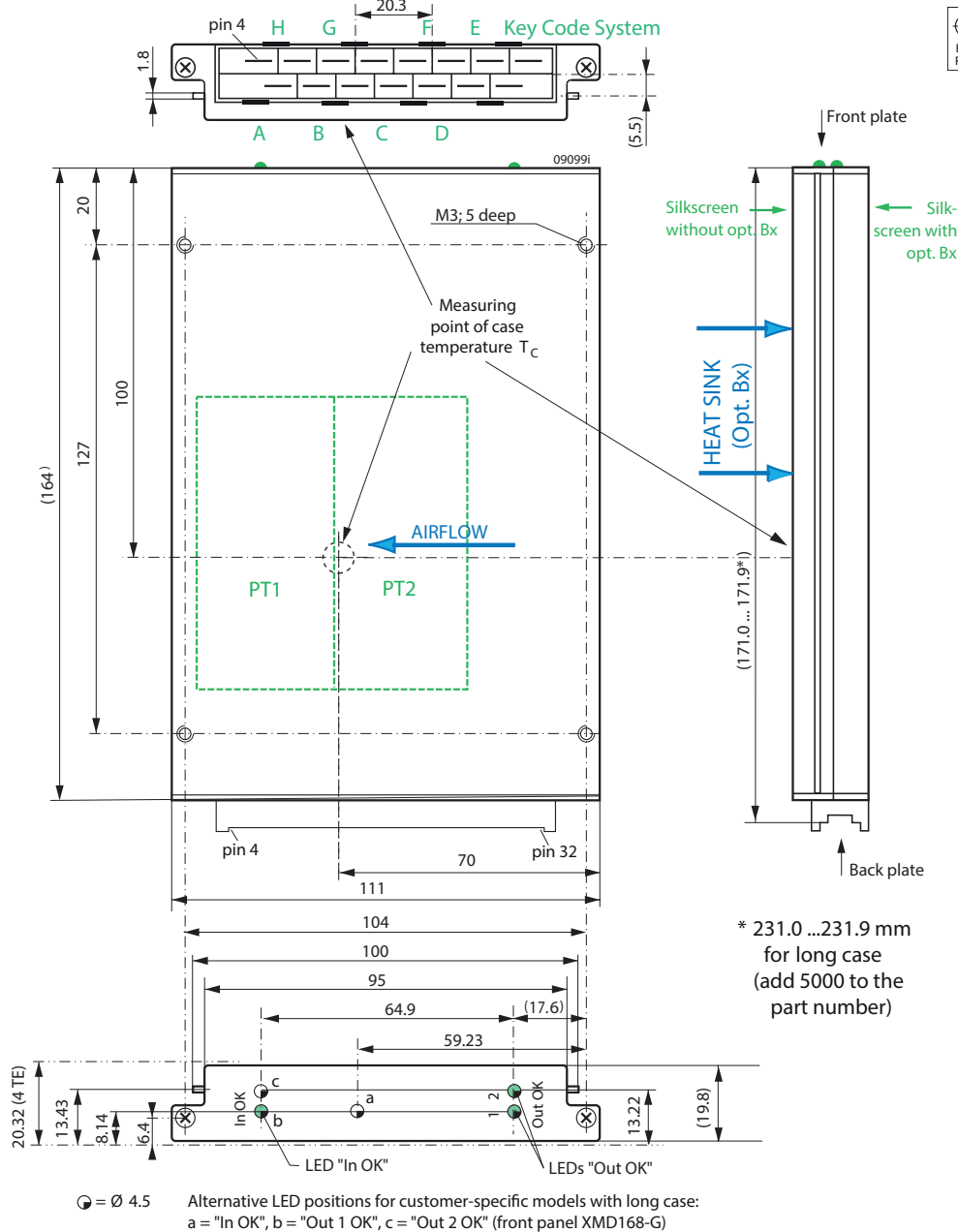

Fig. 23  
Case Q04, weight approx. 500 g  
Aluminum, fully enclosed, black, EP powder coated, self cooling

**Note:** Long case, elongated by 60 mm for a 220 mm rack depth, is available on request: Add 5000 to the part number !

### Safety and Installation Instructions

#### Connector Pin Allocation

The connector pin allocation table defines the electrical potentials and the physical pin positions on the H15 and H15S2 connector. Pin no. 26, protective earth, is a leading pin to ensure that it makes contact with the female connector first.

**Notes:**

- The current through each standard H15 contact depends on the female connector, the ambient temperature and the air flow in the region of the connector. We recommend to limit the mean current to 15 A at 50 °C and to 13 A at 71 °C.
- High currents require a large cross-sectional area of the connections to the female contacts. We recommend solder or screw terminal contacts. Each faston connection exhibits a resistance of typ. 4 mΩ (max. 8 mΩ), which makes it less suitable for high currents.
- For single-output models with option K, both output contacts must always be used and connected in parallel to the load with large cross-sectional area wires or thick copper lands. The efficiency is lower with option K.
- High-current contacts of P1000 models allow for a high output current. Their resistance is only typ. 1 mΩ.

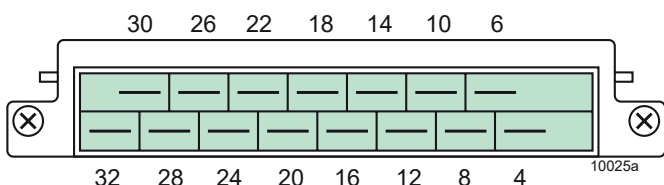

Fig. 24a  
View of male standard H15 connector.  
The Key Code positions are shown in fig. 23.

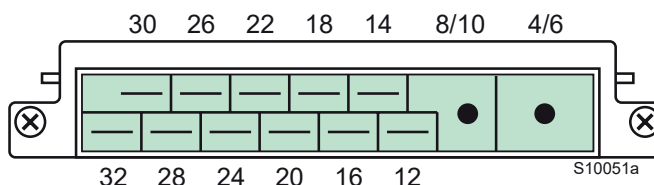

Fig. 24b  
View of male H15S2 connector (with high-current contacts) used in P1000 and P1100 without option K. H15-S2 connectors have no Key Code system.

Table 12: Pin allocation

Pin	P1000		P2000		P3000		P4000	
4 <sup>1</sup>	Vo+	Output 1 pos.	Vo1+	Output 1 pos.	Vo1+	Output 1 pos.	Vo1+	Output 1 pos.
6 <sup>1</sup>	Vo+	Output 1 pos.	Vo2+	Output 2 pos.	Vo2+	Output 2 pos.	Vo2+	Output 2 pos.
8 <sup>2</sup>	Vo-	Output 1 neg.	Vo1-	Output 1 neg.	Vo1-	Output 1 neg.	Vo1-	Output 1 neg. <sup>6</sup>
10 <sup>2</sup>	Vo-	Output 1 neg.	Vo2-	Output 2 neg.	Vo2-	Output 2 neg.	Vo2-	Output 2 neg.
12	S+	Sense +	S1+	Sense 1 +	S1+	Sense 1 +	Vo4+	Output 4 pos.
14	S-	Sense -	S1-	Sense 1 -	S1-	Sense 1 -	Vo4-	Output 4 neg. <sup>6</sup>
16	R	Adjust of $V_o$	R	Adjust of $V_{o1}$	R	Adjust of $V_{o1}$	R	Adjust of $V_{o1/4}$
			T	Current share <sup>3</sup>	T	Current share <sup>3</sup>		
18	T <sup>5</sup>	Current share	S2+	Sense 2 +	Vo3+	Output 3 pos.	Vo3+	Output 3 pos.
20	n.c.	Not connected	S2-	Sense 2 -	Vo3-	Output 3 neg.	Vo3-	Output 3 neg.
22	Out OK+	Out OK + <sup>4</sup>	Out OK+	Out OK + <sup>4</sup>	Out OK+	Out OK + <sup>4</sup>	Out OK+	Out OK + <sup>4</sup>
24	n.c.	Not connected	n.c.	Not connected	n.c.	Not connected	n.c.	Not connected
	Out OK-	Out OK - <sup>4</sup>	Out OK-	Out OK - <sup>4</sup>	Out OK-	Out OK - <sup>4</sup>	Out OK-	Out OK - <sup>4</sup>
26		Prot. earth PE		Prot. earth PE		Prot. earth PE		Prot. earth PE
28	i	Inhibit primary	i	Inhibit primary	i	Inhibit primary	i	Inhibit primary
30	Vi+	Input pos.	Vi+	Input pos.	Vi+	Input pos.	Vi+	Input pos.
32	Vi-	Input neg.	Vi-	Input neg.	Vi-	Input neg.	Vi-	Input neg.

<sup>1</sup> Pin 4/6 (high-current contact) for P1000 models with 3.3 V or 5.1 V output (H15S2 connector, no option K)  
<sup>2</sup> Pin 8/10 (high-current contact) for P1000 models with 3.3 V or 5.1 V output (H15S2 connector, no option K)  
<sup>3</sup> Option T for 3.3 V and 5.1 V powertrains: Only  $I_{o1}$  is influenced  
<sup>4</sup> Not connected, if option D is not fitted.  
<sup>5</sup> Not connected, if option T is not fitted.  
<sup>6</sup> Powertrains with 5.1 V and 3.3 V outputs have a common return: Vo1- and Vo4- are connected together.



### Installation Instructions

These converters are components, intended exclusively for inclusion within other equipment by an industrial assembly process or by a professionally competent person. Installation must strictly follow the national safety regulations in respect of the enclosure, mounting, creepage distances, clearances, markings and segregation requirements of the end-use application.

Connection to the system shall be made via the female connector H15 or H15S2 (see *Accessories*). Other installation methods may not meet the safety requirements. Check for hazardous voltages before altering any connections. Pin 26 (PE) is a leading pin and is reliably connected to the case. For safety reasons it is essential to connect this pin to the protective earth.

The Vi- input (pin 32) is internally fused. This fuse is designed to protect the converter against overcurrent caused by a failure, but may not be able to satisfy all requirements. External fuses in the wiring to one or both input pins (no. 30 and/or no. 32) may therefore be necessary to ensure compliance with local requirements.

**Important:** If the inhibit function is not used, connect pin 28 (i) with pin 32 (Vi-) to enable the output(s).

Do not open the converter, or the warranty will be invalidated. Make sure that there is sufficient airflow available for convection cooling. This should be verified by measuring the case temperature at the specified measuring point, when the converter is operated in the end-use application:  $T_{C\max}$  should not be exceeded. Ensure that a failure of the converter does not result in a hazardous condition; see also *Safety of Operator-Accessible Output Circuits*.

### Standards and Approvals

The P Series converters are safety-approved to the latest edition of IEC/EN 62368-1 and UL/CSA 60950-1.

They have been evaluated for:

- Class I equipment
- Building in
- Double or reinforced insulation based on 250 VAC between input and output and between input and auxiliary circuits
- Overvoltage category II
- Pollution degree 2 environment
- The converters fulfill the requirements of a fire enclosure.

CB-scheme is available (CB 06 07 24238 800).

The converters are subject to manufacturing surveillance in accordance with the above mentioned safety standards and with ISO 9001:2015, IRIS ISO/TS 22163:2017 certified quality and business management system.

### Protection Degree and Cleaning Liquids

The DC-DC converters correspond to protection degree IP 40, provided that the female connector is fitted to the converter. Since the converters are not hermetically sealed. In order to avoid possible damage, any penetration of liquids shall be avoided.

### Railway Applications

The converters have been designed observing the railway standards EN 50155:2017 and EN 50121-3-2:2016. All boards are coated with a protective lacquer.

All models with version V114 (or later, except models with connector H15S2 ) comply with EN 45545, HL1 to HL3. They also comply with NF-F-16, Class I3/F2 (except when operated in a vertical position, i.e. with the connector on top or on bottom).

### Isolation

The electric strength test is performed in the factory as routine test according to EN 62911 and IEC/EN 62368-1. The company will not honor any warranty claims resulting from incorrectly executed electric strength field tests. The resistance of the earth connection to the case ( $< 0.1 \Omega$ ) is tested as well.

Table 14: Isolation

Characteristics		Input to		Outputs to Case	Output to Output <sup>4</sup>	Out OK signals to			Unit
		Outputs <sup>1</sup>	Case + Outputs			Input	Case	Outputs	
Electric strength test	Factory test 10 s	4.2	2.2 / 2.86 <sup>5</sup>	1.0	0.5 / 0.7 <sup>5</sup>	2.2 / 2.86 <sup>5</sup>	1.0	0.5 / 0.7 <sup>5</sup>	KVDC
	AC test voltage equivalent to factory test	3.0	1.5 / 2.0 <sup>5</sup>	0.7	0.35 / 0.5 <sup>5</sup>	1.5 / 2.0 <sup>5</sup>	0.7	0.35 / 0.5 <sup>5</sup>	KVAC
Insulation resistance		>300 <sup>2</sup>	>300 <sup>2</sup>	>300 <sup>2</sup>	>100	>300 <sup>2</sup>	>100	>100	MΩ
Creepage distances		5.0	3.5	1.0					mm

<sup>1</sup> Pretest of subassemblies in accordance with IEC/EN 62368-1

<sup>2</sup> Tested at 500 VDC

<sup>3</sup> Option D

<sup>4</sup> Powertrains with a combined 5.1 / 3.3 V output have a common return.

<sup>5</sup> 2<sup>nd</sup> value valid for models with version V114 (or later)



Asia-Pacific +86 755 298 85888 EMEA +353 61 531 820 North America +1 866 513 2839

powersupport@belf.com  
belfuse.com

**Safety of Operator-Accessible Output Circuits**

If the output circuit of a DC-DC converter is operator accessible, it shall be an ES1 circuit according to the IEC/EN 62368-1 related safety standards.

The following table shows some possible installation configurations, compliance with which causes the output circuit of the DC-DC converter to be an ES1 circuit according to IEC/EN 62368-1 up to a configured output voltage (sum of nominal voltages if in series or +/- configuration) of 35 V.

However, it is the sole responsibility of the installer to ensure the compliance with the relevant and applicable safety regulations.

Use fuses and earth connections as per table below. See also *Installation Instructions*.

Table 15: Safety concept leading to an ES1 output circuit

Conditions	Front end	DC-DC converter	Result
Nominal supply voltage	Minimum required grade of insulation, to be provided by the AC-DC front end, including mains supplied battery charger	Maximum DC output voltage from the front end <sup>1</sup>	Minimum required safety status of the front end output circuit
Mains ≤ 250 VAC	Functional (i.e. there is no need for electrical insulation between the mains supply voltage and the DC-DC converter input circuit)	≤ 168 V	Primary circuit (The nominal voltage between any input pin and earth shall not exceed 250 VAC or 240 VDC.)
	Basic		Earth related hazardous voltage secondary circuit (The nominal voltage between any input pin and earth shall not exceed 250 VAC or 240 VDC.)
			Unearthed hazardous voltage secondary circuit
	Supplementary		Unearthed hazardous voltage secondary circuit <sup>3</sup>
			Measures to achieve the specified safety status of the output circuit
			Safety status of the DC-DC converter output circuit
			ES1 circuit
			Double or reinforced insulation, based on 250 VAC and 240 VDC (provided by the DC-DC converter) and earthed case <sup>2</sup>
			Double or reinforced insulation, based on the maximum nominal output voltage from the front end (both provided by DC-DC converter) and earthed case <sup>2</sup> .
			Supplementary insulation, based on 250 VAC and DC and double or reinforced insulation, based on the maximum nominal output voltage from the front end (both provided by DC-DC converter) and earthed case <sup>2</sup> .
			Basic insulation, based on 250 VAC and DC (provided by the DC-DC converter)

<sup>1</sup> The front end output voltage should match the specified input voltage range of the DC-DC converter. The maximum rated input voltage of EP types is 150 V according to IEC/EN 62368-1.

<sup>2</sup> The earth connection has to be provided by the installer according to the relevant safety standards, e.g., IEC/EN 62368-1.

<sup>3</sup> Has to be insulated from earth by at least supplementary insulation (by the installer) according to the relevant safety standards, e.g. IEC/EN 62368-1, based on the maximum nominal output voltage from the front end. If the converter case is accessible, it has to be earthed or the front end output circuit has to be insulated from the converter case by at least basic insulation, based on the maximum nominal mains supply voltage.

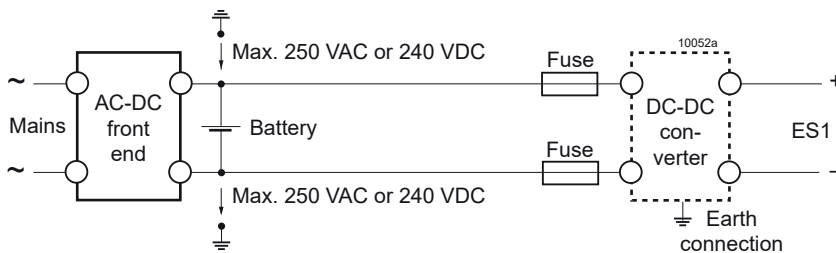

Fig. 25 Schematic safety concept

## Description of Options

### Option D: Out OK Monitor

Option D monitors the state of the output error amplifiers on both power trains rather than the input voltage, output voltage, or the current limit. It signals a fault, when one of the error amplifiers reaches its limit, which means that at least one output voltage is not within its regulation limits. This could occur, because the input voltage is below the minimum level or the load current is too high. This function is not adjustable.

A galvanically isolated open-collector output generates the “Out OK” signal. The circuit monitors simultaneously that

- the input voltage is present and the inhibit signal enables the converter - same logic as LED “In OK”
- the output voltages are within their limits - same logic as LED(s) “Out OK”.

The open collector is conducting, if the monitored conditions are fulfilled.

This option is located on a subassembly allowing special circuit design on customer request.

Dimensioning of resistor value  $R_p \geq \frac{V_p}{50 \text{ mA}}$ .

**Caution:** The Out OK circuit is protected by a Zener diode. To prevent damage, the applied current  $I_{OK}$  should be limited to  $\pm 50 \text{ mA}$ . The Zener diode should not be exposed to more than  $0.25 \text{ W}$ .

Table 16: Output OK data

Characteristics / Conditions	min	typ	max	Unit
$V_{OK}$ Out OK voltage Output good, $I_{OK} < 50 \text{ mA}$	0.8	1.5		V
$I_{OK}$ Out OK current Output out of range, $V_{OK} < 27 \text{ V}^1$		25		$\mu\text{A}$

<sup>1</sup> for version V115 or later.

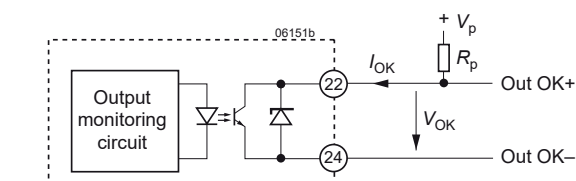

Fig. 26  
Output OK circuit (option D)

### Option T: Active Current Sharing

For 3.3 V and 5.1 V outputs only. The current share facility should be used, when several converters are operated in parallel. Examples could be high reliability n+1 redundant systems or systems providing higher output power.

Using this feature reduces the stress of individual converters and improves the reliability of the system. Interconnection of the current-sharing T-pins causes the converters to share their output currents evenly.

In redundant systems, the outputs of the converters are decoupled by ORing diodes. Consequently, a failure of one converter will not lead to a system failure.

Since the voltage on the T-pin is referenced to the sense pin S-, the installer must ensure that the S- pins of all parallel converters are at the same electrical potential and that there are no voltage drops across the connection lines between these pins.

Double-output converters with outputs connected in series can also be paralleled with current sharing, if pins Vo1- of all converters are connected together; see fig. 10.

If the output voltages of parallel connected single-output converters are programmed to a voltage other than  $V_{o, nom}$  by means of the R pin, the outputs should be adjusted individually within a tolerance of  $\pm 1\%$ .

**Note:** Option T is only available for 3.3 V or 5.1 V single-output power trains and only for output 1.

In double- or triple-output models, option T1 (pin 16) influences only output 1. Then the R-function is not present, since no pin is left for that function.

### Option B0, B1, B3: Heat Sink

The converter is fitted with an additional heat sink.

Table 17: Thermal resistance of the case (approx. values)

Case	Thermal resistance	Thickness of case
Standard, 160 mm long	1.6 K/W	< 20 mm
Case, 220 mm long	1.4 K/W	< 20 mm
Option B0	1.5 K/W	< 30 mm
Option B1	1.4 K/W	< 40 mm
Option B3	1.2 K/W	< 50 mm

<sup>1</sup> Add 5000 to the part number.

### Option G

RoHS compliant for all six substances. Option G should be chosen for new designs.

# P Series

## 90 - 192 W DC-DC Converters



### Accessories

A wide variety of electrical and mechanical accessories are available:

- Mating connectors including faston, screw, solder, or press-fit terminals
- Front panels, system Schroff, for 19" rack 3 U, configuration 4 TE (G04-Q04), 5 TE (G05-Q04), or 6 TE (G06-Q04), including a support angel.
- Front panels system Schroff, for 19" rack 6 U, configuration 5 TE (G05-6HE-Q04)
- Mechanical mounting supports for chassis, DIN-rail, and PCB mounting
- Connector retention brackets HZZ01217-G (CRB-Q)
- Different cable connector housings (cable hoods)



H15 female connector, code key system, faston, screw or other terminals

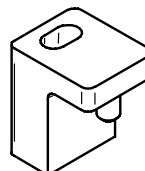

Connector retention bracket HZZ01217-G



Mounting plate Q for wall mounting (HZZ01215-G) with connector retention clips Q (HZZ01229-G)



Universal mounting bracket for DIN-rail and chassis mounting (HZZ00610-G).



Front panel kit G05-6HE-Q01 (HZZ00838) accommodating two HP units for a 19" DIN-rack with 6 U, 5 TE.

For additional information, see the accessory data sheets listed with each product series or individual model at our website.

**NUCLEAR AND MEDICAL APPLICATIONS** - These products are not designed or intended for use as critical components in life support systems, equipment used in hazardous environments, or nuclear control systems.

**TECHNICAL REVISIONS** - The appearance of products, including safety agency certifications pictured on labels, may change depending on the date manufactured. Specifications are subject to change without notice.



Asia-Pacific +86 755 298 85888 EMEA +353 61 531 820 North America +1 866 513 2839  
 powersupport@belf.com  
 belfuse.com