

# LDC120 Series

## 120 W AC-DC DIN Rail Switching Power Supply

LDC120 Series is a single phase high performance ultra compact DIN Rail Power Supply with active PFC, ideal for many applications.

Its compact size, high efficiency, excellent reliability together with easy installation makes it ideal for various industrial applications.

LDC120 Series is Class I isolation device suitable for SELV and PELV circuitry and is designed to be mounted on DIN rail and installed inside a protective enclosure.



### FEATURES

- Input voltage 90 - 264 VAC or 110 - 345 VDC
- Output voltage 24 V, 48 V (adjustable)
- Operating ambient temperature range -35°C to +70°C (up to 60°C with no derating)
- Efficiency up to 90%
- Active PFC
- Overload 150%
- Constant Current or Hiccup mode limitation (user settable)
- Easy parallelable for power increase
- Includes models with internal ORing
- Extremely compact size in aluminum enclosure
- Dimensions: 35 x 103 x 104 mm



### APPLICATIONS

- Industrial control equipment
- Communication
- Instrumentation Equipment

## 1. MODEL SELECTION

MODEL	INPUT VOLTAGE RANGE	OUTPUT VOLTAGE	MAX OUTPUT CURRENT	EFFICIENCY	REDUNDANCY	MAX OUTPUT POWER
LDC120-24	120 - 240 VAC (110 - 345 VDC)	24 V	5.0 A	90 %		120 W
LDC120-24P	120 - 240 VAC (110 - 345 VDC)	24 V	5.0 A	89 %	Internal ORing diode	120 W
LDC120-48	120 - 240 VAC (110 - 345 VDC)	48 V	2.5 A	90 %		120 W
LDC120-48P	120 - 240 VAC (110 - 345 VDC)	48 V	2.5 A	89 %	Internal ORing diode	120 W

## 2. INPUT SPECIFICATIONS

PARAMETER	DESCRIPTION / CONDITIONS	SPECIFICATION
AC Input Voltage	Nominal (UL certified) Range	100 - 240 VAC 90 - 264 VAC
DC Input Voltage		110 - 345 VDC
Input Frequency		47 - 63 Hz
AC Input Current	V <sub>in</sub> = 120 VAC V <sub>in</sub> = 240 VAC	1.4 A 0.7 A
DC Input Current	V <sub>in</sub> = 110 VDC V <sub>in</sub> = 345 VDC	1.4 A 0.5 A
Power Factor Correction	Active	> 0.9
Inrush Peak Current I <sub>pt</sub>	Peak Current measured after 0.2 ms from main connection; 240 VAC / 50 Hz; T <sub>a</sub> = 25°C; Cold Start	≤ 32 A 0.49 A <sup>2</sup> s
Touch (Leakage) Current		≤ 0.5 mA
Internal Protection Fuse	Not user replaceable	3.15 AT
Recommended External Protection	It is strongly recommended to provide external surge arresters (SPD) according to local regulations.	Fuse 4 AT or MCB 4 A C curve

## 3. OUTPUT SPECIFICATIONS

PARAMETER	DESCRIPTION / CONDITIONS	SPECIFICATION
Output Voltage (Adjustable)	24 V models 48 V models	11.5 - 29 VDC 23 - 56 VDC
Output Current (continuous)	24 V models 48 V models	5 A 2.5 A
Load Regulation	LDC120-24 LDC120-24P LDC120-48 LDC120-48P	≤ 1 % ≤ 3 % ≤ 0.5 % ≤ 1.5 %
Ripple & Noise	20 MHz BW probe terminated with a 0.1 μF MKP parallel capacitor	≤ 60 mVpp
Hold-up Time	V <sub>in</sub> = 120 VAC V <sub>in</sub> = 240 VAC	≥ 20 ms ≥ 30 ms
Status Signals	DC OK - green LED OVERLOAD - red LED DC OK - dry contact (NO, 24 VDC / 1 A)	
Parallel connection <sup>1</sup>	Possible for power or redundancy (with external ORing module) P models - include internal ORing diode	

<sup>1</sup> Pay attention, set the current limitation mode jumper on C.C. mode when connecting more units in parallel.

## 4. PROTECTIONS

PARAMETER	DESCRIPTION / CONDITIONS	SPECIFICATION
Short circuit protection	Constant current or Hiccup mode (user settable)	
Overload protection	Constant current Overload limit (user settable)	24 V models 48 V models
	Hiccup mode Overload limit (max. 5 s) (user settable)	24 V models 48 V models
Thermal protection		
Input under voltage lockout		
Over voltage protection		24 V models 48 V models
		≥ 33 VDC ≥ 68 VDC

## 5. ENVIRONMENTAL, EMC & SAFETY SPECIFICATIONS

PARAMETER	DESCRIPTION / CONDITIONS	SPECIFICATION
Operating Temperature	UL certified up to 60°C Start-up type tested: - 35°C, possible at Vnom with load deration.	-35 to +70 °C
Storage Temperature		-40 to +80 °C
Derating	Over 60°C	- 1.2 W/°C
Dissipated Power	LDC120-24 / LDC120-48	< 13.5 W
	LDC120-24P / LDC120-48P	< 15.0 W
Humidity	Non-condensing	5 - 95 % RH
Life Time Expectancy	Ta = 25°C, full load	74 640 (8.5) hrs (years)
MTBF	MIL-HDBK-217F at Ta = 25°C, full load	> 500 000 hrs
Overvoltage Category	EN 50178	III
Pollution Degree	IEC 60664-1	2
Protection Class	Class I	
Isolation	Input to Output	4.2 kVDC
	Input to Ground	2.2 kVDC
	Output to Ground	0.75 kVDC
Safety Standards & Approvals	UL 508	
	IEC/EN 61010-1	
	IEC/EN 61010-2-201	
	IEC/EN 60950	
EMC Emissions	EN 55011 / CISPR 11	Class B
	EN 61000-3-2	Class A
EMC Immunity	EN 61000-4-2	Level 3
	EN 61000-4-3	Level 3
	EN 61000-4-4	Level 4
	EN 61000-4-5	Level 4
	EN 61000-4-11	Level 2
Protection Degree	EN 60529	IP20
Vibration Sinusoidal	IEC 60068-2-6	5-17.8 Hz: ±1.6 mm; 17.8-500 Hz: 2 g 2 Hours / axis (X,Y,Z)
Shock	IEC 60068-2-27	30 g 6 ms, 20 g 11 ms; 3 bumps / direction, 18 bumps total

## 6. MECHANICAL SPECIFICATIONS

PARAMETER	DESCRIPTION / CONDITIONS	SPECIFICATION
Dimensions		35 x 103 x 104 mm
		1.38 x 4.05 x 4.09 in
Weight		450 g
Mounting Rail	IEC 60715/H15/TH35-7.5(-15)	
Connection Terminals	Screw type pluggable (24 - 12 AWG)	2.5 mm <sup>2</sup>
Case Material	Aluminum	

### 7. PIN LAYOUT & DESCRIPTION

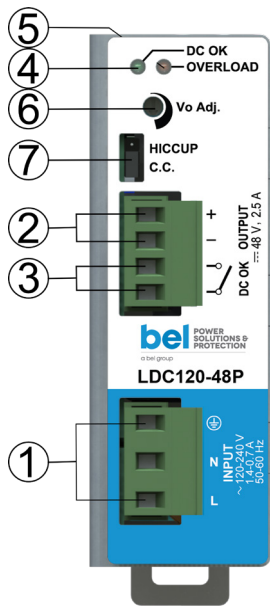

PIN	DESCRIPTION
1	AC/DC input
2	DC output (load)
3	Diagnostic Output (dry contact, NC output OK)
4	Green LED: Output OK
5	Red LED: Overload
6	Output voltage adjustment
7	Selectable limitation mode (Hiccup mode, C.C. mode)

INPUT CONNECTION	Single phase	DC Input
	L = Line	L = + Positive DC
	N = Neutral	N = - Negative DC
	⊕ = Earth ground	⊕ = Earth ground

OUTPUT CONNECTION	
	+ = Positive DC
	- = Negative DC

SIGNALLING	
	DC OK: dry contact
	• NO
	• COM

### 8. MECHANICAL DRAWING

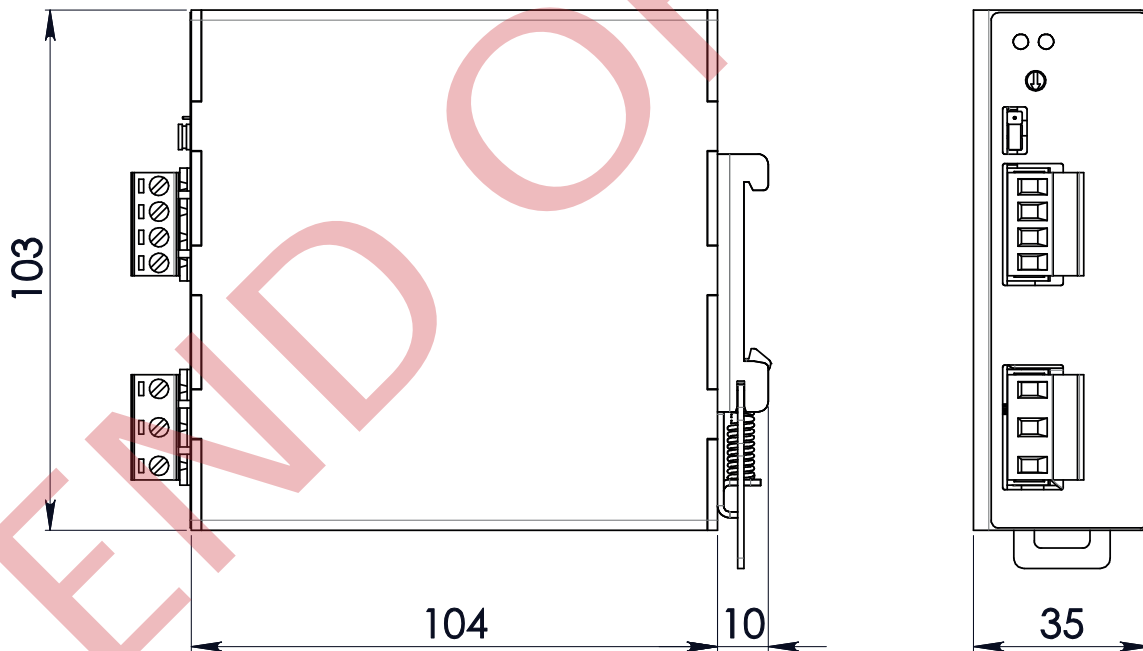

Figure 1. Mechanical Drawing

**Notes:**

Technical parameters are typical, measured in laboratory environment at 25°C and 240 VAC / 50 Hz, at nominal values, after minimum 5 minutes of operation. Power rating, losses, efficiency, ripple, thermal behaviour and start-up may change outside of the nominal rated input range. Contact factory for details.

**NUCLEAR AND MEDICAL APPLICATIONS** - Products are not designed or intended for use as critical components in life support systems, equipment used in hazardous environments, or nuclear control systems.

**TECHNICAL REVISIONS** - The appearance of products, including safety agency certifications pictured on labels, may change depending on the date manufactured. Specifications are subject to change without notice.



Asia-Pacific  
+86 755 298 85888

EMEA  
+353 61 49 8941

North America  
+1 866 513 2839

[belfuse.com/power-solutions](http://belfuse.com/power-solutions)