

Powerline Modules

500Mbps Modules

The Single In-line Package (SIP) module is an IEEE1901 and HomePlug AV based MAC/PHY/AFE Powerline Communications (PLC) transceiver/modem.

The Module provides an integrated solution for Powerline communications. The “Black Box” design requires no external software and only a few external components to create a working solution. Operate as a PHY or MAC is selectable via Pull up/down resistor.

Communication is possible over any 2 wire system DC/AC or Dry wire.

Key Features & Benefits

- Based on Qualcomm Atheros AR7410/AR1500 chipset
- Industrial Temperature Range -40°C – +85°C
- Supports IEEE1901 HomePlug® AV Standard with data rates of 500Mbps
- RGMII (0804-5000□50) or MII (0804-5000□51) (Host & PHY) interface
- Supports 4096/1024/256/64/16/8-QAM, QPSK, BPSK and ROBO modulation schemes
- 128-bit AES Link Encryption with key management for secure power line communications
- Windowed OFDM with noise mitigation based on patented line synchronization techniques improves data integrity in noisy conditions
- Dynamic channel adaptation and channel estimation maximizes throughput in harsh channel conditions
- Horizontal mounting configuration using standard 1.27mm pin header (50 way)
- Integrates core components necessary to add HomePlug AV functionality to any embedded system at low cost
- Designed to meet Class A conducted emissions EMC standards for industrial applications
- 0804-5000□51 offers a MII interface and is compatible with the existing 0804-5000-18/24 Modules

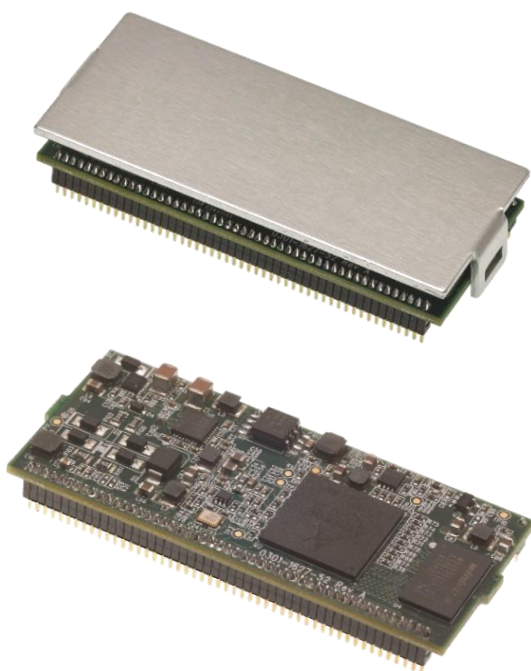

Models

Part Number	Temp Range	Interface	Market
0804-5000A50	-40°C – +85°C Including Heatsink	RGMII	US
0804-5000A51	-40°C – +85°C Including Heatsink	MII (0804-5000-18/24 compatible)	US
0804-5000E50	-40°C – +85°C Including Heatsink	RGMII	EU
0804-5000E51	-40°C – +85°C Including Heatsink	MII (0804-5000-18/24 compatible)	EU

Powerline Modules

500Mbps Module

Module Block Diagram

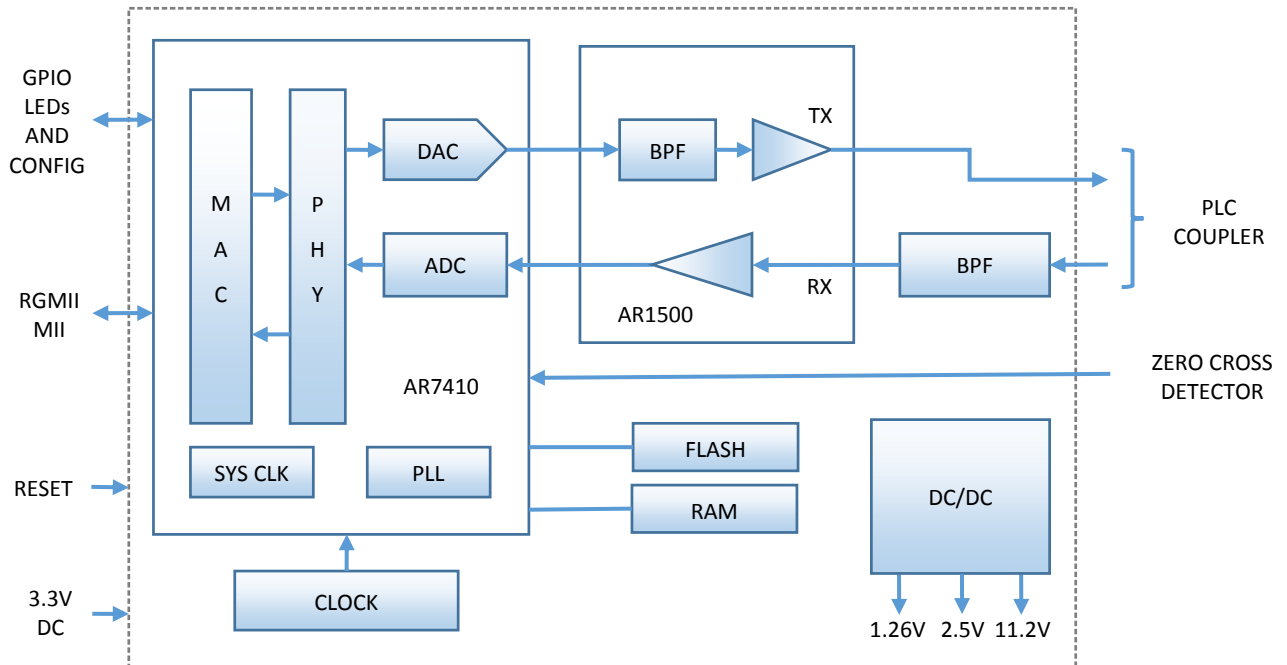

* Dotted line signifies Modules External connectivity.

System Block Diagram

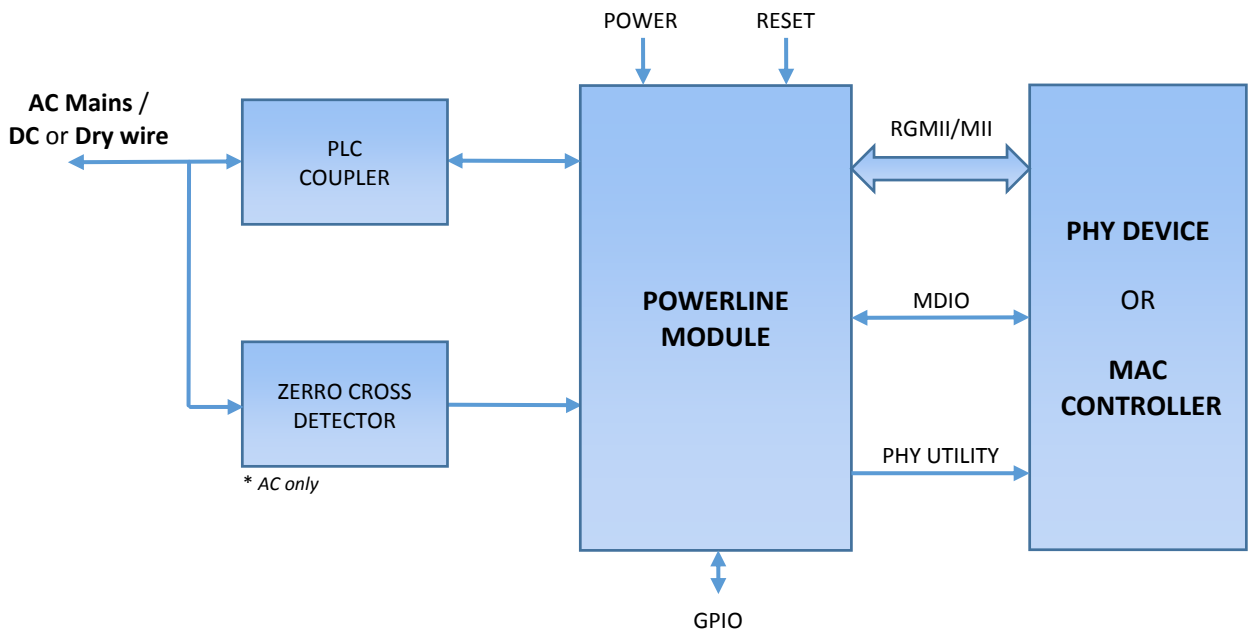

The block diagram presents the Powerline module in a typical environment.

Powerline Modules

500Mbps Module

Module Interface

Module connectivity is provided via a 50 way 1.27mm pitch gold pin header.

Pin Number	Pin Name MII	RGMII	Type	Description
1	VDD		PWR	+3.3V
2	VSS		PWR	Ground
3	VDD		PWR	+3.3V
4	VSS		PWR	Ground
5	VNET_IO		PWR	+2.5V / +3.3V
6	TXRX+		I/O	Differential TXRX signal, connects to coupling transformer
7	TXRX-		I/O	Differential TXRX signal, connects to coupling transformer
8	VSS		PWR	Ground
9	RESERVED ^[1]		-	Reserved pin
10	RESERVED ^[1]		-	Reserved pin
11	RESET#		I	Resets all IC logic when low
12	GPIO0		I/O	Strap: ENET_SEL[0]
13	GPIO1		I/O	Strap: ENET_SEL[1]; Push-button: Simple connect
14	GPIO2		I/O	Strap: ANEN; Push-button: Factory default
15	RESERVED ^[1]		-	Reserved pin
16	GPIO4		I/O	Strap: SPEED_SEL[0]
17	GPIO5		I/O	Strap: MD_A3
18	GPIO6		I/O	Strap: CFG_SEL
19	GPIO7		I/O	Strap: MD_A4
20	GPIO8		I/O	Strap: MP_SEL; LED: Powerline Tx/Rx Link
21	GPIO3		I/O	Strap: ISODEF; LED: Ethernet Tx/Rx Link
22	GPIO10		I/O	Strap: BM_SEL
23	GPIO11		I/O	Strap: SPEED_SEL[1]; LED: Power
24	ZC_IN		I/O	Zero-cross detection signal
25	MDIO		I/O	Management Data Interface Data Line
26	MDC		O _{MAC} /I _{PHY}	Management Data Interface Clock Line
27	RESERVED ^[1]		-	Reserved pin
28	RESERVED ^[1]		-	Reserved pin
29	VSS		PWR	Ground
30	MRX_D0	RD0	I _{MAC} /O _{PHY}	MII / RGMII: Receive Data Bits (MAC)
31	MRX_D1	RD1	I _{MAC} /O _{PHY}	MII / RGMII: Receive Data Bits (MAC)
32	MRX_D2	RD2	I _{MAC} /O _{PHY}	MII / RGMII: Receive Data Bits (MAC)
33	MRX_D3	RD3	I _{MAC} /O _{PHY}	MII / RGMII: Receive Data Bits (MAC)
34	COL	RESERVED ^[2]	I _{MAC} /O _{PHY}	MII: Collision Detected
35	MRX_CLK	RXC	I _{MAC} /O _{PHY}	MII / RGMII: Receive Clock (MAC)

Powerline Modules

500Mbps Module

Pin Number	Pin Name	MII	RGMII	Type	Description
36	VSS			PWR	Ground
37	MRX_ERR		RESERVED [2]	I _{MAC} /O _{PHY}	MII: Receive Error (MAC)
38	MRX_DV		RX_CTL	I _{MAC} /O _{PHY}	MII: Receive Data Valid (MAC) RGMII: Receive control signal (MAC)
39	MTX_D0		TD0	O _{MAC} /I _{PHY}	MII / RGMII: Transmit Data Bits (MAC)
40	MTX_D1		TD1	O _{MAC} /I _{PHY}	MII / RGMII: Transmit Data Bits (MAC)
41	MTX_D2		TD2	O _{MAC} /I _{PHY}	MII / RGMII: Transmit Data Bits (MAC)
42	MTX_D3		TD3	O _{MAC} /I _{PHY}	MII / RGMII: Transmit Data Bits (MAC)
43	CRS		RESERVED [2]	I _{MAC} /O _{PHY}	MII: Carrier Sense
44	MTX_CLK		TXC	MII: I _{MAC} /O _{PHY} RGMII: O _{MAC} /I _{PHY}	MII: Transmit Clock (MAC) RGMII: Transmit Clock (MAC)
45	MTX_EN		TX_CTL	O _{MAC} /I _{PHY}	MII: Transmit Enable (MAC) RGMII: Transmit Control Signal (MAC)
46	VSS			PWR	Ground
47	PHY_RST#			O	Reset Ethernet PHY
48	VSS			PWR	Ground
49	PHY_CLK			O	Strap: DUPLEX; 25MHz Clock for Ethernet PHY
50	VSS			PWR	Ground

[1] Leave reserved pins disconnected

[2] Add pull down 10kΩ resistor

Ethernet interface

The Ethernet interface can be configured in MAC or PHY mode and depending on the module model either MII or RGMII protocols are supported.

- MAC or PHY mode
- RGMII (0804-5000□50) or MII (0804-5000□51) protocol

In MAC mode, the SIP is configured to be an Ethernet MAC and to communicate to an external Ethernet PHY device. This configuration is typical in an Ethernet Wall Adapter application. In PHY mode, the SIP is configured to be a Physical Medium Dependent (PMD) or PHY controller. In this configuration, an external MAC controls the SIP; this configuration is typical in an embedded application, such as a set-top box. Regardless of which mode is used, the SIP can be configured to use one of below protocols:

- MII (100 Mbps max) Complies with 802.3(u)
- RGMII (1000 Mbps max) Supports RGMII v1.3 with internal 2ns delays

The MAC and PHY configurations support 10 and 100 Mbps in half and full-duplex, and 1000 Mbps in full duplex mode only. When the RGMII interface is used, regardless of the speed, only full-duplex is supported. Flow control is supported in half-duplex using “back-pressure” preamble assertion, and using pause packets in full-duplex mode. The Ethernet interface includes the management data interface for MAC and PHY controller functions. The Ethernet MAC module implements a standard Ethernet MAC function. The Ethernet MAC will be connected to an external Ethernet PHY function. The MAC configuration provides bridging between Ethernet and PLC. The PHY configuration emulates Ethernet PHY functionality and provides PLC connectivity to devices designed to communicate over an Ethernet physical network.

The Ethernet interface has separate transmit and receive packet buffering. When operating as a MAC the transmit FIFO is 2 KB and the receive FIFO is 16 KB. When operating as a PHY controller, the transmit FIFO is 16 KB and the receive FIFO is 2 KB.

Powerline Modules

500Mbps Module

MII Bus Signals

Pin Number	Pin Name	I/O MAC Mode	PHY Mode	Description
30	MRX_D0	I	O	Transmit Data Bits. The PHY controller drives MRX_D[3:0] and the MAC core receives MRX_D[3:0]. MRX_D[3:0] transition synchronously with respect to MRX_CLK. For each MRX_CLK period in which MRX_DV is asserted, MRX_D[3:0] is valid. MRX_D0 is the least-significant bit. The PHY controller tri-states MRX_D[3:0] in isolate mode.
31	MRX_D1			
32	MRX_D2			
33	MRX_D3			
34	COL	I	O	Collision Detected. The PHY controller asserts COL when it detects a collision on the medium. COL remains asserted while the collision condition persists. COL signal transitions are not synchronous to either the MTX_CLK or the MRX_CLK. The MAC core ignores the COL signal when operating in the full-duplex mode. The PHY controller tri-states COL in isolate mode.
35	MRX_CLK	I	O	Receive Clock. MRX_CLK is a continuous clock that provides the timing reference for the transfer of the MRX_DV and MRX_D[3:0] signals from the PHY controller to the MAC core. The PHY controller sources MRX_CLK. MRX_CLK frequency is equal to 25% of the data rate of the received signal on the Ethernet cable. The PHY controller tri-states MRX_CLK in isolate mode.
37	MRX_ERR	I	O	Receive Error. The PHY controller asserts MRX_ERR high for one or more MRX_CLK periods to indicate to the MAC core that an error (a coding error or any error that the PHY is capable of detecting that is otherwise undetectable by the MAC) was detected somewhere in the current frame. MRX_ERR transitions synchronously with respect to MRX_CLK. While MRX_DV is de-asserted, MRX_ERR has no effect on the MAC core. The PHY controller tri-states MRX_ERR in isolate mode.
38	MRX_DV	I	O	Receive Data Valid. The PHY controller asserts MRX_DV to indicate to the MAC core that it is presenting the recovered and decoded data bits on MRX_D[3:0] and that the data on MRX_D[3:0] is synchronous to MRX_CLK. MRX_DV transitions synchronously with respect to MRX_CLK. MRX_DV remains asserted continuously from the first recovered nibble of the frame through the final recovered nibble, and is de-asserted prior to the first MRX_CLK that follows the final nibble. The PHY controller tri-states MRX_DV in isolate mode.
39	MTX_D0	O	I	Transmit Data Bits. The MAC core drives MTX_D[3:0] and the PHY controller receives MTX_D[3:0]. MTX_D[3:0] transitions synchronously with respect to MTX_CLK. For each MTX_CLK period in which MTX_EN is asserted, MTX_D[3:0] is valid. MTX_D0 is the least-significant bit. The PHY controller ignores MTX_D[3:0] in isolate mode.
40	MTX_D1			
41	MTX_D2			
42	MTX_D3			
43	CRS	I	O	Carrier Sense. The PHY controller asserts CRS when either transmit or receive medium is non-idle. The PHY de-asserts CRS when both transmit and receive medium are idle. The PHY must ensure that CRS remains asserted throughout the duration of a collision condition. The transitions on the CRS signal are not synchronous to either the MTX_CLK or the MRX_CLK. The PHY controller tri-states CRS in isolate mode.
44	MTX_CLK	I	O	Transmit Clock. MTX_CLK is a continuous clock that provides a timing reference for the transfer of the MTX_EN and MTX_D[3:0] signals from the MAC core to the PHY controller. The PHY controller sources MTX_CLK. The operating frequency of MTX_CLK is 25 MHz when operating at 100 Mbps and 2.5 MHz when operating at 10 Mbps. The PHY controller tri-states MTX_CLK in isolate mode.
45	MTX_EN	O	I	Transmit Enable. A high assertion on MTX_EN indicates that the MAC core is presenting nibbles to the PHY controller for transmission. The SIP MAC core asserts MTX_EN with the first nibble of the preamble and keeps MTX_EN asserted while all nibbles to be transmitted are presented to the MII. MTX_EN is de-asserted prior to the first MTX_CLK following the final nibble of the frame. MTX_EN transitions synchronously with respect to MTX_CLK. The PHY controller ignores MTX_EN in isolate mode.

Powerline Modules

500Mbps Module

RGMII Bus Signals

Pin Number	Pin Name	I/O MAC Mode	PHY Mode	Description
30	RD0	I	O	Transmit Data Bits. The PHY controller drives RD[3:0] and the MAC core receives RD[3:0]. The Signals contains the bits 3:0 on rising and 7:4 on falling edges of the RXC. The PHY controller tri-states RD[3:0] in isolate mode.
31	RD1			
32	RD2			
33	RD3			
35	RXC	I	O	Receive Clock. RXC is a continuous double data rate (DDR) clock that provides the timing reference for the transfer of the RX_CTL and RD[3:0] signals from the PHY controller to the MAC core. RXC frequency is equal to 25% of the data rate of the received signal on the Ethernet cable in 10/100 Mbps mode, and 12.5% of the data rate of the received signal on the Ethernet cable in 1000 Mbps mode. The PHY controller tri-states RXC in isolate mode.
38	RX_CTL	I	O	Receive Data Valid. RX_CTL is driven by the PHY controller. Contains the RXDV on rising and RXERR on falling edges of the RXC. The PHY controller tri-states RX_CTL in isolate mode.
39	TD0	O	I	Transmit Data Bits. The MAC core drives TD[3:0] and the PHY controller receives TD[3:0]. The Signals contains the bits 3:0 on rising and 7:4 on falling edges of the TXC. The PHY controller tri-states RD[3:0] in isolate mode.
40	TD1			
41	TD2			
42	TD3			
44	TXC	O	I	Transmit Clock. TXC is a continuous double data rate (DDR) clock that provides a timing reference for the transfer of the TX_CTL and TD[3:0] signals from the MAC core to the PHY controller. The operating frequency of TXC is 125 MHz when operating at 1000 Mbps, 25 MHz when operating at 100 Mbps and 2.5 MHz when operating at 10 Mbps. The PHY controller tri-states TXC in isolate mode.
45	TX_CTL	O	I	Transmit Control Signal. TX_CTL is drives by the MAC core. Contains the TXEN on rising and a logical derivative of TXEN and TXERR on falling edges of the TXC. The PHY controller tri-states TX_CTL in isolate mode.

Management Data Interface (MDI)

The Ethernet interface has a two-wire bi-directional serial Management Data Interface (MDI). This interface provides access to the status and control registers in the Ethernet PHY logic.

Pin Number	Pin Name	I/O MAC Mode	PHY Mode	Description
25	MDIO	I/O	I/O	MII Management Data In/Out. This is the data input signal from the PHY controller. The PHY drives the Read Data synchronously with respect to the MDC clock during the read cycles. This is also the data output signal from the MAC core that drives the control information during the Read/Write cycles to the PHY controller. The MAC core drives the MDO signal synchronously with respect to the MDC.
26	MDC	O	I/O	MII Management Data Clock. The MAC core sources MDC as the timing reference for transfer of information on the MDI/MDO signals. MDC signal has no maximum high or low times. MDC minimum high and low times are 160 ns each, and the minimum period for MDC is 400 ns.

Powerline Modules

500Mbps Module

Ethernet Options

The MP_SEL strap is used to specify which mode PHY or MAC the module operates in. The encoding of this signal is shown in the following table:

MP_SEL	Mode
0	PHY mode
1	MAC mode

ENET_SEL[1:0]	MII/RGMII
00	10/100/1000 RGMII No Rx Clk Delay <i>(0804-5000□50 ONLY)</i>
01	10/100/1000 RGMII 2ns Rx Clk Delay <i>(0804-5000□50 ONLY)</i>
10	Not Used
11	10/100 MII <i>(0804-5000□51 ONLY)</i>

In PHY mode, there are 5 additional configuration straps that are unique to this mode of operation:

SPEED_SEL[1:0]	MII/RGMII Speed
00	10Mbps
01	100Mbps
10	1000Mbps (0804-5000□50 ONLY)
11	Reserved

MD_A[4:3]	Management Address
00	0x00
01	0x08
10	0x10
11	0x18

ISODEF	Isolation
0	Normal Operation
1	Isolated

ANEN	Negotiation Mode
0	Auto-Negotiate Disabled
1	Auto-Negotiate Enabled

DUPLEX	MII Duplex
0	Half Duplex
1	Full Duplex

Powerline Modules

500Mbps Module

RGMII and MII Interface Timing Parameters

MII Tx Bus (MTX) and Rx Bus (MRX) Timing Parameter		Min	Max	Units
t_{CLKp}	CLK Period (100 Mb/s, 10 Mb/s)	40/400	-	ns
t_{CLKhi}	CLK High Time (100 Mb/s, 10 Mb/s)	14/140	26/260	ns
t_{CLKlo}	CLK Low Time (100 Mb/s, 10 Mb/s)	14/140	26/260	ns
t_{OV}	Output Valid Time All MTX Signals	10	28	ns
t_{SU}	Input Set Up Time All MRX Signals	10	-	ns
t_{H}	Input Hold Time All MRX Signals	10	-	ns

Management Data Interface Clock (MDC) and Data (MDIO) Timing Parameter		Min	Max	Units
t_{MDCp}	MDC Period (100 Mb/s, 10 Mb/s)	400	-	ns
t_{MDCchi}	MDC High Time (100 Mb/s, 10 Mb/s)	150	-	ns
t_{MDClo}	MDC Low Time (100 Mb/s, 10 Mb/s)	150	-	ns
t_{MOV}	Output Valid MDIO	0	300	ns
t_{MSU}	Input Set Up Time MDIO	10	-	ns
t_{MH}	Input Hold Time MDIO	10	-	ns

Table 1 MII Timing Specification MAC Mode

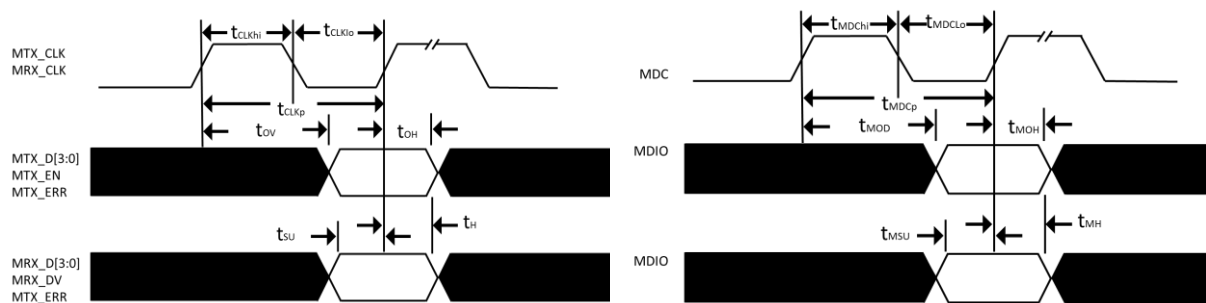

Powerline Modules

500Mbps Module

MII Tx Bus (MTX) and Rx Bus (MRX) Timing		Min	Max	Units
t_{CLKp}	CLK Period (100 Mb/s, 10 Mb/s)	40/400	-	ns
t_{CLKhi}	CLK High Time (100 Mb/s, 10 Mb/s)	14/140	26/260	ns
t_{CLKlo}	CLK Low Time (100 Mb/s, 10 Mb/s)	14/140	26/260	ns
t_{OV}	Output Valid Time All MTX Signals	-	25	ns
t_{OH}	Output Hold Time All MRXR Signals	-	10	ns
t_{SU}	Input Set Up Time All MRX Signals	10	-	ns
t_H	Input Hold Time All MRX Signals	10	-	ns

Management Data Interface Clock (MDC) and Data (MDIO) Timing		Min	Max	Units
t_{MDCp}	MDC Period (100 Mb/s, 10 Mb/s)	400	-	ns
t_{MDChi}	MDC High Time (100 Mb/s, 10 Mb/s)	150	-	ns
t_{MDClO}	MDC Low Time (100 Mb/s, 10 Mb/s)	150	-	ns
t_{MOV}	Output Valid MDIO	0	300	ns
t_{MSU}	Input Set Up Time MDIO	10	-	ns
t_{MH}	Input Hold Time MDIO	10	-	ns

Table 2 MII Timing Specification PHY Mode

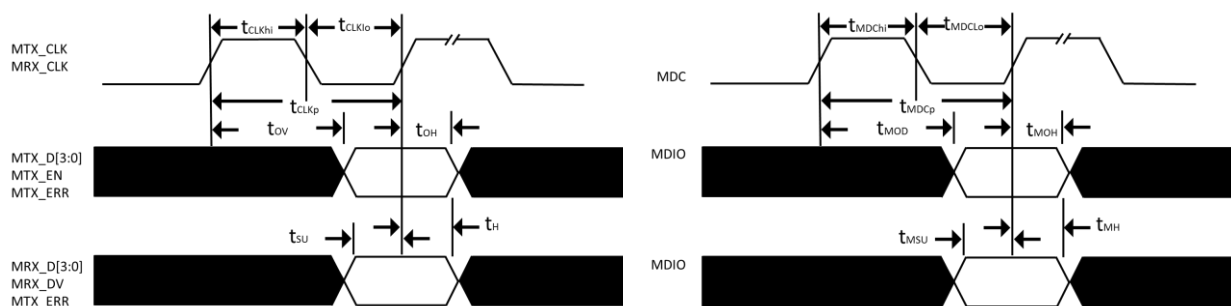

Powerline Modules

500Mbps Module

Symbol	Parameter	Min	Typ	Max	Units
T_{skewT}	Data to Clock output Skew (at Transmitter)	-500	0	500	ps
T_{skewR}	Data to Clock input Skew (at Receiver)	1.0	1.8	2.6	ns
T_{setupT}	Data to Clock output Setup (at Transmitter - integrated delay)	1.2	2.0	-	ns
T_{holdT}	Clock to Data output Hold (at Transmitter - integrated delay)	1.2	2.0	-	ns
T_{setupR}	Data to Clock input Setup (at Receiver - integrated delay)	1.0	2.0	-	ns
T_{holdR}	Data to Clock input Setup (at Receiver - integrated delay)	1.0	2.0	-	ns
T_{cyc}	Clock Cycle Duration ^[1]	7.2	8	8.8	ns
Duty_G	Duty Cycle for Gigabit	45	50	55	%
Duty_T	Duty Cycle for 10/100T	40	50	60	%
Tr/Tf	Rise/Fall Time (20% to 80%)	-	-	0.75	ns

[1] For 10/100/1000T operation, TXC and RXC will be 2.5 MHz, 25 MHz and 125 MHz respectively.

Table 3 RGMII-ID MAC Mode Timing Specification

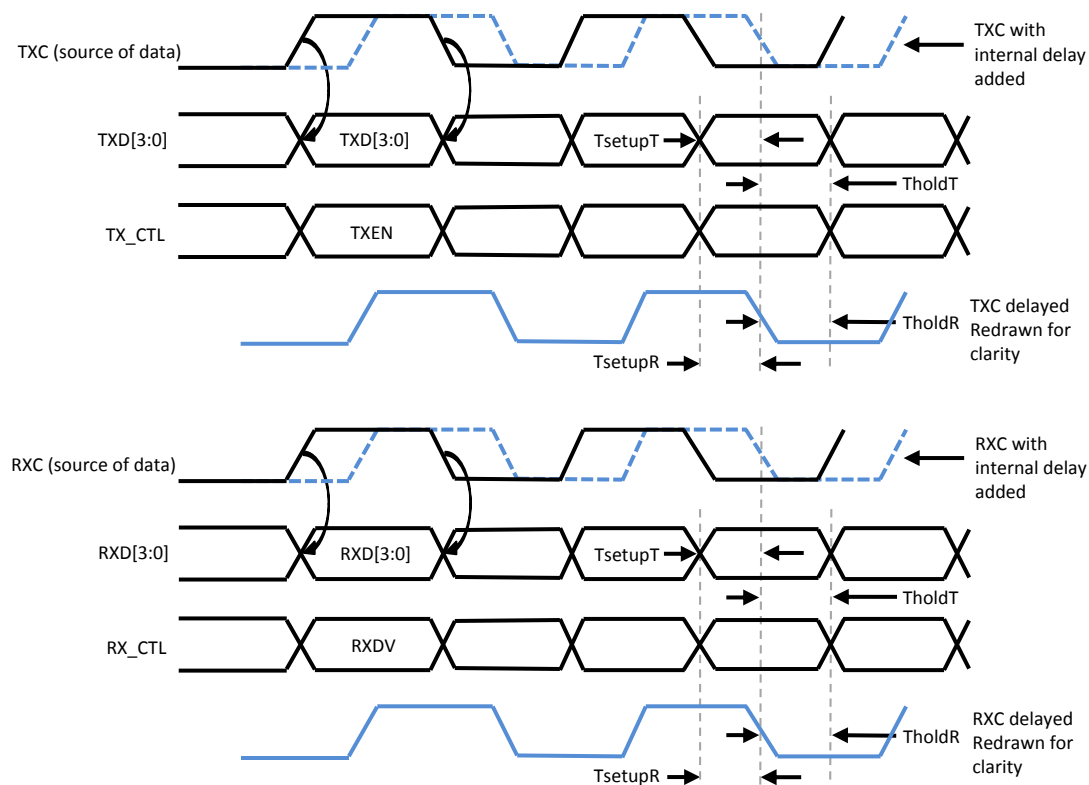

Powerline Modules

500Mbps Module

Symbol	Parameter	Min	Typ	Max	Units
T_{skewT}	Data to Clock output Skew (at Transmitter)	-500	0	500	ps
T_{skewR}	Data to Clock input Skew (at Receiver)	1.0	1.8	2.6	ns
T_{setupT}	Data to Clock output Setup (at Transmitter - integrated delay)	1.2	2.0	-	ns
T_{holdT}	Clock to Data output Hold (at Transmitter - integrated delay)	1.2	2.0	-	ns
T_{setupR}	Data to Clock input Setup (at Receiver - integrated delay)	1.0	2.0	-	ns
T_{holdR}	Data to Clock input Setup (at Receiver - integrated delay)	1.0	2.0	-	ns
T_{cyc}	Clock Cycle Duration ^[1]	7.2	8	8.8	ns
Duty_G	Duty Cycle for Gigabit	45	50	55	%
Duty_T	Duty Cycle for 10/100T	40	50	60	%
Tr/Tf	Rise/Fall Time (20% to 80%)	-	-	0.75	ns

[1] For 10/100/1000T operation, TXC and RXC will be 2.5 MHz, 25 MHz and 125 MHz respectively.

Table 4 RGMII-ID PHY Mode Timing Specification

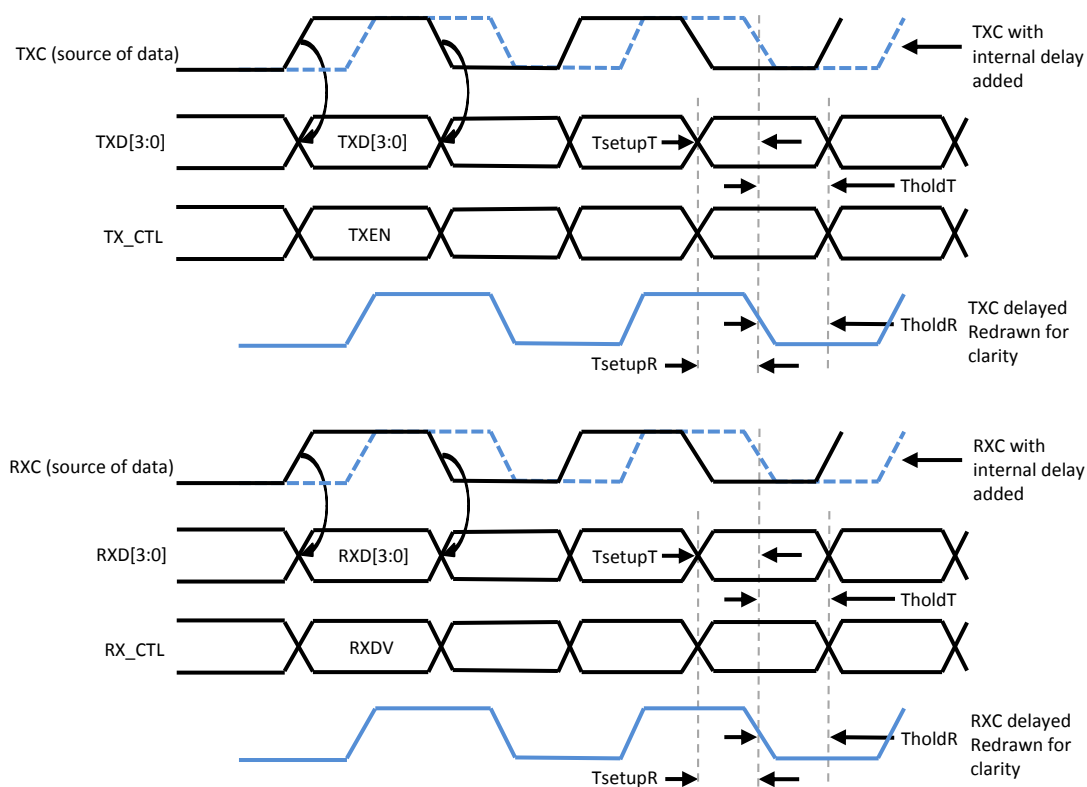

Powerline Modules

500Mbps Module

Symbol	Parameter	Min	Typ	Max	Units
TDLY_MDIO	MDC to MDIO (Output) Delay Time	0	-	20	ns
TSU_MDIO	MDIO (Input) to MDC Setup Time	10	-	-	ns
THD_MDIO	MDIO (Input) to MDC Hold Time	10	-	-	ns
TP_MDC	MDC Period	83.3	-	-	ns
TH_MDC	MDC High	30	-	-	ns
TL_MDC	MDC Low	30	-	-	ns

Table 5 RGMII Timing Specification (MDC/MDIO)

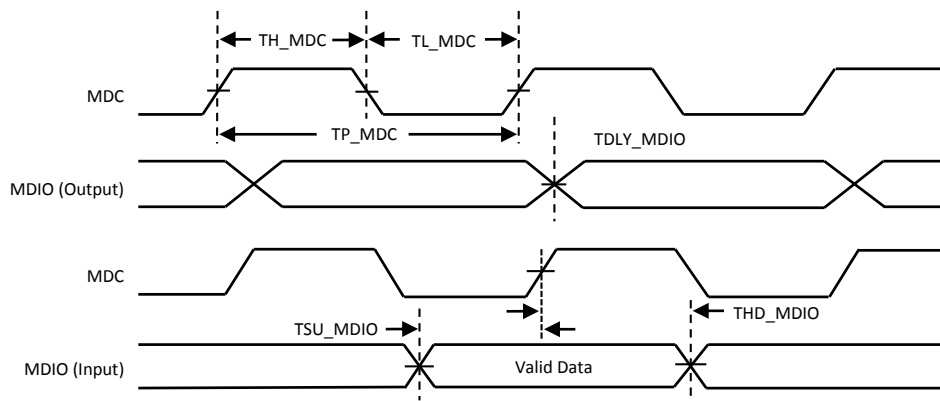

Powerline Modules

500Mbps Module

General Purpose Input/Output (GPIO) Pins Interface

The GPIO Pins have two uses, firstly for configuration and secondly as status outputs and control inputs. The following table shows the provided default Pull Up/Down configuration.

Pin Number	Pin Name	Configuration Strap Function	Internal Pull Up/Down
12	GPIO0	ENET_SEL[0]	Up
13	GPIO1	ENET_SEL[1]	Up
14	GPIO2	ANEN	Up
21	GPIO3	ISODEF	Down
16	GPIO4	SPEED_SEL[0]	Up
17	GPIO5	MD_A3	Up
18	GPIO6	CFG_SEL	Up
19	GPIO7	MD_A4	Down
20	GPIO8	MP_SEL	Up
22	GPIO10	BM_SEL	Up
23	GPIO11	SPEED_SEL[1]	Down

The following table shows the GPIO usage input and lead status feedback.

GPIO	I/O	Default Function After Reset
GPIO1	I	Typically connected to a push-button. This GPIO is used to add a new device to, or remove an old device from, a HomePlug AC logical network.
GPIO2	I	Typically connected to a push-button. The factory default can be restored by applying a low-level digital voltage on GPIO2 for greater than 0.5 seconds and less than 3.0 seconds.
GPIO8	O	To be connected to an LED. The LED gives indications about Powerline link & activity. On: Powerline link detected. Flash: TX or RX Powerline activity. Off: Powerline link not detected.
GPIO3	O	To be connected to an LED. The LED gives indications about Ethernet link & activity. On: Ethernet link detected. Flash: Transmit or receive activity. Off: No link detected.
GPIO11	O	To be connected to an LED. The LED gives indication about power. On: Power ready. Flash: Load firmware ^[1] . (<i>Boot loader mode</i>) Off: Power not ready.

[1] Should the modules flash memory be corrupted/blank, the module ROM based code will blink the POWER LED On and Off at a frequency of one cycle per second.

Powerline Modules

500Mbps Module

PHY Utility Interface

Pin Number	Pin Name	I/O	Description
47	PHY_RST#	O	PHY device Reset (active low). Connect to an external Ethernet PHY. This reset output is a stretched version of the RESET# input.
49	PHY_CLK	O	25MHz Clock Out. This output is a dedicated clock output that can be used to drive the clock input on an external Ethernet PHY. This clock output is only available when the Powerline chipset is configured in MAC mode, and not in PHY mode of operation. Note that if this output is used, it is strongly advised that the corresponding PHY_RST# signal also be connected to the external Ethernet PHY.

Coupling Interface

Pin Number	Pin Name	I/O	Description
6	TXRX+	I/O	100R differential TX/RX+ Powerline data, connects to coupling transformer
7	TXRX-	I/O	100R differential TX/RX- Powerline data, connects to coupling transformer

Special care must be taken during PCB layout of the coupling interface signals.

Route differential pairs close together and away from all other signals. Route each differential pair on the same PCB layer. Keep both traces of each differential pair as identical to each other as possible.

Wide copper is needed here to support current density of up to 70MHz. These high frequencies result in higher resistance due to skin effect. The wide traces also accommodate high transient currents caused by voltage spikes. Trace widths between the module and the coupling transformer must be no less than 0.020" (0.5 mm) and should be no greater than 0.030" (0.75 mm).

Use of the Bel Fuse 0557-7700-36 or 0557-7700-42 Powerline couplers is recommended. Details can be found on the Powerline Couplers datasheet.

Reset, Zero Crossing and Power connections

Pin Number	Pin Name	I/O	Description
1, 3	VDD	I	+3.3V with respect to VSS
5	VNET_IO	I	+2.5V or +3.3V to power MII/RGMII I/O
2, 4, 8, 29, 36, 46, 48, 50	VSS	I	Ground
11	RESET#	I	Resets all IC logic when low. Maintain this signal active for 100ms after the VDD rail is stable.
24	ZC_IN	I	Zero Cross Detector Input. This should be provided from a safety isolated source (opto-isolator). The waveform is to correspond to the polarity of the AC live waveform. For dry wire or DC safety this should be connected to VCC via a pull up (10kΩ). This information synchronizes the channel adaptation of the Powerline chipset to the line cycle periodic noise present on the power line.

Powerline Modules

500Mbps Module

Configuration Options

The Powerline chipset Ethernet Mode and boot options are selected by the initial condition of GPIO pins. If a GPIO pin is not used and its internal strapping resistor sets the booting option correctly, then the pin may be left unconnected. If a GPIO pin is not used but the internal strapping resistor sets the booting option incorrectly, then the pin must be pulled high or low to the correct booting option by an external resistor. All pull-up/pull-down resistors should be 3.3kΩ.

Many GPIO pins are driven by firmware for LED output immediately after boot up so connecting these GPIO directly to ground or VDD is not permitted.

Pin	Pin Name	Strap Function	Internal Pull	Default Function
12	GPIO0	ENET_SEL[0]	Up	MII/RGMII: 10/100 MII (0804-5000□51 ONLY)
13	GPIO1	ENET_SEL[1]	Up	MII/RGMII: 10/100 MII (0804-5000□51 ONLY)
14	GPIO2	ANEN	Up	PHY MODE : Auto negotiate Enabled
21	GPIO3	ISODEF	Down	PHY MODE: Normal operation
16	GPIO4	SPEED_SEL[0]	Up	PHY MODE: 100Mbps
23	GPIO11	SPEED_SEL[1]	Down	PHY MODE: 100Mbps
17	GPIO5	MD_A3	Up	PHY MODE: PHY address 0x08
18	GPIO6	CFG_SEL	Up	BOOT: SDRAM parameters from Flash
19	GPIO7	MD_A4	Down	PHY MODE: PHY address 0x08
20	GPIO8	MP_SEL	Up	HOST: MAC mode
22	GPIO10	BM_SEL	Up	BOOT: Firmware from Flash
49	PHY_CLK	DUPLEX	Up	PHY MODE: Full Duplex

Boot / Run Options

The BM_SEL strap is used to determine the source of the boot code for the embedded ARM processor. Similarly, the CFG_SEL strap is used to determine the source of the DDR memory configuration. The encodings for these two signals is shown in the following table.

BM SEL	CFG SEL	Meaning
0	0	Not supported
0	1	Not supported
1	0	Not supported
1	1	Load DDR configuration and boot code from Flash.

Powerline Modules

500Mbps Module

LED and Push-button Strapping

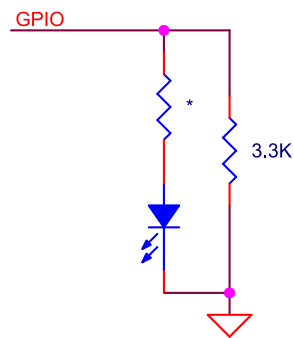

Figure 1 LED Strapping for GPIO Pull-down

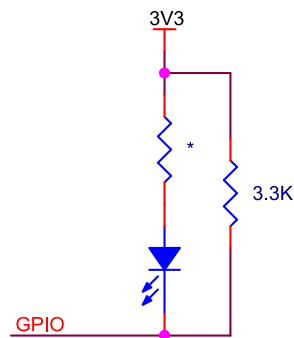

Figure 2 LED Strapping for GPIO Pull-up

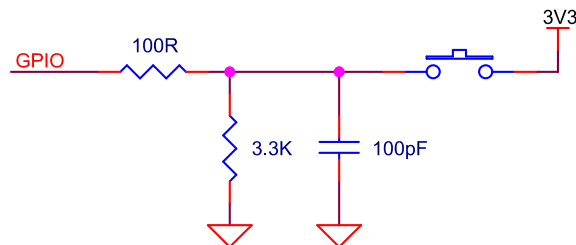

Figure 3 Push-button Strapping for GPIO Pull-down

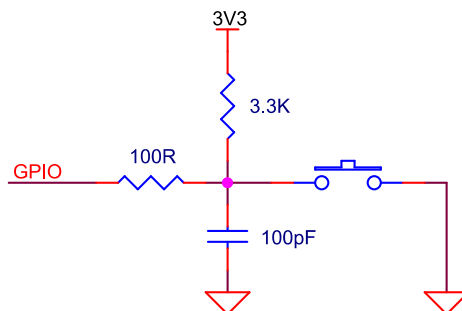

Figure 4 Push-button Strapping for GPIO Pull-up

Powerline Modules

500Mbps Module

General Specifications

Symbol	Parameter	Test Conditions	Min	Max	Units
VDD	Supply voltage ^[1]		3.0	3.6	V
VIL	Low-level input voltage			0.8	V
VIH	High-level input voltage		2.0		V
VOL	Low-level output voltage	IOL = 4 mA, 12 mA ^[2]		0.4	V
VOH	High-level output voltage	IOH = -4 mA, -12 mA ^[3]	2.4		V
IIL	Low-level input current	VI = Gnd	-1		μA
IiH	High-level input current	VI = 3.3 V		1	μA
IOZ	High-impedance output current	Gnd < VI < 3.3 V	-1	+1	μA
Top	Operating temperature range		-40	+85	°C

[1] A typical supply current, assuming a nominal operation of 50% transmit and 50% receive duty cycle, is 770 mA.

[2] IOL=12 mA for all GPIOs. IOL = 4 mA for all other digital interfaces.

[3] IOH = -12 mA for all GPIOs. IOH = -4 mA for all other digital interfaces.

0804-5000-18/24 to 0804-5000□51 Compatibility

The 0804-5000□51 SIP has been designed to be backward compatible with the existing 0804-5000-18/24 within the limits of the chipset utilized. As such there are a few minor limitations and full product testing should be conducted following an upgrade.

- The maximum Ethernet data rate will be 10/100Mbps as the 0804-5000□51 utilizes the slower MII interface. Not all MII PHY's have been tested so careful consideration should be made in regards to track lengths.
- To ensure correct operation any Pull up/downs GPIO straps should be changed from 10kΩ to 3.3kΩ.

Design Notes

Follow below table for unused signal lines:

GPIO[11:0]	PHY_CLK	PHY_RST#	MRX_ERR	COL	CRS	ZC_IN	Action if signal not used
✓	✓	✓					Leave unconnected
			✓	✓	✓		Pull down by 10kΩ resistor
						✓	Pull up by 10kΩ resistor

Special attention must be made to the RGMII interface lines on the 0804-5000□50. The RGMII interface uses 12 High speed data (125 MHz DDR) lines, control and clock signals, care must be taken to ensure signal integrity. The electrical lengths of the traces are divided into two match groups.

Group 1	Group 2
TXC	RXC
TX_CTL	RX_CTL
TD[3:0]	RD[3:0]

Within each match group the maximum trace length should be less than 2 inches (50 mm) and the electrical length must match within 5%. These signals where possible should be routed on internal layers. In MII mode (0805-5000□51) the maximum data rate is 25 MHz, so although signal integrity is important it is not as critical as that of RGMII.

Powerline Modules

500Mbps Module

Mechanical

Horizontal Mount - Industrial Temperature with Heatsink

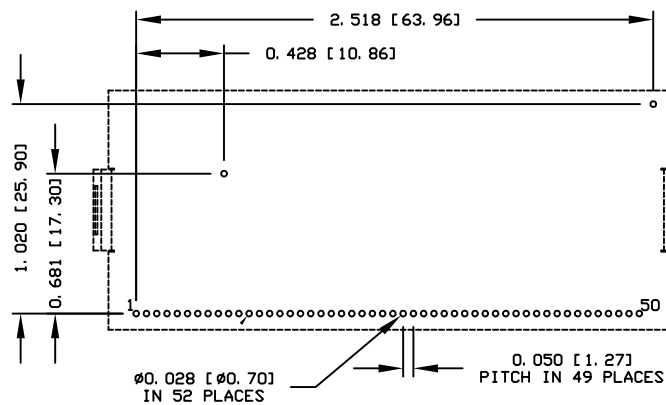
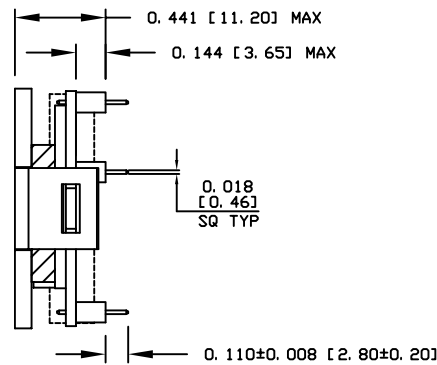
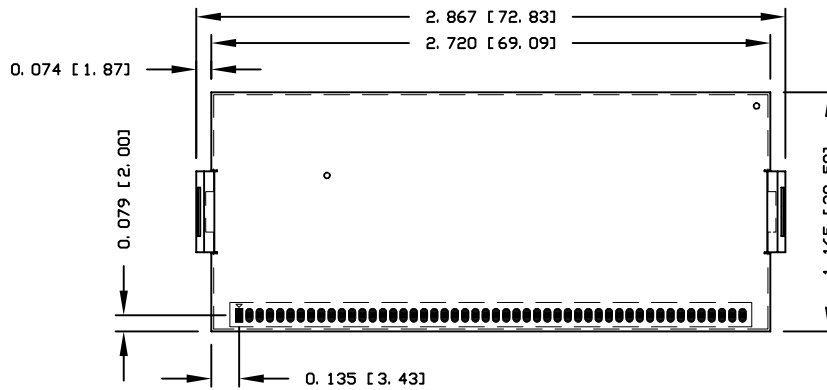

RECOMMENDED PCB LAYOUT