



MELCHER™
The Power Partners.

LBM Series

3-phase PSU / Battery charger



The Power Supply Unit (PSU) consists of two independent power modules working in parallel, to ensure a reliable redundancy. It has a 3-phase input for 400 / 480 VAC (line to line) and a galvanically isolated output suitable for 110 V battery charging and supplying DC loads.

AC-DC stage to convert the 3-phase input voltage to a bus voltage with battery charging capability. Emphasis is given on high reliability and long life.

The PSU includes DSP, which enables monitoring of electrical parameters (including input voltage of all 3 phases) and controlling the PSU from the system controller. Internal CAN bus is used for command, monitoring and diagnostic information that is supplied to the shelf DSP controller and to the external supervising system. External communication is provided by either CAN or Ethernet communication.

The LBM series is a highly versatile battery charger which adapts easily to the different requirements of rolling stock on-board power grids and vehicle control systems.

The firmware is programmed according customer required parameters, depending on type of battery, charging characteristic, specific monitoring, controlling and communication requirements.



¹ Pending

FEATURES

- Full digital control design
- Output power up to 15 kW
- 400 / 480 Vrms 3-phase 50/60 Hz input voltage range (no neutral)
- Power factor > 0.94
- High power density 12.2 W/in³
- Typical efficiency 93%
- Parallel operation of max. 4 units (project dependent)
- Nominal output voltage for 110 V battery (adjustable 80 - 140 VDC)
- Ambient operating temperature -40 to 70°C
- CAN bus / Ethernet Interface
- Compliant to Railway standards EN 50155, EN 50121-3-2, EN 50533, EN 45545 (HL3), NFPA 130, EN 50657, EN 50128, EN 50129, IEC 62443-4-1 / 4-2
- Safety approved to the latest edition of IEC 62368-1 and CSA/UL 62368-1 (Pending Approval)
- 5 year warranty



belfuse.com/power-solutions



1. MODEL SELECTION

MODEL	POWER	BATTERY VOLTAGE	COMMUNICATION
LBM10000-1110Sxxx *	10000	110 V	CAN or Ethernet
LBM12000-1110Sxxx *	12000	110 V	CAN or Ethernet
LBM15000-1110Sxxx *	15000	110 V	CAN or Ethernet

* For details regarding finished good part number, please, contact the factory

2. INPUT SPECIFICATIONS

PARAMETER	DESCRIPTION / CONDITION	MIN	NOM	MAX	UNIT
Input Voltage	Line to line without neutral:	350	400 - 480	528	Vrms
	Line to ground:	202	230 - 277	305	
Input Frequency		42	50 - 60	63	Hz
Input Current	LBM10000 at 350 Vrms from each phase			18	A
	LBM12000 at 350 Vrms from each phase			21	
	LBM15000 at 350 Vrms from each phase			26	
Inrush Current	>1 minute cooling (turned-off) period			100	Apk
Power Factor	At 400 Vrms, nominal power, 25 °C	0.9			
I-THD	At 400 Vrms, nominal power, 25 °C		33	37	%
Fuse	Fast acting, 3 fuses per each power module (2 PSUs per shelf)			20	A

3. OUTPUT SPECIFICATIONS

PARAMETER	DESCRIPTION / CONDITION	MIN	NOM	MAX	UNIT
Output Voltage	Depending on operating condition and specific battery charging characteristics	80		140	VDC
Output Power Rating	LBM10000			10000	W
	LBM12000			12000	
	LBM15000			15000	
Output Current	LBM10000			91	A
	LBM12000			110	
	LBM15000			137	
Efficiency	At load above 40%		93		%
Voltage Setting Accuracy		-6		+2	%
Line Regulation		-1		+1	%
Load Regulation		-6		+2	%
Transient Response	At load variation 50-100% lo_nom and back Recovery time:	-5		+5	%
				20	ms
Output Voltage Ripple	BW 20 MHz			4.5	% Vout_ nom
Charging Current Accuracy	Measured 6 s after the end of Battery test	-2		+2	A

4. PROTECTION SPECIFICATIONS

PARAMETER	DESCRIPTION / CONDITION
Protection	Over temperature protection (see Chapter 8), Input under / over voltage protection (340 - 350 VAC / 528 - 540 VAC), Output under / over voltage protection (60 VDC / 150 VDC), Battery OTP at TB1, TB2 over 50°C (Icharge = 0) Over current protection Short circuit protection



5. OPERATION MODES

PARAMETER	DESCRIPTION / CONDITION	NOTES
Vbat = < 80 V	Battery Low: warning Battery_Low, consumers should be in OFF state, battery charging with reduced I _{ch} , all up to 80V	Warning by comm. bus (Ethernet or CAN) or by relay
Vbat = 80 – 140 V	Battery Normal: charging with I _{ch_nom} according to battery characteristic	Up to V _{ch} = V @ current T _{batt}
Charging Characteristics	V _{ch} = f (TB1, TB2 – batt temp): typ. -3 mV / K /cell (curve adjustable according to specific battery type), Boost and Floating modes optional	Default I _{ch_nom} = 20 A, customizable
Failure Effect	In the case of external communication failure or battery temperature (both) sensors failure, the charging / supplying continues in Safe mode – reduced V _{ch} only In the case one power module fails, the charging / supplying continues with reduced power (If the overall power consumption will be P _{nom} /2, the redundancy will be possible - no power reduction)	V _{ch} @ Safe mode ~ V @ T _{max} (battery curve)
Battery Test*	Checked battery connection and battery voltage, default once after turn-on (repetition on request, e.g. once per 12 hours)	Performed when AC available

* During battery test, the voltage can drop down to 80 V, if the battery is not connected. In this case the charger will go to the Safe mode. (Safe mode default V_{ch} = 105 V, customizable).

6. LED SIGNALING

6.1 CONTROL UNIT

LED NAME	SYMBOL	COLOR	STATUS	OPERATING CONDITIONS
STATUS		Green	ON Blinking slowly Blinking fast	Input line ON, Battery ON Input line OFF, Battery ON Input line ON, Battery OFF
BATTERY CURRENT		Green / Chartreuse / Yellow	ON Blinking slowly	G-Charging / Ch-Current <±2 A / Y-Discharging Output disabled
FAIL / SAFE MODE		Yellow	ON Blinking slowly	Fail (e.g. Overload) Safe mode (reduced voltage)

6.2 ETHERNET

LED NAME	SYMBOL	COLOR	STATUS	OPERATING CONDITIONS
Data Activity		Green	Blinking OFF	Data is sensed thru the port No data
Operating		Green	ON OFF	Communication line connected Communication line broken

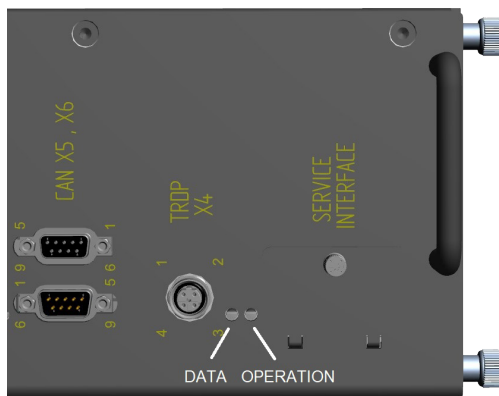

Figure 1. Ethernet connector X4, LED positions



7. SAFETY, REGULATORY AND EMI SPECIFICATIONS

PARAMETER	DESCRIPTION / CONDITION	CRITERION
Safety	CE Declaration of Conformity, CSA Recognition, AREMA, UL/CSA 62368-1	
Emission	Radiated & Conducted Emissions (EN 50121-3-2, EMW-06, AREMA 11.5.2, FCC part 15)	0.15 MHz - 3 GHz AREMA Conducted for output - an external filter required
Immunity	Electrostatic Discharge (IEC/EN 61000-4-2)	Level 4: ±8 kV contact ±15 kV air Criterion B
	Radiated Electromagnetic Field (IEC/EN 61000-4-3)	10 V/m 10 kHz – 2 GHz Criterion A
	Electrical Fast Transient (EFT)/Burst (IEC 61000-4-4)	Level 3: ±4 kV Criterion A
	Surge Immunity (IEC/EN 61000-4-5)	Level 3: ±1 kV DM ±2 kV CM Criterion A
	RF Conducted Immunity (IEC/EN 61000-4-6)	Level 3: 10 V, 100 kHz – 80 MHz Criterion A
Life Assessment	>5 years life at ambient temperature of +55°C, 27 years at 25°C, half load Fan – externally accessible for a potential replacement, no need to open the unit cover (see Installation Instructions)	
Other Standards	EN 50155: 2021	Railway applications – Electronic equipment
	EN 45545-2+A1: 2016, HL3	Railway applications – Fire protection on railway vehicles
	NFPA 130: 2017	Fixed guideway transit and passenger rail systems
	EN 50124-1: 2017	Railway applications – Clearances & creepage distances for electronic equipment
	EN 50657: 2017	Electronic railway equipment – SW Functional safety, SIL
	ISO 9001: 2015	Quality management system
	EN 50128: 2012+A2, 2021	Railway applications - Communication, signalling and processing systems
	EN 50129: 2018	Railway applications - Communication, signalling and processing systems
	IEC 62443-4-1 / 4-2: 2018 / 2019	Security for industrial automation and control systems
	ISO 14001: 2015	Environmental management system
IRIS / ISO-TS 22163: 2017	Railway applications - Quality management system	

8. ENVIRONMENTAL SPECIFICATIONS

PARAMETER	DESCRIPTION / CONDITION	MIN	NOM	MAX	UNIT
Operating Temperature	OT4, @ full power	-40		+55	°C
	Linear power derating to 75% of Po_nom, +85°C @ 10 min	+55		+70	
Humidity	Operating range RH According to EN 50155, EN 60068-2-30, test Db variant 2, AREMA 11.5.1	0		95	%
Storage Temperature	0 - 95% RH	-55		+85	°C
Vibration	IEC 61373	Clause 9, Class B (long life test) Clause 8, Class B (random test)		Criterion A	
	AREMA 11.5.1				
Shock	IEC 61373 Clause 10, Class B (30/30/50 m/s²) AREMA 11.5.1	Criterion A			
Altitude Level	Class AX	no derating derating 80% of Pnom		2500 5000	MASL
Acoustic Noise Emission	ISO 9296, ISO 7779, ISO 9295	Lwa ≤ 65 dB-A @ full load, 25°C			



9. CONNECTORS

PARAMETER	DESCRIPTION / CONDITION	TYPE / MATING PART
Input Connector X1	4-pin terminal block	DFK-PC16/4-STF-10,16-1703470 / PC16/4-STF-10,16-1967472 (Phoenix Contact); Wires, max. 16 mm ² , torque 1.7-1.8 Nm
Output Connector X2	6-pin terminal block	PC35HC/6-GF-15,00-1762783 / PC35HC/6-STF-15,00-1762631 (Phoenix Contact); Wires, max. 35 mm ² , torque ≤25 mm ² = 2.5 Nm; >25 mm ² = 4.5 Nm
Signal Connector X3	15-pin Combicon	MSTB2.5/15-GF-1776825 / MSTB2.5/15-STF-1786967 or FKCN2.5/15-STF-1733084 (Phoenix Contact) Wires, max. 2.5 mm ² , torque max. 0.6 Nm
Ethernet Comm. Connector X4	4-pin M12 D-Coding Female	4-pin M12 D-coded-1534630 / 4-pin M12 D-coded-1521258 (Phoenix C) Wires, max. 0.75 mm ² , torque max. 0.2 Nm
CAN Comm. Connector X5	9-pin D-SUB Male	9-pin D-SUB male / 9-pin D-SUB female (Amphenol)
CAN Comm. Connector X6	9-pin D-SUB Female	9-pin D-SUB female / 9-pin D-SUB male (Amphenol)
Signal Connector X7	6-pin Base Strip	MC1,5/6-GF-3,5-1843839 / MC1,5/6-STF-3,5-1847097 (Phoenix Contact) Wires, max. 1.5 mm ² , torque max. 0.25 Nm

NOTE: The mating connectors are not part of the delivery.

9.1 INPUT AC CONNECTOR X1 – PINOUT

SIGNAL NAME	PIN#	TYPE	RECOMMENDED WIRES	ABSOLUTE V MAX ABSOLUTE I MAX
Earth	⊕	Earth / Chassis	6 mm ²	528 Vrms (line to line) 26/18 Arms (per line)
AC Line 1	L1	Input Power AC, Fused	6 mm ²	
AC Line 2	L2	Input Power AC, Fused	6 mm ²	
AC Line 3	L3	Input Power AC, Fused	6 mm ²	

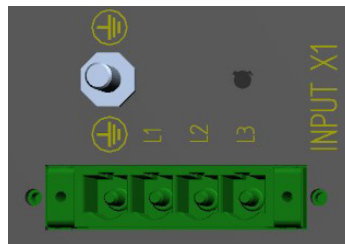

Figure 2. Input Connector X1

9.2 OUTPUT & BATTERY CONNECTOR X2 – PINOUT

SIGNAL NAME	PIN#	TYPE	SIGNAL REFERENCE	RECOMMENDED WIRES	V MAX I MAX
Consumer +	1, 2	Output Power DC	Common -	2x 16 mm ²	140 VDC 137/91 A
BAT +	3, 4	Output Power DC	Common -	2x 16 mm ²	
Common -	5, 6	Output Power DC_return		2x 16 mm ²	

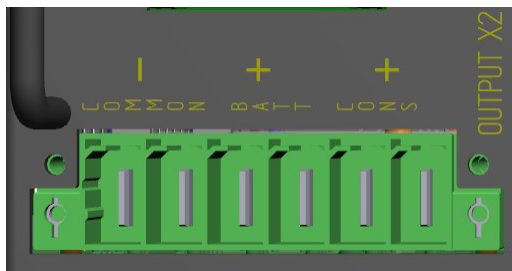

Figure 3. Output & Battery Connector X2



9.3 SIGNAL CONNECTOR X3 – PINOUT

SIGNAL NAME	PIN#	TYPE	SIGNAL REFERENCE	LOW / HIGH LEVEL	V MAX I MAX
VBsense1	1	Battery Voltage Sense 1 ***	GRD	0 - 140 V	140 V
VBsense2	2	Battery Voltage Sense 2 ***	GRD	0 - 105 V	140 V
VBsense3	3	Battery Voltage Sense 3 ***	GRD	0 - 70 V	140 V
VBsense4	4	Battery Voltage Sense 4 ***	GRD	0 - 35 V	140 V
GRD	5	Return	Isolated from Common -		
N.C.	6				
Vaux_in	7	Controller supplying, connect ext. to pin 8	Common -		140 V
+110Vdc	8	This pin is connected internally to Bat+	Common -		140 V
Common -	9	Return			
ADR0	10	Unit Address 0 *, floating = 0 **	Common -	< 12 V / > 80 V	140 V
ADR1	11	Unit Address 1 *, floating = 0 **	Common -	< 12 V / > 80 V	140 V
INH	12	Inhibit *, floating = 0 **	Common -	< 12 V / > 80 V	140 V
P_LIM	13	Power Limitation *, floating = 0 **	Common -	< 12 V / > 80 V	140 V
FA	14	Floating relay contact (normally open) Open when in fault condition *			0.4 A @ 140 VDC
FB	15				

* Defined by the Configuration file (a part of the firmware)

** For log. 1 connect by a jumper/relay the relevant pin to pin 1, VBsense1 (where the BAT+ is connected)

*** For a description of the connection to battery, see Figure 8

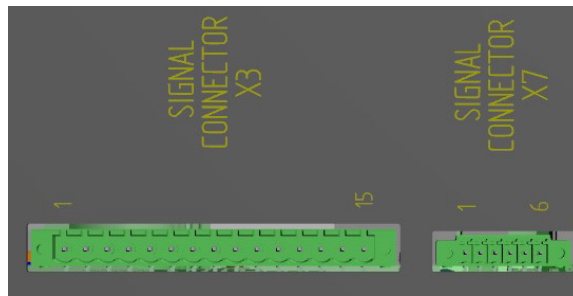

Figure 4. Signal Connectors X3 & X7

9.4 ETHERNET CONNECTOR X4 – PINOUT

SIGNAL NAME	PIN#	TYPE	SIGNAL REFERENCE	NOTES	V MAX I MAX
TxData+	1	Communication Data		10/100 Mbit	
RxData+	2	Communication Data		10/100 Mbit	
TxData-	3	Communication Data		10/100 Mbit	
RxData-	4	Communication Data		10/100 Mbit	

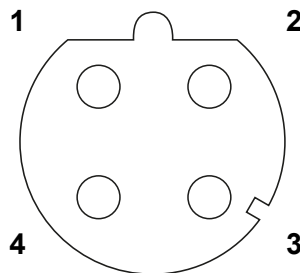

Figure 5. Ethernet Connector X4 Pinout (on the unit)

9.5 CAN-BUS CONNECTOR X5, X6 – PINOUT

SIGNAL NAME	PIN#	TYPE	SIGNAL REFERENCE	NOTES	V MAX I MAX
CAN +	7	Communication Data	CAN-	250 kbit *	
CAN -	2	Communication Data	CAN+	250 kbit *	
GRC	3	Power Supply_return		Do not use - only for servicing	
+5V	9	Power Supply	GRC	Do not use - only for servicing	5.5 V / 100 mA

* Defined by the Configuration file

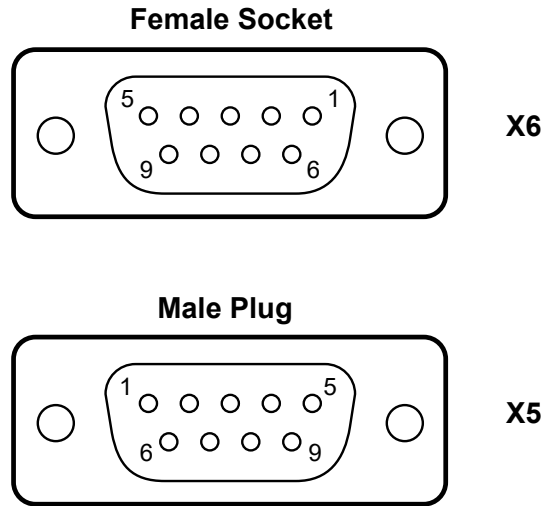

Figure 6. CAN Bus Connector X5, X6 Pinout (on the unit)

9.6 SIGNAL CONNECTOR X7 – PINOUT

SIGNAL NAME	PIN#	TYPE	SIGNAL REFERENCE	NOTES	V MAX I MAX
TB1H	1	Temperature sensor 1 High	TB1L	For 103AT-11, Semitec *	3.3 V
TB1L	2	Temperature sensor 1 Low			3.3 V
TB2H	3	Temperature sensor 2 High	TB2L	For 103AT-11, Semitec *	3.3 V
TB2L	4	Temperature sensor 2 Low			3.3 V
N.C.	5				
Common -	6	Can be used to connect the cable shielding		Do not connect the cable shielding to earth (chassis)	

* Or similar NTC 10k @ 25°C, function R/T can be customized (the characteristic is configurable in Config File)

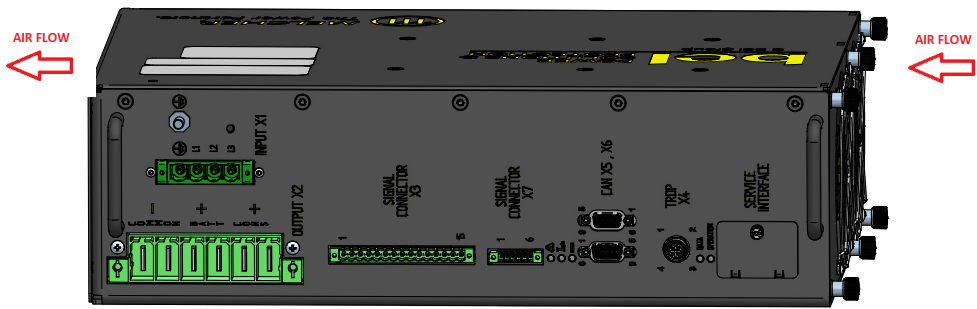

Figure 7. Connector positions & air flow direction

NOTE: Keep min. 10 cm free space around all airflow openings (min. 15 cm from the air inlet side)!
Ensure sufficient external ventilation (do not use recirculated-air mode).

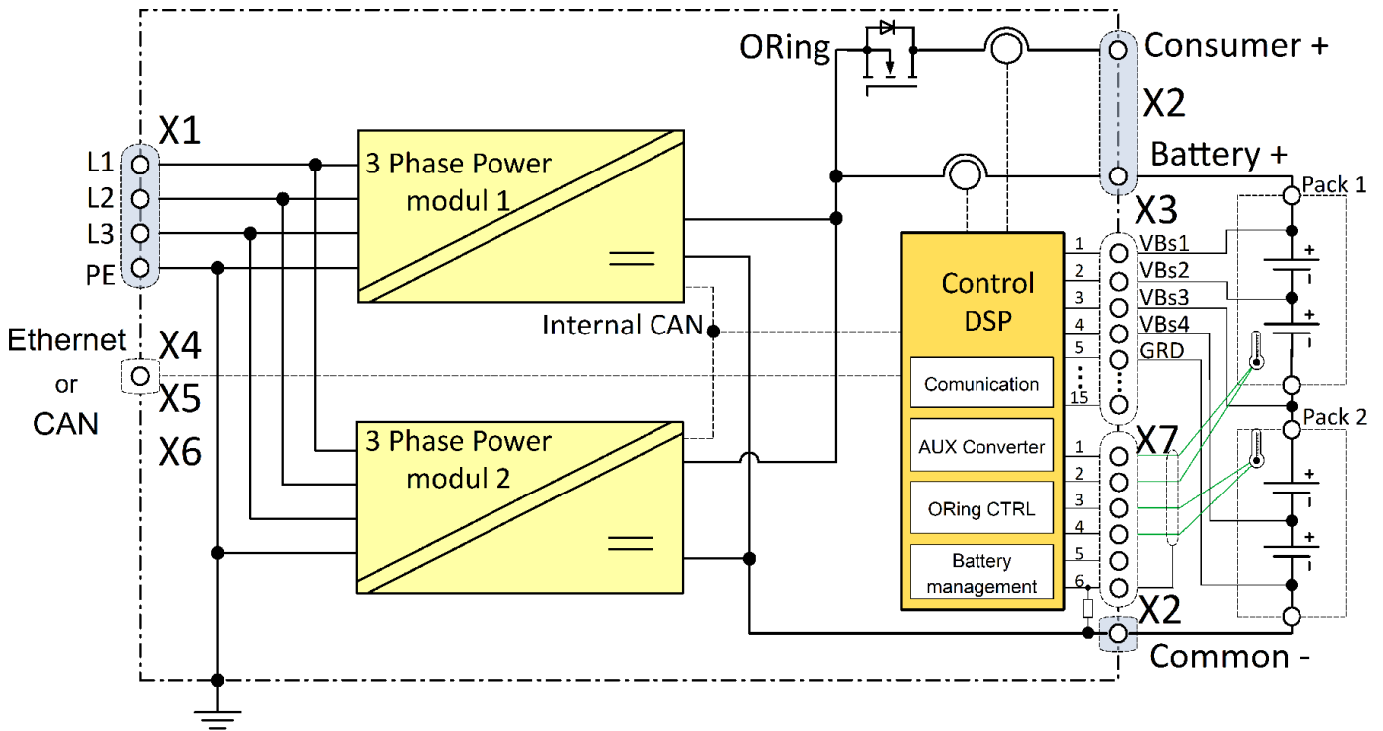

Figure 8. Connectors meaning and block diagram (thermal sensors are a part of the battery pack)

9.7 OPERATION

The LBM unit automatic start-up and selected working mode is defined in the Configuration file. LBM can work in 3 modes:

- Charge mode
 - voltage is set according to battery temperature defined in Configuration file
 - charging current is limited according to Configuration file
 - consumer current limited only by max. power, then consumers further supplied by battery
- Safe mode
 - voltage is set to safe mode voltage (default 105V)
 - charging current is limited according to Configuration file
 - consumer current limited as above
- Source mode
 - voltage is set according to command received from TCMS
 - charging current set to 0 (no battery connected)
 - consumer current limited according to command received from TCMS

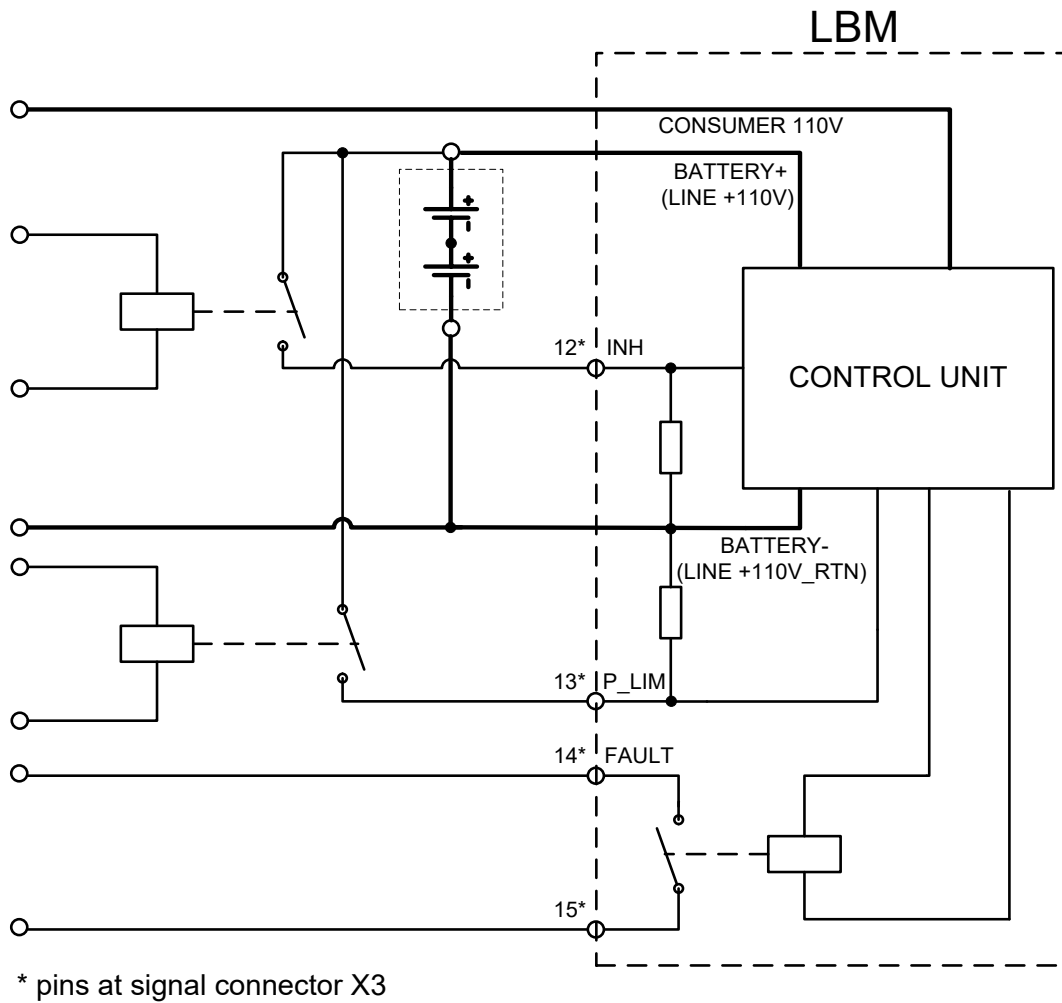

Figure 9. Static signals, connection example

10. MECHANICAL SPECIFICATIONS

PARAMETER	DESCRIPTION / CONDITION		UNIT
Rack Dimensions (W x D x H)	Without mounting holders	440 x 340 x 131 17.3 x 13.4 x 5.2	mm in
Weight	Including holders and related screws	18.5	kg
Cooling	Forced airflow - externally accessible serviceable fans (maximum power dissipation ~ 1100 W)		
Insulation	Input to output	2.0	kVrms
	Input to chassis	2.0	
	Output to chassis	2.0	
	Output to battery sense signals	0.25	
	Communication signals (CAN, ETH) to chassis (D-Sub limit)	0.5	
	Communication signals to input, output	2.0	
Recommended mounting position	Vertical (connectors on top) or horizontal (in rack)		
Enclosure	IP20		

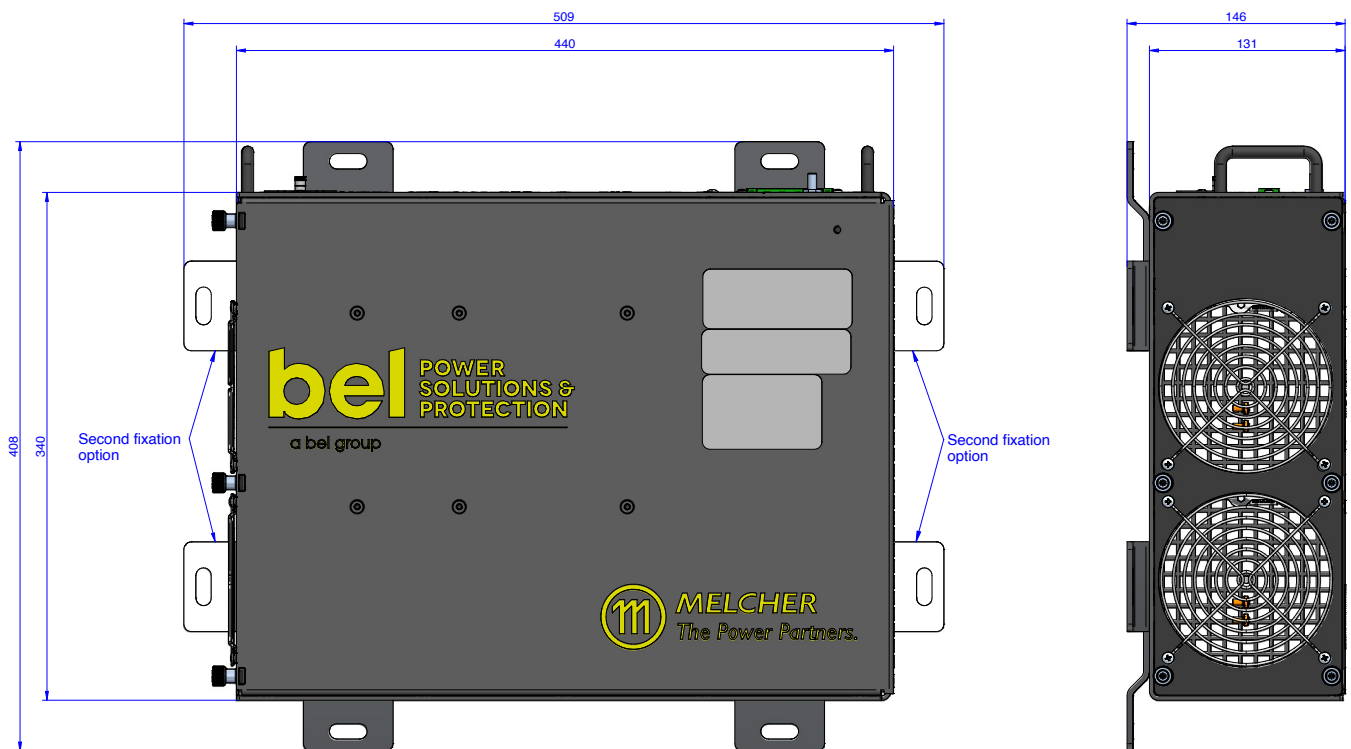

Figure 10. Mechanical dimensions

NOTE: This is a generic datasheet valid for LBM basic model. For a specific model, please, see the documents Parameters Configuration File and Special datasheet, which describes all the deviations from the basic model (the battery specification, the charging current and curve, the communication protocol and the specific settings set in the Configuration file, which is a part of the FW).

For more information on these products consult: tech.support@psbel.com

NUCLEAR AND MEDICAL APPLICATIONS - Products are not designed or intended for use as critical components in life support systems, equipment used in hazardous environments, or nuclear control systems.

TECHNICAL REVISIONS - The appearance of products, including safety agency certifications pictured on labels, may change depending on the date manufactured. Specifications are subject to change without notice.