

**SERIES:** VSBU-150 | **DESCRIPTION:** AC-DC POWER SUPPLY

**FEATURES**

- up to 150 W combined power
- open frame
- active power factor correction
- class I insulation
- output voltage available from 9 to 48 V dc
- over voltage protection, input surge current protection, over load protection
- 88% efficiency



MODEL	output voltage	output current	output power	ripple and noise	efficiency
	(Vdc)	max (A)	max (W)	max (mVp-p)	typ (%)
VSBU-150-9	9	16	144	90	88
VSBU-150-12*	12	12.5	150	120	88
VSBU-150-15	15	10	150	150	88
VSBU-150-18	18	8.33	150	180	88
VSBU-150-24	24	6.25	150	240	88
VSBU-150-30	30	5	150	300	88
VSBU-150-36	36	4.17	150	360	88
VSBU-150-48	48	3.13	150	480	88

Note: 1. \* Discontinued model with power fail detect (-P)

**PART NUMBER KEY**

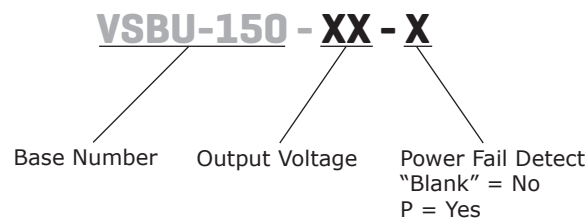

**INPUT**

parameter	conditions/description	min	typ	max	units
voltage		90		264	Vac
frequency		47		63	Hz
current	at 115 Vac, full load			2.0	A
	at 230 Vac, full load			0.8	A
inrush current	at 115 Vac, 25°C, full load, cold start			40	A
	at 230 Vac, 25°C, full load, cold start			100	A
power factor correction	at 240 Vac, full load	0.95		1.0	

**OUTPUT**

parameter	conditions/description	min	typ	max	units
line regulation	full load		0.5	1	%
load regulation	at 230 Vac			5	%
temperature coefficient	all output	-0.04		0.04	%/°C
transient response	full load to half load at 100 Vac			4	ms
start-up	full load at 100 Vac			3	s
hold-up	full load at 110 Vac	16			ms

**PROTECTIONS**

parameter	conditions/description	min	typ	max	units
over voltage protection		112		132	%
over current protection		110		150	%

**SAFETY & COMPLIANCE**

parameter	conditions/description	min	typ	max	units
isolation voltage	primary to secondary	4,242			Vdc
	primary to earth ground	2,837			Vdc
isolation resistance	test voltage of 500 Vdc	50			MΩ
safety approvals	UL/cUL, CISPR-22 class B, FCC part 15 class B, CB				
EMI/EMC	CISPR 22 class B, FCC part-15 class B				
leakage current	full load at 240 Vac			0.75	mA
MTBF	MIL-HDBK-217F, 25°C ambient	100,000			hrs
RoHS	2011/65/EU				

**ENVIRONMENTAL**

parameter	conditions/description	min	typ	max	units
operating temperature	see derating curve	0		70	°C
storage temperature		-40		85	°C
operating humidity	non-condensing	5		95	%
storage humidity		5		95	%

## DERATING CURVES

output power vs. ambient temperature

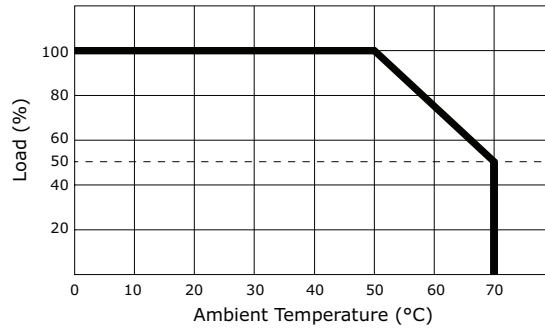

## MECHANICAL DRAWING

units: mm[inches]  
tolerance: ±0.5mm

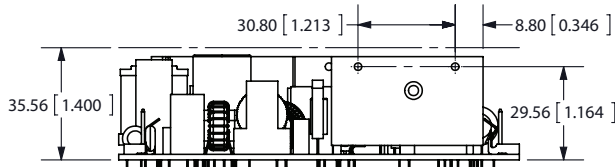
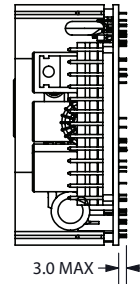
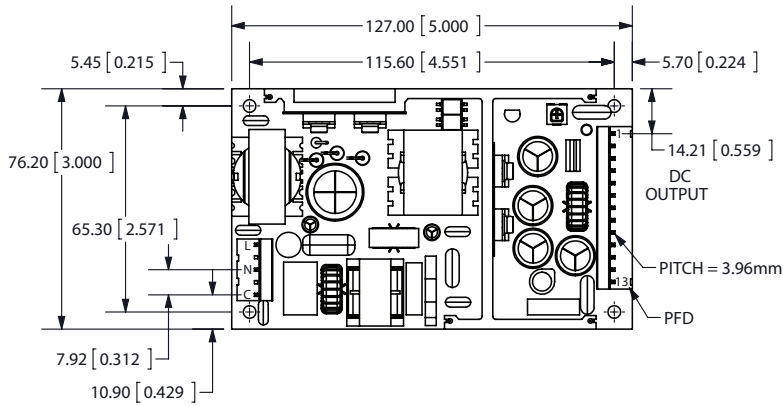
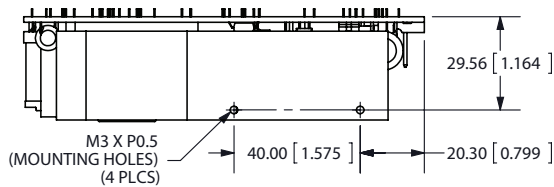

CN1	
1	ac line
2	ac neutral
3	ground

note:

- Input connector mates with Molex housing 09-52-4054 and Molex 2478 series crimp terminal.
- Output connector mates with Molex housing 09-52-4134 and Molex 2478 series crimp terminal.

CN2	
1	V1
2	V1
3	V1
4	V1
5	V1
6	V1
7	com
8	com
9	com
10	com
11	com
12	com
13	n/c

\*pin 13 for optional power fail detect

## REVISION HISTORY

rev.	description	date
1.0	initial release	11/19/2010
1.01	new template applied	08/12/2011
1.02	V-Infinity branding removed	08/16/2012
1.03	updated drawing pinouts	01/15/2013
1.04	updated derating curve	02/12/2013
1.05	updated efficiencies	07/01/2013
1.06	updated recommended mating connectors, updated spec	05/22/2014
1.07	company logo updated	11/02/2020
1.08	updated safety marks and safety approvals	04/27/2021
1.09	discontinued model VSBU-150-12-P	01/04/2026

The revision history provided is for informational purposes only and is believed to be accurate.



# CUI INC

a bel group

15575 SW Sequoia Pkwy #100  
Portland, OR 97224  
800.275.4899

Fax 503.612.2383  
Belfuse.com  
powersupport@belf.com

CUI offers a two (2) year limited warranty. Complete warranty information is listed on our website.

CUI reserves the right to make changes to the product at any time without notice. Information provided by CUI is believed to be accurate and reliable. However, no responsibility is assumed by CUI for its use, nor for any infringements of patents or other rights of third parties which may result from its use.

CUI products are not authorized or warranted for use as critical components in equipment that requires an extremely high level of reliability. A critical component is any component of a life support device or system whose failure to perform can be reasonably expected to cause the failure of the life support device or system, or to affect its safety or effectiveness.