

**SERIES:** SMI6B | **DESCRIPTION:** AC-DC POWER SUPPLY

**FEATURES**

- DoE Level VI, CoC Tier 2 efficiency
- up to 6 W power
- compact design
- interchangeable AC blades
- universal input (90~264 Vac)
- single regulated output from 5~15 Vdc
- over voltage and short circuit protections
- UL/cUL, GS, RCM, CCC, PSE safety approvals
- UL/EN/IEC 62368-1 certified
- custom designs available



| MODEL    | input voltage | input frequency | output voltage | output current | output power | ripple and noise <sup>1</sup> | efficiency level <sup>2</sup> |         | no load power consumption |
|----------|---------------|-----------------|----------------|----------------|--------------|-------------------------------|-------------------------------|---------|---------------------------|
|          | range (Vac)   | range (Hz)      | nom (Vdc)      | max (A)        | max (W)      | max (mVp-p)                   | average <sup>3</sup> (%)      | 10% (%) | typ (W)                   |
| SMI6B-5  | 90 ~ 264      | 47 ~ 63         | 5              | 1.2            | 6.0          | 300                           | 80.5                          | 74.6    | 0.06                      |
| SMI6B-6  | 90 ~ 264      | 47 ~ 63         | 6              | 1.0            | 6.0          | 300                           | 81.3                          | 74.5    | 0.06                      |
| SMI6B-9  | 90 ~ 264      | 47 ~ 63         | 9              | 0.66           | 5.94         | 300                           | 79.6                          | 71.4    | 0.06                      |
| SMI6B-12 | 90 ~ 264      | 47 ~ 63         | 12             | 0.5            | 6.0          | 300                           | 80.9                          | 70.6    | 0.07                      |
| SMI6B-15 | 90 ~ 264      | 47 ~ 63         | 15             | 0.4            | 6.0          | 300                           | 80.9                          | 71.0    | 0.06                      |

Notes: 1. At full load, 100-240 Vac input, 20 MHz bandwidth oscilloscope, output terminated with 0.1  $\mu$ F and 10  $\mu$ F capacitors.  
 2. CoC Tier 2 compliant  
 3. Average efficiency is measured at 25%, 50%, 75%, and 100% load.

**PART NUMBER KEY**

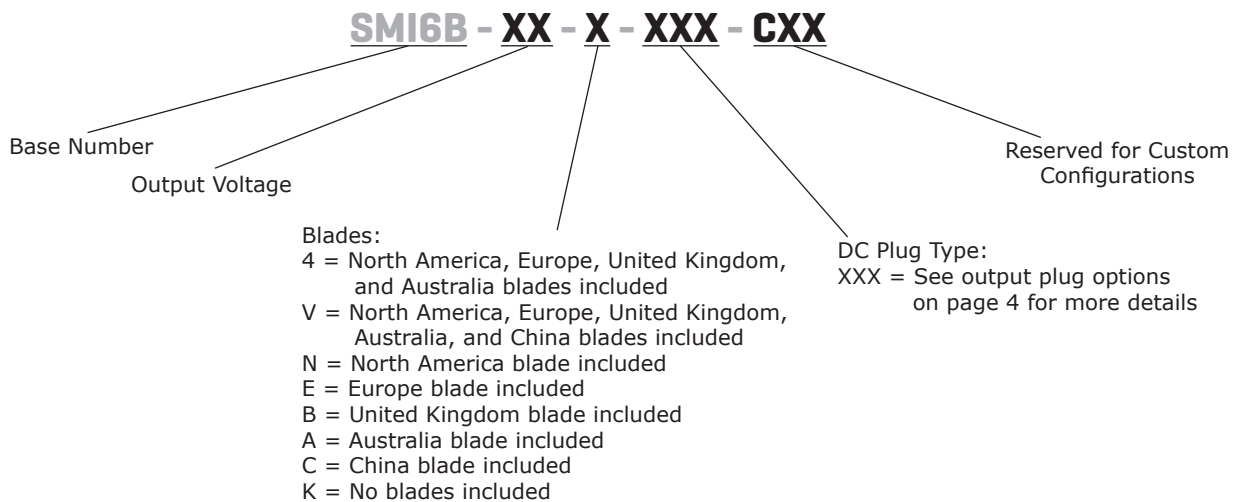

**INPUT**

| parameter                 | conditions/description            | min | typ     | max   | units |
|---------------------------|-----------------------------------|-----|---------|-------|-------|
| voltage                   |                                   | 90  | 100~240 | 264   | Vac   |
| frequency                 |                                   | 47  | 50~60   | 63    | Hz    |
| current                   |                                   |     |         | 0.2   | A     |
| leakage current           | at nominal AC input and frequency |     |         | 0.25  | mA    |
| no load power consumption | at 115/ 230 Vac, 60/50 Hz         |     |         | 0.075 | W     |

**OUTPUT**

| parameter       | conditions/description | min | typ | max | units |
|-----------------|------------------------|-----|-----|-----|-------|
| line regulation |                        |     | ±5  |     | %     |
| load regulation |                        |     | ±5  |     | %     |
| start-up time   | at 115 Vac input       |     |     | 3   | s     |
| rise time       | at 90~264 Vac input    |     |     | 100 | ms    |
| hold-up time    | at nominal input       | 5   |     |     | ms    |

**PROTECTIONS**

| parameter                | conditions/description          | min | typ | max | units |
|--------------------------|---------------------------------|-----|-----|-----|-------|
| over current protection  | output shut down, auto recovery |     |     |     |       |
|                          | 5 Vdc output models             |     |     | 1.8 | A     |
|                          | 6 Vdc output models             |     |     | 1.6 | A     |
|                          | 9, 12 Vdc output models         |     |     | 1.0 | A     |
|                          | 15 Vdc output models            |     |     | 0.8 | A     |
| short circuit protection | output shut down, auto recovery |     |     |     |       |

**SAFETY & COMPLIANCE**

| parameter         | conditions/description  | min    | typ            | max | units      |
|-------------------|---|--------|----------------|-----|------------|
| isolation voltage | input to output at 10 mA for 1 minute                                 |        | 3,000<br>4,242 |     | Vac<br>Vdc |
| safety approvals  | certified to 62368-1: UL, IEC, EN<br>UL/cUL, GS, RCM, CCC, PSE, UKCA  |        |                |     |            |
| EMI/EMC           | FCC Part 15B Class B, CE  |        |                |     |            |
| MTBF              | as per Telcordia SR-332, Issue 2 at 115/230 Vac,<br>full load, 0~40°C | 50,000 |                |     | hours      |
| RoHS              | yes   |        |                |     |            |

**ENVIRONMENTAL**

| parameter             | conditions/description | min | typ | max | units |
|-----------------------|------------------------|-----|-----|-----|-------|
| operating temperature |                        | 0   |     | 40  | °C    |
| storage temperature   |                        | -20 |     | 60  | °C    |
| operating humidity    | non-condensing         | 20  |     | 85  | %     |
| storage humidity      | non-condensing         | 5   |     | 95  | %     |

## MECHANICAL

| parameter          | conditions/description  | min | typ      | max | units  |
|--------------------|---|-----|----------|-----|--------|
| dimensions         | 47 x 34.5 x 26.5  |     |          |     | mm     |
| inlet plug         | interchangeable blades (North America, Europe, UK, Australia, China)                                      |     |          |     |        |
| ac blade clip type | hidden clip   |     |          |     |        |
| weight             | 5 Vdc output models (without interchangeable blades)<br>all other models (without interchangeable blades) |     | 54<br>50 |     | g<br>g |

## MECHANICAL DRAWING

units: mm  
tolerance: ±1 mm

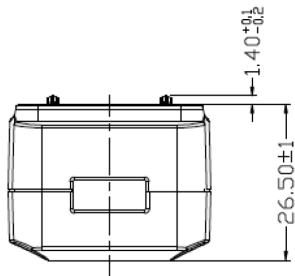
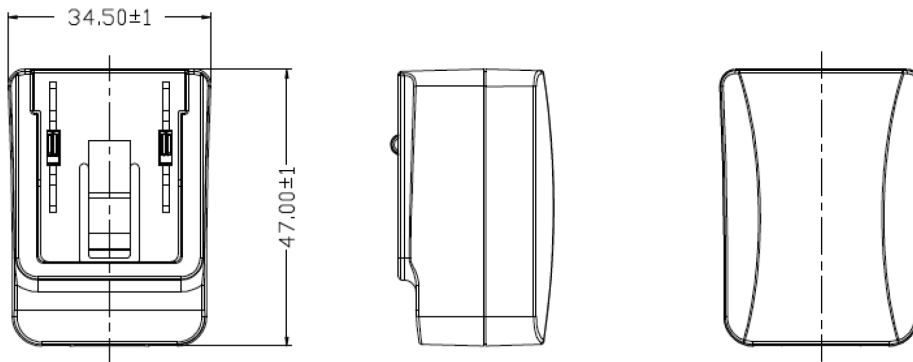

| INTERCHANGEABLE BLADES |               |          |          |           |          |
|------------------------|---------------|----------|----------|-----------|----------|
| BLADE DESIGNATOR       | N             | E        | B        | A         | C        |
| REGION                 | North America | Europe   | UK       | Australia | China    |
| BLADE ACCESSORY        | SMI-US-3      | SMI-EU-3 | SMI-UK-3 | SMI-AU-3  | SMI-CN-3 |
| BLADE                  |               |          |          |           |          |

## DC CORD

units: mm

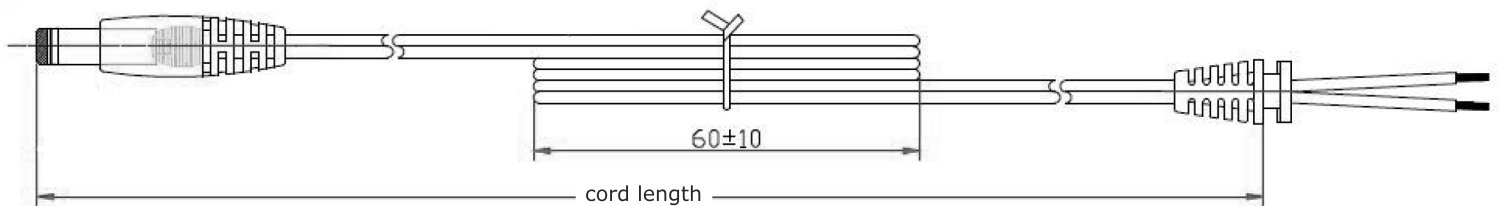
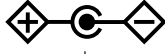

**Table 1**

| MODEL NO. | CABLE          | CORD LENGTH  |
|-----------|----------------|--------------|
| SMI6B-5   | UL2468, 22 AWG | 1,530 mm ±50 |
| SMI6B-6   | UL2468, 22 AWG | 1,530 mm ±50 |
| SMI6B-9   | UL2468, 24 AWG | 1,530 mm ±50 |
| SMI6B-12  | UL2468, 24 AWG | 1,530 mm ±50 |
| SMI6B-15  | UL2468, 24 AWG | 1,530 mm ±50 |

## DC PLUG TYPE PART NUMBER KEY

**XXX**

**Plug Polarity:**  
 P = Center Positive  
  
 N = Center Negative  

**Plug Code:**  
 X = Choose a code from the options below

**Plug Angle:**  
 "blank" = Straight  
 R = Right Angle

| Plug Polarity |             | Code   |                      | Dimensions (mm)  |      |     | Plug Angle |       |
|---------------|-------------|--------|----------------------|------------------|------|-----|------------|-------|
| Center Pos.   | Center Neg. | Option | Type                 | A                | B    | C   | Straight   | Right |
| •             | •           | 5      | Standard             | 5.5              | 2.1  | 9.5 | •          | •     |
| •             | •           | 6      | Standard             | 5.5              | 2.5  | 9.5 | •          | •     |
| •             | •           | 7      | Standard             | 3.5              | 1.35 | 9.5 | •          | •     |
| •             | •           | 10     | Locking <sup>2</sup> | 5.5              | 2.1  | 9.5 | •          | N/A   |
| •             | •           | 11     | Locking <sup>2</sup> | 5.5              | 2.5  | 9.5 | •          | N/A   |
| •             | •           | 12     | EIAJ-1               | 2.35             | 0.7  | 9.5 | •          | •     |
| •             | •           | 13     | EIAJ-2               | 4.0              | 1.7  | 9.5 | •          | •     |
| •             | •           | 14     | EIAJ-3               | 4.75             | 1.7  | 9.5 | •          | •     |
| N/A           | N/A         | CUB    | USB                  | USB Type C       |      |     | •          | N/A   |
| N/A           | N/A         | MUB    | USB                  | Micro USB Type B |      |     | •          | N/A   |

Note: 1. Contact CUI for additional plug options  
 2. Maximum insertion depth is 10mm

### Standard

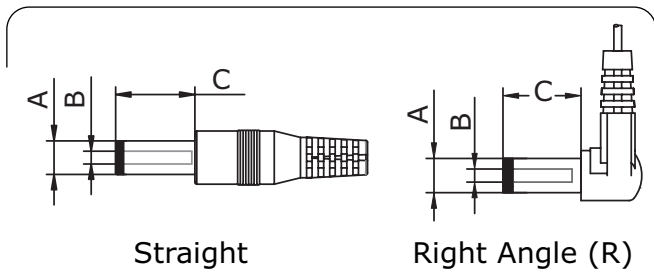

### EIAJ

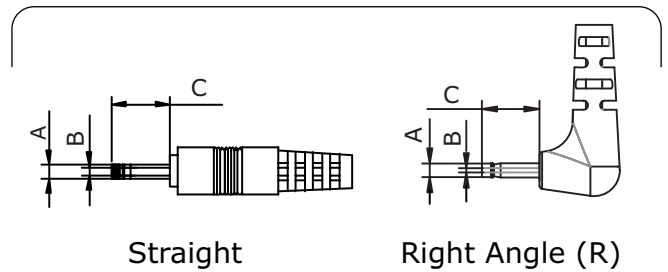

### Locking

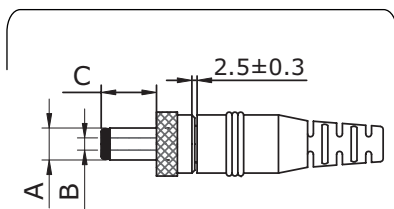

### USB

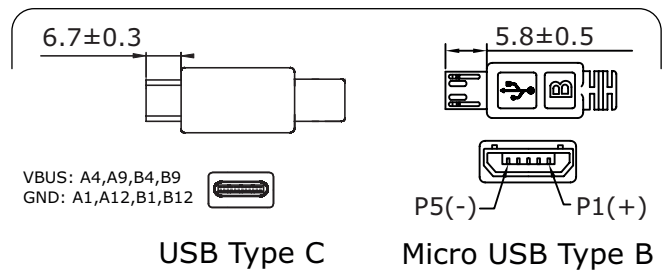

## REVISION HISTORY

| rev. | description                   | date       |
|------|-------------------------------|------------|
| 1.0  | initial release               | 06/04/2019 |
| 1.01 | company logo updated          | 09/30/2020 |
| 1.02 | model table updated           | 11/27/2020 |
| 1.03 | UKCA added to spec            | 08/10/2021 |
| 1.04 | plug polarity symbols updated | 09/16/2021 |
| 1.05 | dc plugs updated              | 04/24/2022 |
| 1.06 | ac blade clip type added      | 06/23/2022 |
| 1.07 | datasheet updated             | 11/19/2024 |

The revision history provided is for informational purposes only and is believed to be accurate.



# CUI INC

a bel group

#### Headquarters

15575 SW Sequoia Pkwy #100  
Portland, OR 97224  
**800.275.4899**

Fax 503.612.2383

**cui.com**

techsupport@cui.com

This device complies with part 15 of the FCC Rules. Operation is subject to the following two conditions:

- (1) This device may not cause harmful interference, and
- (2) this device must accept any interference received, including interference that may cause undesired operation.

CUI offers a one (1) year limited warranty. Complete warranty information is listed on our website.

CUI reserves the right to make changes to the product at any time without notice. Information provided by CUI is believed to be accurate and reliable. However, no responsibility is assumed by CUI for its use, nor for any infringements of patents or other rights of third parties which may result from its use.

CUI products are not authorized or warranted for use as critical components in equipment that requires an extremely high level of reliability. A critical component is any component of a life support device or system whose failure to perform can be reasonably expected to cause the failure of the life support device or system, or to affect its safety or effectiveness.