

**SERIES: PYBE20 | DESCRIPTION: DC-DC CONVERTER**

**FEATURES**

- up to 20 W isolated output
- industry standard pin-out
- 4:1 input range (9~36 Vdc, 18~75 Vdc)
- single/dual regulated outputs
- 1500 Vdc isolation
- continuous short circuit protection
- efficiency up to 90%
- operating temperature range (-40~+85°C)
- EN/BS EN 62368-1



MODEL	input voltage		output voltage (Vdc)	output current		output power max (W)	ripple & noise <sup>1</sup> max (mVp-p)	efficiency <sup>2</sup> typ (%)
	typ (Vdc)	range (Vdc)		min (mA)	max (mA)			
PYBE20-Q24-S3 <sup>3</sup>	24	9~36	3.3	0	5000	16.5	100	86
PYBE20-Q24-S5 <sup>3</sup>	24	9~36	5	0	4000	20	100	88
PYBE20-Q24-S9 <sup>3</sup>	24	9~36	9	0	2222	20	100	89
PYBE20-Q24-S12 <sup>3</sup>	24	9~36	12	0	1667	20	100	89
PYBE20-Q24-S15 <sup>3</sup>	24	9~36	15	0	1333	20	100	90
PYBE20-Q24-S24 <sup>3</sup>	24	9~36	24	0	834	20	100	90
PYBE20-Q24-D5 <sup>3</sup>	24	9~36	±5	0	±2000	20	100	86
PYBE20-Q24-D9 <sup>3</sup>	24	9~36	±9	0	±1111	20	100	88
PYBE20-Q24-D12 <sup>3</sup>	24	9~36	±12	0	±834	20	100	88
PYBE20-Q24-D15 <sup>3</sup>	24	9~36	±15	0	±667	20	100	88
PYBE20-Q48-S3	48	18~75	3.3	0	5000	16.5	100	86
PYBE20-Q48-S5	48	18~75	5	0	4000	20	100	86
PYBE20-Q48-S9	48	18~75	9	0	2222	20	100	89
PYBE20-Q48-S12	48	18~75	12	0	1667	20	100	87
PYBE20-Q48-S15	48	18~75	15	0	1333	20	100	90
PYBE20-Q48-S24	48	18~75	24	0	834	20	100	88
PYBE20-Q48-D5	48	18~75	±5	0	±2000	20	100	86
PYBE20-Q48-D12	48	18~75	±12	0	±834	20	100	88
PYBE20-Q48-D15	48	18~75	±15	0	±667	20	100	89

- Notes:
1. From 5~100% load, nominal input, 20 MHz bandwidth oscilloscope, with 10 µF tantalum and 1 µF ceramic capacitors on the output. From 0~5% load, ripple and noise is <5% Vo.
  2. Measured at nominal input voltage, full load. The typical efficiencies for the chassis mount and DIN-rail mount versions are ~2% less than the board mount versions due to the input reverse polarity protection.
  3. Model is not CE certified.
  4. All specifications are measured at Ta=25°C, humidity < 75%, nominal input voltage, and rated output load unless otherwise specified.

## PART NUMBER KEY

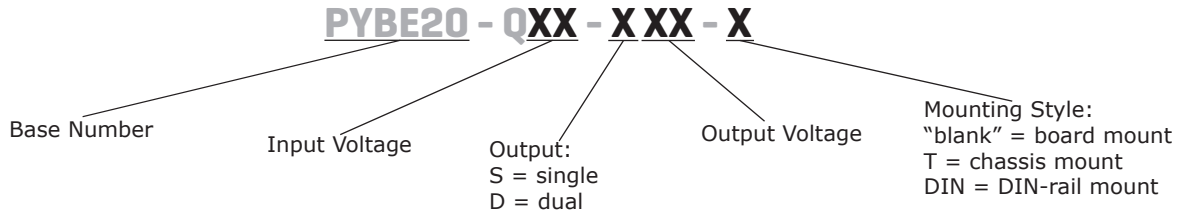

## INPUT

parameter	conditions/description	min	typ	max	units
operating input voltage	24 Vdc input models	9	24	36	Vdc
	48 Vdc input models	18	48	75	Vdc
start-up voltage	24 Vdc input models			9	Vdc
	48 Vdc input models			18	Vdc
surge voltage	for maximum of 1 second				
	24 Vdc input models	-0.7		50	Vdc
	48 Vdc input models	-0.7		100	Vdc
under voltage shutdown	24 Vdc input models	5.5	6.5		Vdc
	48 Vdc input models	12	15.5		Vdc
current	24 Vdc input models			818	mA
		3.3 Vdc output models		993	mA
		5 Vdc output models all other models		969	MA
	48 Vdc input models			409	mA
		3.3 Vdc output models		497	mA
		5 Vdc output models all other models		485	mA
remote on/off (CTRL) <sup>4</sup>	turn on (3.5~12 Vdc or open circuit) turn off (<1.2 Vdc) input current when switched off		4	7	mA
filter	Pi filter				
input reverse polarity protection	only present on chassis mount and DIN-rail mount models				
no load power consumption			0.15		W

Notes: 4. The voltage of the CTRL pin is referenced to input GND pin.

## OUTPUT

parameter	conditions/description	min	typ	max	units
maximum capacitive load <sup>5</sup>	3.3, 5 Vdc output models			10,000	μF
	9 Vdc output models			4,700	μF
	12 Vdc output models			1,600	μF
	24 Vdc output models			500	μF
	±5 Vdc output models			4,800	μF
	15, ±9 Vdc output models			1,000	μF
	±12 Vdc output models			800	μF
	±15 Vdc output models			625	μF
voltage accuracy <sup>6</sup>	0% to full load		±1	±3	%
line regulation	from low line to high line, full load				
	positive outputs		±0.2	±0.5	%
	negative outputs		±0.5	±1	%
load regulation <sup>7</sup>	from 5% to full load				
	positive outputs		±0.5	±1	%
	negative outputs		±0.5	±1.5	%

Note: 5. Tested at input voltage range and full load.

6. At 0~5% load, the max output voltage accuracy for the ±5 & ±9 Vdc output models is ±5%.

7. At 0~100% load, the max load regulation is ±5%.

**OUTPUT (CONTINUED)**

parameter	conditions/description	min	typ	max	units
cross regulation	dual output models: main output 50% load secondary output from 10~100% load			±5	%
start-up time	nominal input, constant resistive load		10		ms
adjustability <sup>8</sup>	see application notes		±10		%
switching frequency <sup>9</sup>	PWM mode		270		kHz
transient recovery time	25% load step change, nominal input voltage		300	500	µs
transient response deviation	25% load step change, nominal input voltage 3.3, 5, ±5 Vdc output models all other models		±5 ±3	±8 ±5	% %
temperature coefficient	at full load			±0.03	%/°C

Note: 8. For single output models only.

9. Value is based on full load. At loads &lt;50%, the switching frequency decreases with decreasing load

**PROTECTIONS**

parameter	conditions/description	min	typ	max	units
over voltage protection		110		160	%
over current protection		110		190	%
short circuit protection	hiccup, continuous, self recovery				

**SAFETY AND COMPLIANCE**

parameter	conditions/description	min	typ	max	units
isolation voltage	input to output for 1 minute at 1 mA	1,500			Vdc
isolation resistance	input to output at 500 Vdc	1,000			MΩ
isolation capacitance	input to output, 100 kHz / 0.1 V PYBE20-Q24-S24 all other models		2,050 1,050		pF pF
safety approvals <sup>10, 11</sup>	certified to 62368-1: EN, BS EN certified to 60950-1: UL				
conducted emissions	CISPR32/EN55032, class A (no external circuit); class B (external circuit required, see Figure 3-b, 4-b)				
radiated emissions	CISPR32/EN55032, class A (no external circuit); class B (external circuit required, see Figure 3-b, 4-b)				
ESD	IEC/EN61000-4-2, contact ± 4kV, class B				
radiated immunity	IEC/EN61000-4-3, 10V/m, class A				
EFT/burst	IEC/EN61000-4-4, ± 2kV, class B (external circuit required, see Figure 3-a, 4-a)				
surge	IEC/EN61000-4-5, line-line ± 2kV, class B (external circuit required, see Figure 3-a, 4-a)				
conducted immunity	IEC/EN61000-4-6, 3 Vr.m.s, class A				
voltage dips & interruptions	IEC/EN61000-4-29, 0%-70%, class B				
MTBF	as per MIL-HDBK-217F, 25°C	1,000,000			hours
RoHS	yes				

Note: 10. UL approval only for board mount models.

11. CE approval only applies for models that have 18~75 Vdc input range. Please refer to the model table.

## ENVIRONMENTAL

parameter	conditions/description	min	typ	max	units
operating temperature	see derating curves	-40		85	°C
storage temperature		-55		125	°C
storage humidity	non-condensing	5		95	%
vibration	10~55 Hz, for 30 minutes on each axis		10		G

## DERATING CURVES

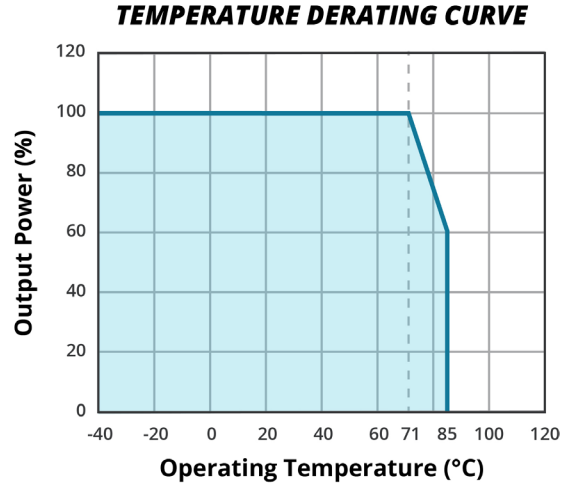

## SOLDERABILITY<sup>12</sup>

parameter	conditions/description	min	typ	max	units
hand soldering	1.5 mm from case for 10 seconds			300	°C
wave soldering	see wave soldering profile			260	°C

Note: 12. For board mount models only.

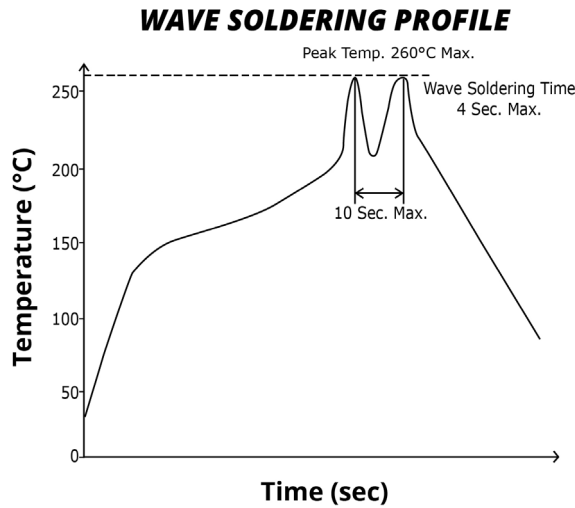

## MECHANICAL

parameter	conditions/description	min	typ	max	units
dimensions	board mount: 50.80 x 25.40 x 11.80 [2.000 x 1.000 x 0.465 inch]				mm
	chassis mount: 76.00 x 31.50 x 21.20 [2.992 x 1.240 x 0.835 inch]				mm
	DIN-rail mount: 76.00 x 31.50 x 25.80 [2.992 x 1.240 x 1.016 inch]				mm
case material	aluminum alloy				
weight	board mount		25		g
	chassis mount		48		g
	DIN-rail mount		68		g

## MECHANICAL DRAWING (BOARD MOUNT)

units: mm [inch]  
 tolerance: ±0.50[±0.020]  
 pin diameter tolerance: ±0.10[±0.004]

PIN CONNECTIONS		
PIN	Function	
	Single	Dual
1	GND	GND
2	Vin	Vin
3	+Vo	+Vo
4	trim	0V
5	0V	-Vo
6	CTRL	CTRL

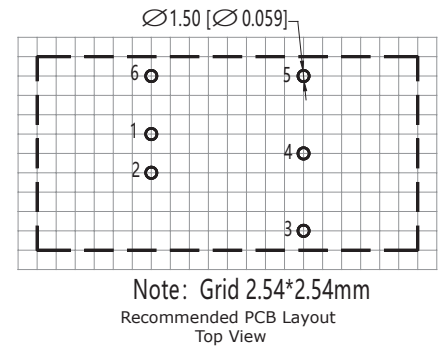
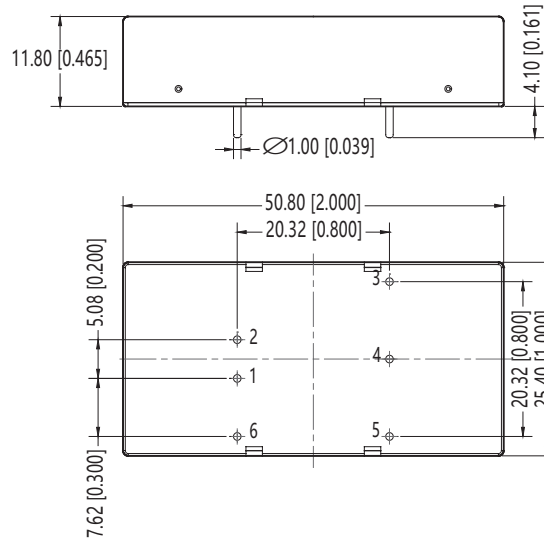

### MECHANICAL DRAWING (CHASSIS MOUNT)

units: mm [inch]  
tolerance: ±0.50[±0.020]

wire range: 24~12 AWG  
tightening torque: max 0.4 N\*m

PIN CONNECTIONS		
PIN	Function	
	Single	Dual
1	CTRL	CTRL
2	GND	GND
3	Vin	Vin
4	0V	-Vo
5	trim	0V
6	+Vo	+Vo

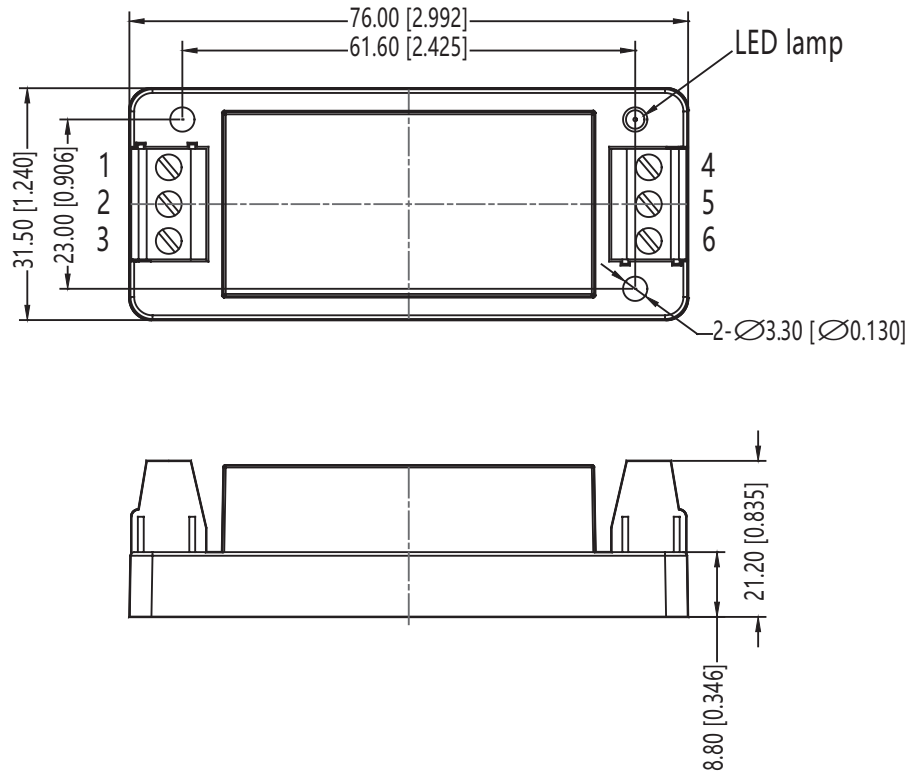

### MECHANICAL DRAWING (DIN-RAIL MOUNT)

units: mm [inch]  
tolerance: ±0.50[±0.020]

installed on DIN rail TS35  
wire range: 24~12 AWG  
tightening torque: max 0.4 N\*m

PIN CONNECTIONS		
PIN	Function	
	Single	Dual
1	CTRL	CTRL
2	GND	GND
3	Vin	Vin
4	0V	-Vo
5	trim	0V
6	+Vo	+Vo

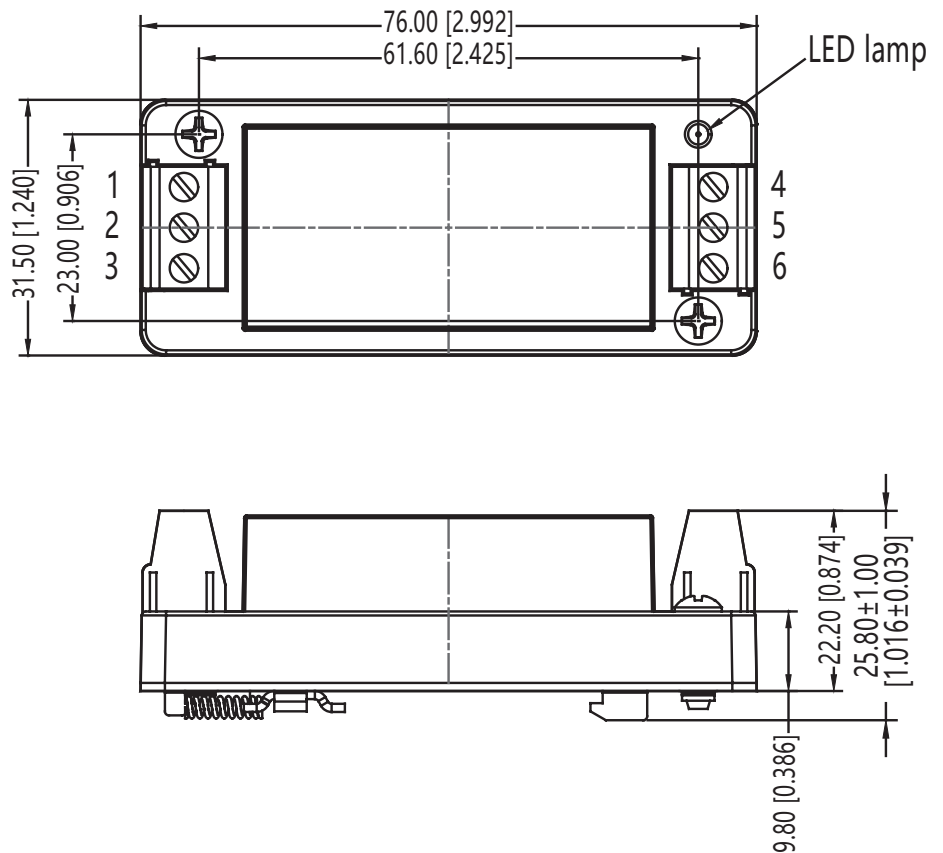

## APPLICATION CIRCUIT

This series has been tested according to the following recommended circuits (Figures 1 & 2) before leaving the factory. If you want to further reduce the input and output ripple, you can increase the input and output capacitors or select capacitors of low equivalent impedance provided that the capacitance is less than the maximum capacitive load of the model.

**Figure 1**  
Single Output Models

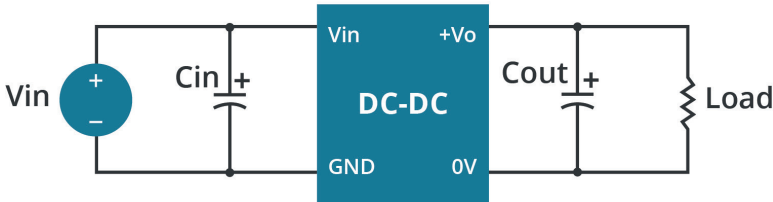

**Figure 2**  
Dual Output Models

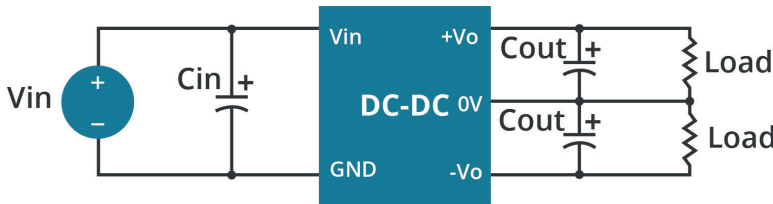
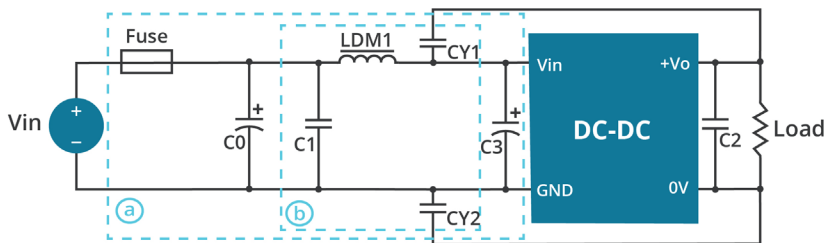

**Table 1**

Vout (Vdc)	Cin (μF)	Cout (μF)
3.3/5	100	470
9/12/15	100	220
24	100	100
±5	100	220
±9/±12/±15	100	100

## EMC RECOMMENDED CIRCUIT

**Figure 3**  
Single Output Models



**Figure 4**  
Dual Output Models

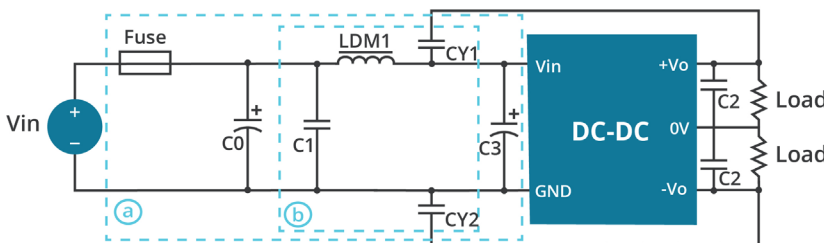

**Table 2**

Recommended External Circuit Components		
Vin (Vdc)	24	48
FUSE	choose according to actual input current	
C0, C3	330 μF / 50 V	330 μF / 100 V
C1	1 μF / 50 V	1 μF / 100 V
C2	Refer to the Cout in Table 1	
LDM1	4.7 μH / 3.1 A	
CY1, CY2	1 nF / 2 kV	

## APPLICATION NOTES

Output voltage trimming  
Leave open if not used.

Figure 3

Trim up

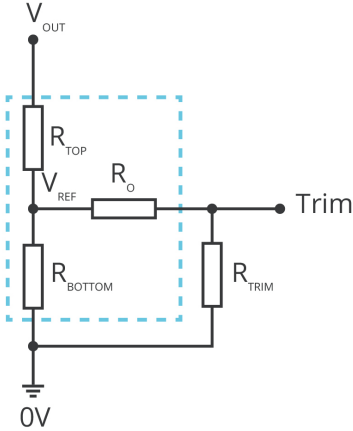

Trim down

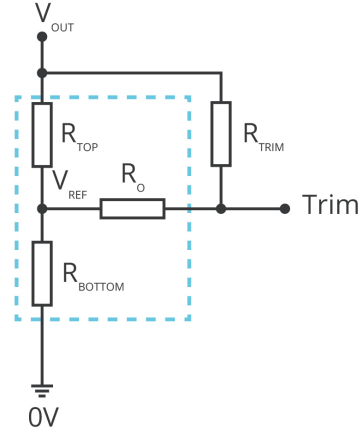

$$R_{TRIM} = \frac{a \cdot R_{BOTTOM}}{R_{BOTTOM} - a} - R_O \quad a = \frac{V_{REF}}{V_{OUT} - V_{REF}} \cdot R_{TOP}$$

Formula for Trim up

$$R_{TRIM} = \frac{a \cdot R_{TOP}}{R_{TOP} - a} - R_O \quad a = \frac{V_{OUT} - V_{REF}}{V_{REF}} \cdot R_{BOTTOM}$$

Formula for Trim down

Table 3

$V_{OUT}$	$R_{TOP}$	$R_{BOTTOM}$	$R_O$	$V_{REF}$
(Vdc)	(kΩ)	(kΩ)	(kΩ)	(V)
3.3	4.801	2.87	12.4	1.25
5	2.883	2.87	10	2.5
9	7.500	2.87	15	2.5
12	11.000	2.87	15	2.5
15	14.494	2.87	15	2.5
24	24.872	2.87	17.8	2.5

Note: Value for  $R_{TOP}$ ,  $R_{BOTTOM}$ ,  $R_O$ , and  $V_{REF}$  refer to Table 3 (fixed internal values).  
 $R_{TRIM}$ : Trim resistance  
 a: User-defined parameter, no actual meanings  
 $V_{OUT}$ : Nominal output voltage

## REVISION HISTORY

---

rev.	description	date
1.0	initial release	01/24/2019
1.01	features and safety line updated	01/12/2021
1.02	derating curve and circuit figures updated, packaging removed	08/23/2021
1.03	Vref updated for 3.3 Vdc output model	02/07/2022
1.04	CE certification updated for 24V models	12/21/2022
1.05	CE note updated in the safety & compliance section	11/10/2023

The revision history provided is for informational purposes only and is believed to be accurate.



**CUI INC**  
a bel group

**Headquarters**  
20050 SW 112th Ave.  
Tualatin, OR 97062  
**800.275.4899**

Fax 503.612.2383  
**cui.com**  
techsupport@cui.com

CUI offers a two (2) year limited warranty. Complete warranty information is listed on our website.

CUI reserves the right to make changes to the product at any time without notice. Information provided by CUI is believed to be accurate and reliable. However, no responsibility is assumed by CUI for its use, nor for any infringements of patents or other rights of third parties which may result from its use.

CUI products are not authorized or warranted for use as critical components in equipment that requires an extremely high level of reliability. A critical component is any component of a life support device or system whose failure to perform can be reasonably expected to cause the failure of the life support device or system, or to affect its safety or effectiveness.