

SERIES: PRQ150W | **DESCRIPTION:** DC-DC CONVERTER

FEATURES

- 150 W isolated output
- ¼-brick package with industry standard pin-out
- 4:1 ultra-wide input voltage range
- single regulated output
- high efficiency up to 91%
- output short circuit, over current, over voltage, & over temperature protection
- 2250 Vdc isolation
- EN 62368-1
- available with heat sink or base plate
- remote on/off control



MODEL

MODEL	input voltage		output voltage (Vdc)	output current max (A)	output power max (W)	ripple and noise ¹ max (mVp-p)	efficiency ² typ (%)
	typ (Vdc)	range (Vdc)					
PRQ150W-Q48-S5-D	48	18~75	5	30.0	150	250	88
PRQ150W-Q48-S12-D	48	18~75	12	12.5	150	250	91
PRQ150W-Q48-S15-D	48	18~75	15	10.0	150	250	89
PRQ150W-Q48-S24-D	48	18~75	24	6.25	150	250	91
PRQ150W-Q48-S48-D	48	18~75	48	3.13	150	250	91

Notes: 1. 20MHz bandwidth, nominal input, full load
2. Efficiency is measured in nominal input voltage and rated output load.

PART NUMBER KEY

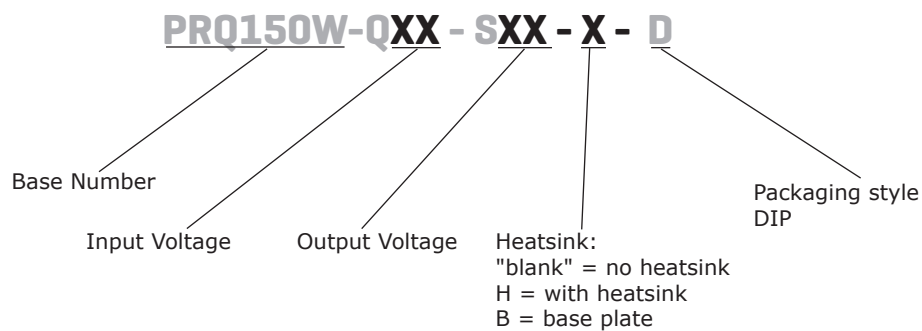

INPUT

parameter	conditions/description	min	typ	max	units
operating input voltage		18	48	80	Vdc
start-up voltage				18	Vdc
surge voltage	for maximum 1 second	-0.7		90	Vdc
remote on/off (CTRL) ¹	module ON: CTRL pin open or pulled high (3.5~12 Vdc) module OFF: CTRL pin pulled low to GND (0~1.2 Vdc)				
	input current when OFF		2	10	mA
filter	Pi filter				
current	full load/no load			3634/200	mA

Note: 1. The voltage of CTRL pin is relative to input pin GND.

OUTPUT

parameter	conditions/description	min	typ	max	units
maximum capacitive load	5 Vdc output models			6,000	μF
	12 Vdc & 15 Vdc output models			2,000	μF
	24 Vdc output models			1,000	μF
	48 Vdc output models			450	μF
line regulation	low line to high line		±0.2	±0.5	%
load regulation	5~100% load		±0.5	±0.75	%
set-point accuracy	0~100% load		±1	±3	%
switching frequency	PWM mode		250		kHz
transient response	25% load step change				
	5 Vdc output model all other output models		±3 ±3	±7.5 ±5	% %
temperature coefficient	full load			±0.03	%/°C
trim range		90		110	%
sense range				105	%

PROTECTIONS

parameter	conditions/description	min	typ	max	units
over voltage protection		110		160	%
over current protection		110		150	%
short circuit protection	continuous, auto recovery, hiccup				
over temperature protection			115	120	°C

SAFETY AND COMPLIANCE

parameter	conditions/description	min	typ	max	units
isolation voltage	input to output, 5mA for 1 minute	2,250			Vdc
	input to case, 5mA for 1 minute	1,500			Vdc
	output to case, 5mA for 1 minute	500			Vdc
isolation resistance	input-output at 500 Vdc	100			MΩ
isolation capacitance	input to output at 100 KHz/0.1 V		2,200		pF
safety approvals	certified to 62368: EN, BS EN				
conducted emissions	CISPR32/EN55032 CLASS A (see Fig. 2 for recommended circuit)				
radiated emissions	CISPR32/EN55032 CLASS A (see Fig. 2 for recommended circuit)				
ESD	IEC/EN61000-4-2, EN50121-3-2 Contact ±6KV Air ±8KV, perf. Criteria B				
radiated immunity	IEC/EN61000-4-3, EN50121-3-2 10V/m, perf. Criteria A				
EFT/burst	IEC/EN61000-4-4, EN50121-3-2 ±2KV, perf. Criteria A				
surge	EN50121-3-2 differential mode ±1KV, 1.2/50us, source impedance 42Ω, perf. Criteria B				
conducted immunity	IEC/EN61000-4-6, EN50121-3-2 10 Vr.m.s, perf. Criteria A				
MTBF	MIL-HDBK-217 at 25°C	500			kHours
RoHS	yes				

ENVIRONMENTAL

parameter	conditions/description	min	typ	max	units
operating temperature	see derating curve	-40		85	°C
storage temperature		-55		125	°C
storage humidity	non-condensing	5		95	%

SOLDERABILITY

pin soldering resistance	wave-soldering, 10 seconds			260	°C
temperature	soldering spot is 1.5 mm away from case for 10 seconds			300	°C

MECHANICAL

parameter	conditions/description	min	typ	max	units
dimensions	61.8 x 40.2 x 12.7				mm
	with base plate 62.0 x 56.0 x 14.6				mm
	with heat sink 61.8 x 40.2 x 27.7				mm
case material	aluminum alloy case, black plastic bottom, flame-retardant and heat-resistant (UL94 V-0)				
weight			89		g
	with base plate		109		g
	with heat sink		120		g
cooling method	natural convection (20 LFM)				

MECHANICAL DRAWING

units: mm [inches]

pin 1,2,3,5,6,7's diameter: 1.00 [0.039]

pin 4,8's diameter: 1.50 [0.059]

pin diameter tolerance: ± 0.10 [± 0.004]

general tolerance: ± 0.50 [± 0.020]

mounting hole screwing torque: Max 0.4 N·m

PIN CONNECTIONS	
PIN	FUNCTION
1	+Vin
2	CTRL
3	-Vin
4	0V
5	Sense-
6	Trim
7	Sense+
8	+Vo

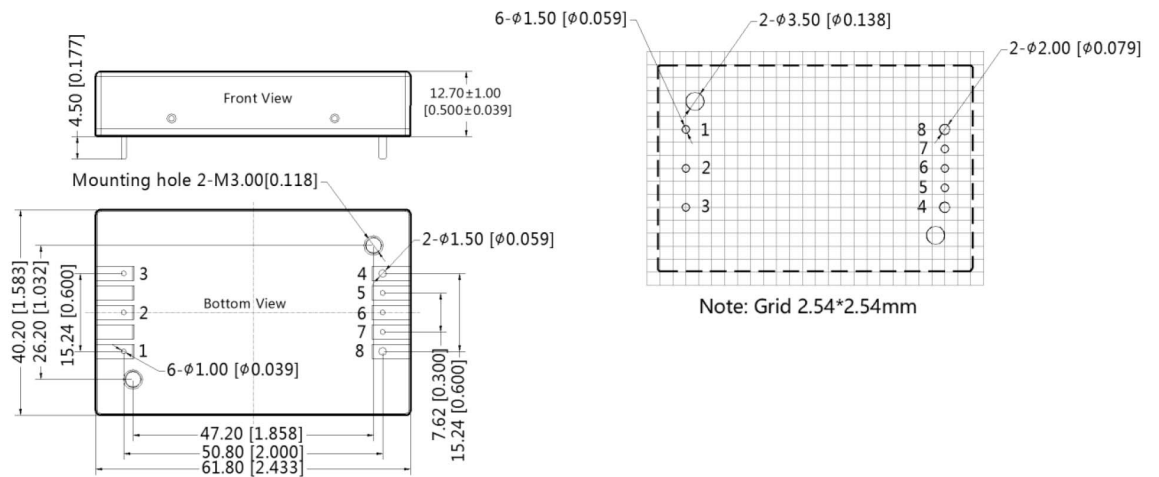

MECHANICAL DRAWING (CONTINUED)

with base plate

units: mm [inches]

pin 1,2,3,5,6,7's diameter: 1.00 [0.039]

pin 4,8's diameter: 1.50 [0.059]

pin diameter tolerance: ± 0.10 [± 0.004]

general tolerance: ± 0.50 [± 0.020]

mounting hole screwing torque: Max 0.4 N·m

PIN CONNECTIONS	
PIN	FUNCTION
1	+Vin
2	CTRL
3	-Vin
4	0V
5	Sense-
6	Trim
7	Sense+
8	+Vo

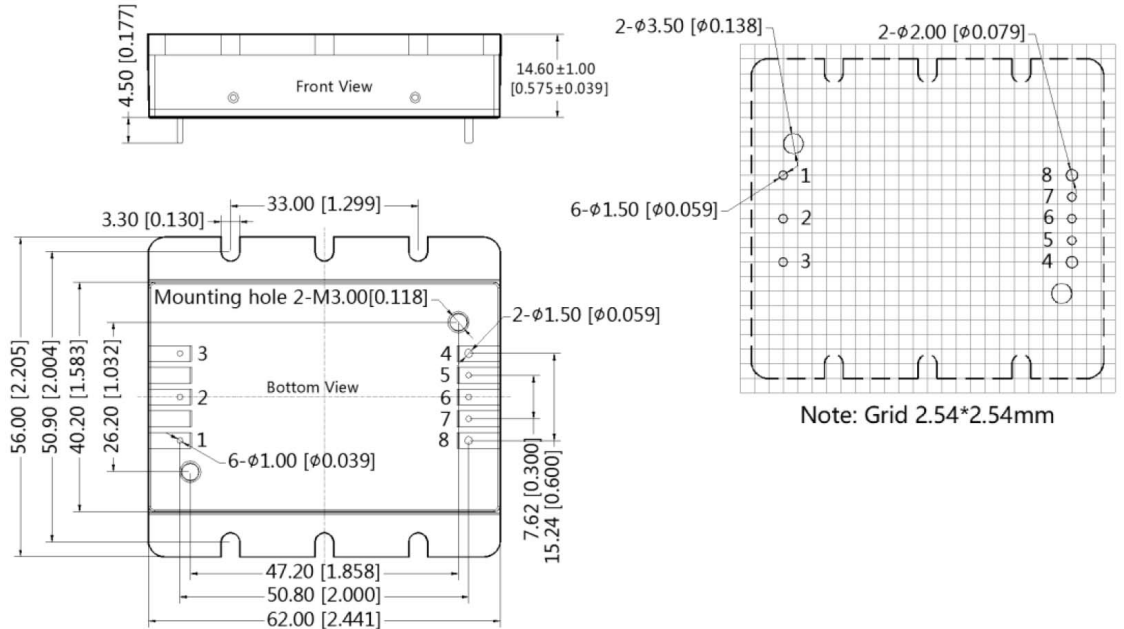

with heatsink

units: mm [inches]

pin 1,2,3,5,6,7's diameter: 1.00 [0.039]

pin 4,8's diameter: 1.50 [0.059]

pin diameter tolerance: ± 0.10 [± 0.004]

general tolerance: ± 0.50 [± 0.020]

mounting hole screwing torque: Max 0.4 N·m

PIN CONNECTIONS	
PIN	FUNCTION
1	+Vin
2	CTRL
3	-Vin
4	0V
5	Sense-
6	Trim
7	Sense+
8	+Vo

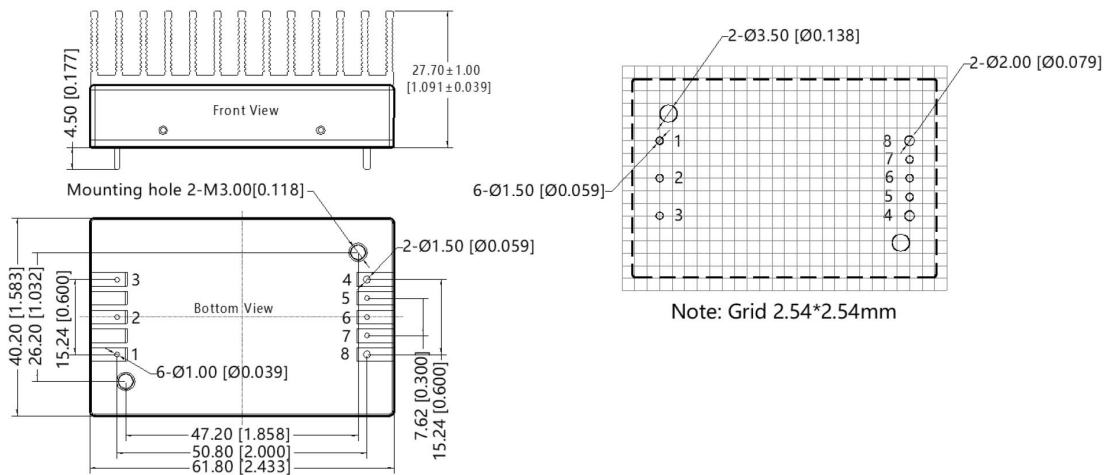

DERATING CURVES

TEMPERATURE DERATING CURVE
PRQ150W-Q48-S24-D (Baseplate version)
(Vin = 24 V)

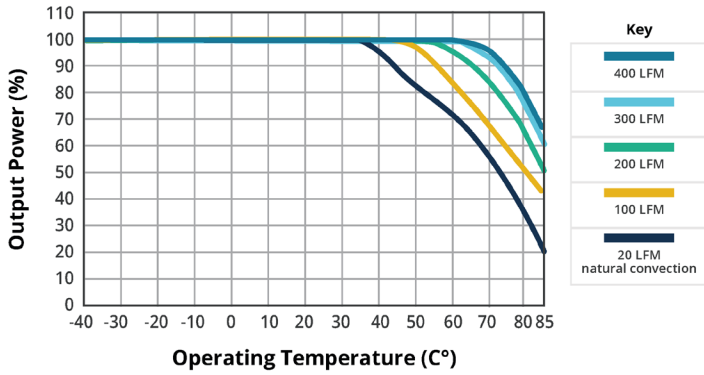

TEMPERATURE DERATING CURVE
PRQ150W-Q48-S24-H-D (Heatsink version)
(Vin = 24 V)

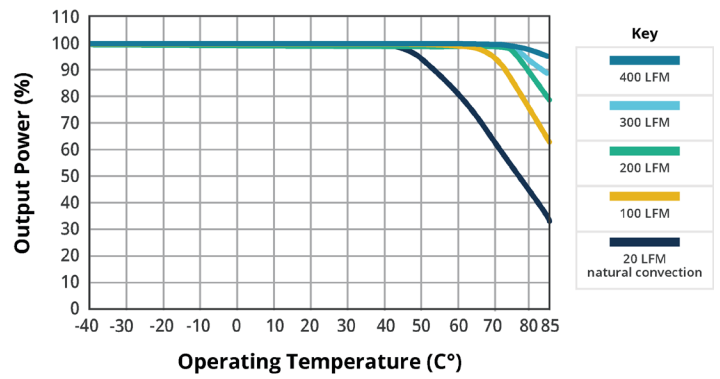

EFFICIENCY CURVES

EFFICIENCY VS INPUT VOLTAGE
(Full load)

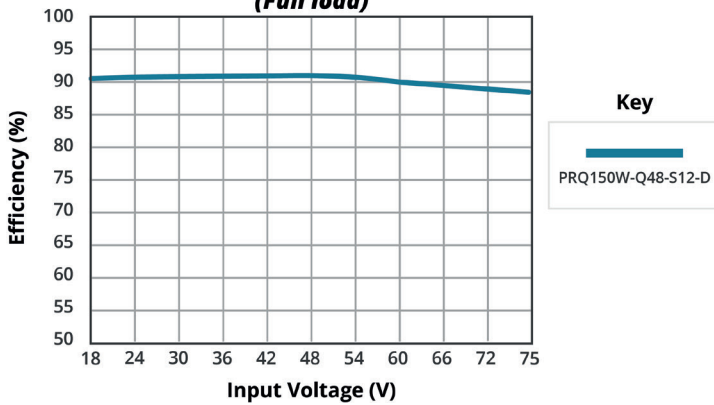

EFFICIENCY VS OUTPUT LOAD
(Vin = 48V)

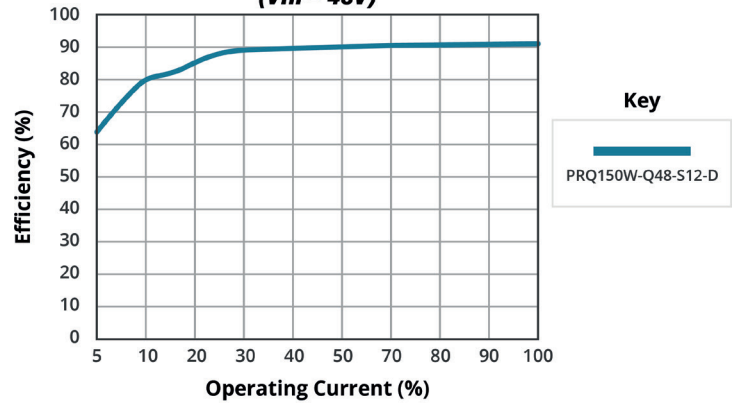

APPLICATION CIRCUIT

1. Let's change to: It is recommended to use the circuit shown in Fig. 1 during product testing and application, or otherwise ensure that at least 220 μF of electrolytic capacitors are connected at the input in order to ensure adequate voltage surge suppression and protection.
2. It is recommended to increase the value of C_{in} and pay attention to the unstable input voltage if the product input side is paralleled with motor drive circuit and/or larger energy transient circuits, to ensure the stability of input terminal and avoid repeatedly start-up problems due to input voltage lower than under-voltage protection point.
3. It is recommended to increase the output capacitance, limited to the capacitive load specification and/or increasing the voltage clamping circuit (such as TVS) if the output terminal is inductive device such as relay or a motor, to ensure adequate voltage surge suppression and protection.
4. Input and/or output ripple can be further reduced by appropriately increasing the input & output capacitor values C_{in} and C_{out} and/or by selecting capacitors with a low ESR (equivalent series resistance). Also make sure that the capacitance is not exceeding the specified maximum capacitive load value of the product.

Figure 1

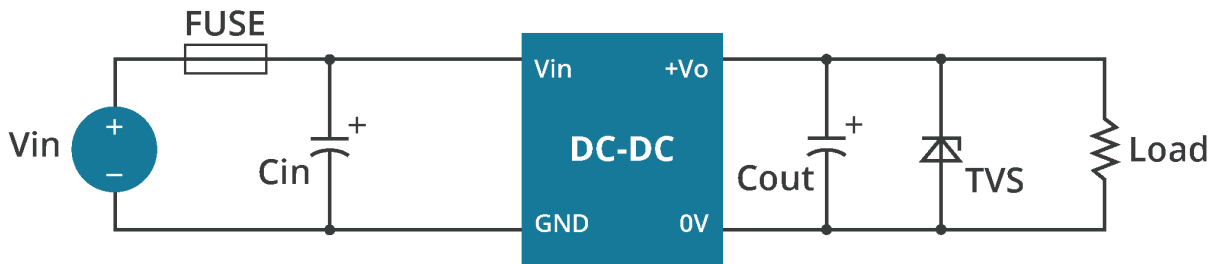

Table 1

Output voltage (Vdc)	FUSE	C_{in} (μF)	C_{out} (μF)	TVS
5	15A slow blow	220 μF	470 μF	SMDJ6.0A
12			220 μF	SMDJ14A
15				SMDJ17A
24			110 μF	SMDJ28A
48				SMDJ54A

Note: Please pay attention to the ambient temperature of the product when using an external capacitor, increase the electrolytic capacitor values to at least 1.5 times the original parameter if the ambient temperature is low (such as -25°C).

EMC RECOMMENDED CIRCUITS

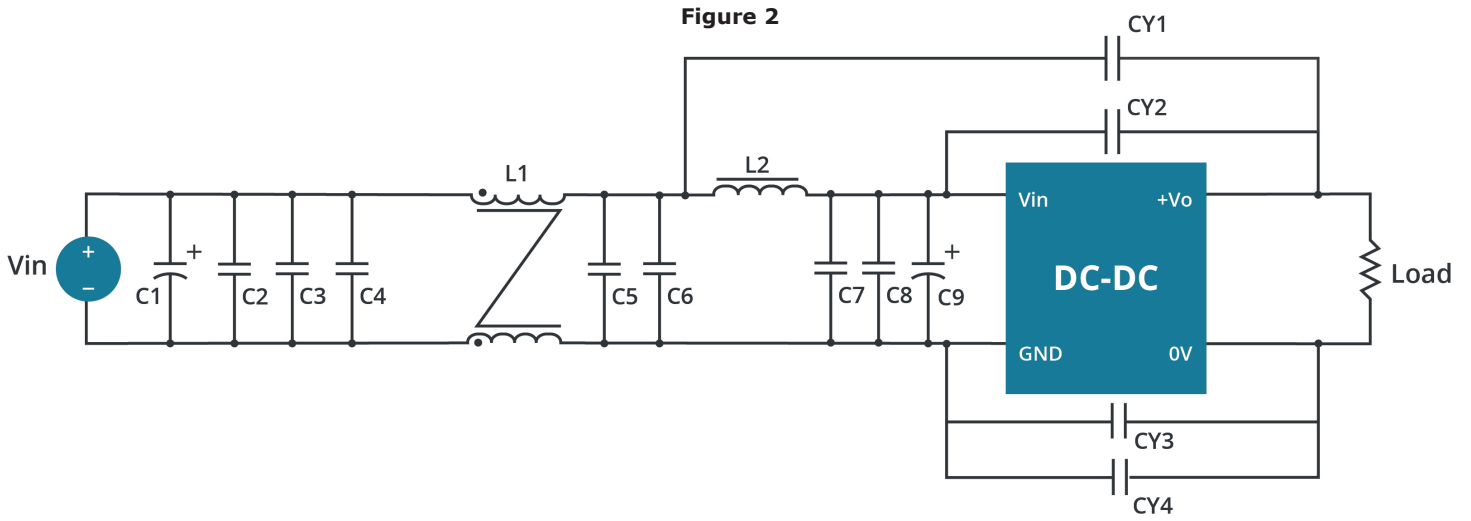

Table 2

List of Components	Recommended Component value
C1	150 μ F electrolytic capacitor
C9	47 μ F electrolytic capacitor
C2, C3, C4, C5, C6, C7, C8	2.2 μ F/100V ceramic capacitor
L1	1.0mH/15A common mode inductor
L2	1.5 μ F/15A inductance
CY1, CY2, CY3, CY4	1nF Y1 safety capacitor

APPLICATION NOTES

Figure 3

Trim up

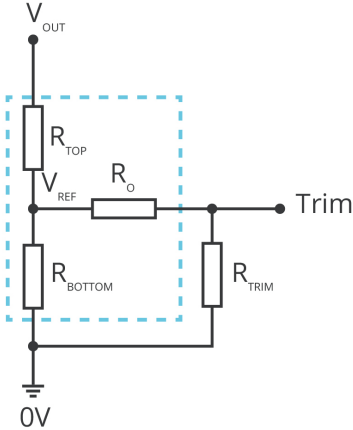

Trim down

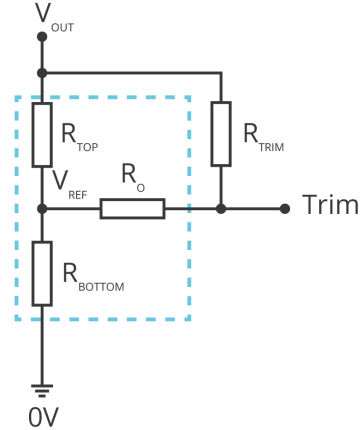

$$R_{TRIM} = \frac{a \cdot R_{BOTTOM}}{R_{BOTTOM} - a} - R_O \quad a = \frac{V_{REF}}{V_{OUT} - V_{REF}} \cdot R_{TOP}$$

Formula for Trim up

$$R_{TRIM} = \frac{a \cdot R_{TOP}}{R_{TOP} - a} - R_O \quad a = \frac{V_{OUT} - V_{REF}}{V_{REF}} \cdot R_{BOTTOM}$$

Formula for Trim down

Table 3

V _{NOM}	R _{TOP}	R _{BOTTOM}	R _O	V _{REF}
(Vdc)	(kΩ)	(kΩ)	(kΩ)	(V)
5	3.036	3.0	10	2.5
12	11.0	2.87	15	2.5
15	14.03	2.8	15	2.5
24	24.872	2.87	15	2.5
48	53.017	2.913	15	2.5

Note: Value for R_{TOP}, R_{BOTTOM}, R_O, and V_{REF} refer to Table 3 (fixed internal values).

R_{TRIM}: Trim resistance

a: User-defined parameter, no actual meanings

V_{NOM}: Nominal output voltage

V_{OUT}: Target output voltage

Note: When using the Trim down function make sure that the RT resistor value is calculated correctly. If the Trim pin is shorted with +Vo, or its value is too low, the or the output voltage Vo' would be lower than 0.9Vo, which may cause the product to fail.

REMOTE SENSE APPLICATION

Figure 4

REMOTE SENSE CONNECTION IF NOT USED

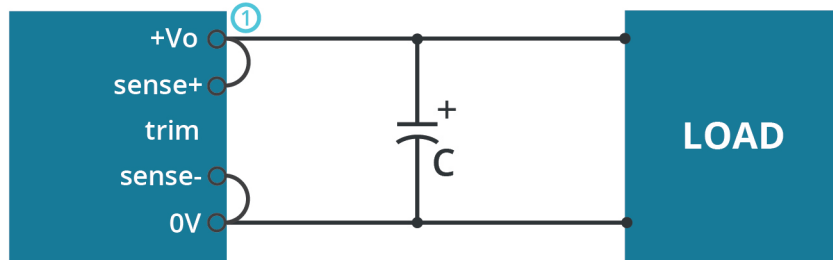

- Note:
1. Lines must be kept as short as possible.
 2. If the sense function is not used for remote regulation the user must connect the +Sense to +Vo and -Sense to 0V at the DC-DC converter pins and will compensate for voltage drop across pins only.
 3. The connections between Sense lines and their respective power lines must be kept as short as possible, otherwise they may be picking up noise, interference and/or causing unstable operation of the power module.

Figure 5

REMOTE SENSE CONNECTION USED FOR COMPENSATION

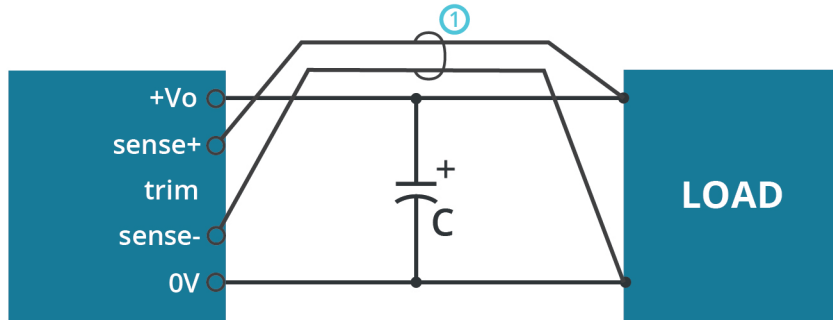

- Note:
1. In cables and discrete wiring applications, twisted pair or other techniques should be implemented.
 2. Using remote sense with long wires may cause unstable output, please contact technical support if long wires must be used
 3. PCB-tracks or cables/wires for Remote Sense must be kept as short as possible. Twisted pair or shielded wires are suggested for remote compensation and must be kept as short as possible.
 4. We recommend using adequate cross section for PCB-track layout and/or cables to connect the power supply module to the load in order to keep the voltage drop below 0.3V and to make sure the power supply's output voltage remains within the specified range.
 5. Note that large wire impedance may cause oscillation of the output voltage and/or increased ripple. Consult technical support or factory for further advice of sense operation.

REVISION HISTORY

rev.	description	date
1.0	initial release	10/25/2021
1.01	pin connections tables updated	04/04/2023

The revision history provided is for informational purposes only and is believed to be accurate.



Headquarters
20050 SW 112th Ave.
Tualatin, OR 97062
800.275.4899

Fax 503.612.2383
cuicom
techsupport@cuicom

CUI offers a two (2) year limited warranty. Complete warranty information is listed on our website.

CUI reserves the right to make changes to the product at any time without notice. Information provided by CUI is believed to be accurate and reliable. However, no responsibility is assumed by CUI for its use, nor for any infringements of patents or other rights of third parties which may result from its use.

CUI products are not authorized or warranted for use as critical components in equipment that requires an extremely high level of reliability. A critical component is any component of a life support device or system whose failure to perform can be reasonably expected to cause the failure of the life support device or system, or to affect its safety or effectiveness.