

INPUT

parameter	conditions/description	min	typ	max	units
input voltage	12 Vdc input models	9	12	18	Vdc
	24 Vdc input models	18	24	36	Vdc
start-up voltage	12 Vdc input models			9	Vdc
	24 Vdc input models			18	Vdc
surge voltage	for maximum of 1 second				
	12 Vdc input models	-0.7		25	Vdc
	24 Vdc input models	-0.7		50	Vdc
filter	capacitance filter				
current	12 Vdc input models		321/30	338/50	mA
	24 Vdc input models		156/20	165/40	mA

OUTPUT

parameter	conditions/description	min	typ	max	units
line regulation	min to max Vin		±0.2	±0.5	%
load regulation	5% ~ 100% load		±0.5	±1	%
set-point accuracy	5% ~ 100% load				
	positive outputs		±1	±3	%
	negative outputs		±3	±5	%
switching frequency	full load, nominal input		300		kHz
transient response	25% load step change		±2.5	±5	%
temperature coefficient	full load			±0.03	%/°C

PROTECTIONS

parameter	conditions/description	min	typ	max	units
short circuit protection	continuous, self-recovery				

SAFETY AND COMPLIANCE

parameter	conditions/description	min	typ	max	units
isolation voltage	input-output electric strength test for 1 minute	1500			Vdc
isolation resistance	input-output insulation at 500 Vdc	1000			MΩ
isolation capacitance	input-output capacitance at 100 KHz / 0.1 V		100		pF
safety approvals	designed to meet 62368: EN, BS EN				
EMC	CISPR32/EN55032 Class B (see recommended circuits)				
ESD	IEC/EN61000-4-2, Contact ±6K, perf. Criteria B				
radiated immunity	CISPR32/EN55032				
EFT/burst	IEC/EN61000-4-4, ±2KV, perf. Criteria B (see recommended circuits)				
surge	IEC/EN61000-4-5, line to line ±2KV, perf. Criteria B (see recommended circuits)				
conducted immunity	IEC/EN61000-4-6 3 Vrms				
RoHS	yes				
MTBF	MIL-HDBK-217F @ 25°C	1000			kHours

ENVIRONMENTAL

parameter	conditions/description	min	typ	max	units
operating temperature		-40		85	°C
storage temperature		-55		125	°C
humidity	non-condensing	5		95	%

SOLDERABILITY

parameter	conditions/description	min	typ	max	units
hand soldering	1.5 mm from case for 10 seconds			300	°C
reflow soldering	60 s max			245	°C

DERATING CURVE

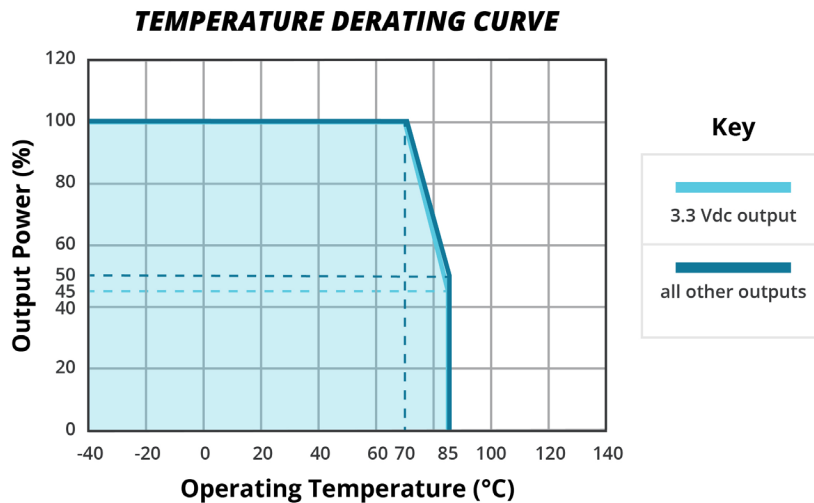

MECHANICAL

parameter	conditions/description	min	typ	max	units
dimensions	14 x 14 x 9				mm
case material	Black plastic; flame-retardant and heat-resistant (UL94-V0)				
weight			2.2		g

MECHANICAL DRAWING

units: mm [inches]
 pin diameter tolerance: ± 0.10 [±0.004]
 tolerance: ± 0.50 [±0.020]

PIN CONNECTIONS		
PIN	Single	Dual
1	GND	GND
4	Vin	Vin
5	+Vo	+Vo
6	NC	0V
7	0V	-Vo

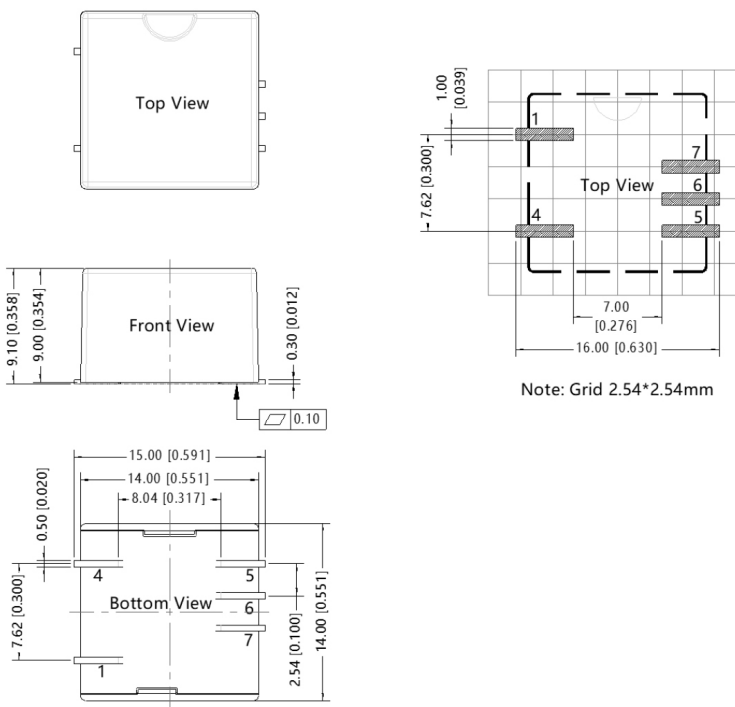

RECOMMENDED CIRCUITS

Figure 1
Single output

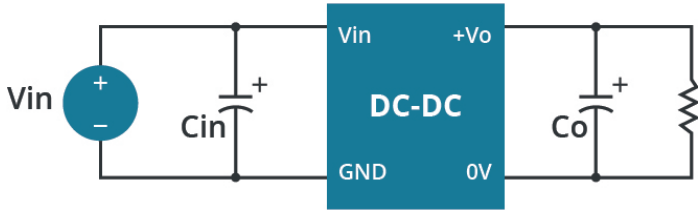

Parameter Description		
Vin (Vdc)	12	24
Cin	47uF/25V	47uF/50V
Vo (Vdc)	3.3, 5	12, 15, 24
Co	100uF/6.3V	27uF/35V

Figure 2
Dual output

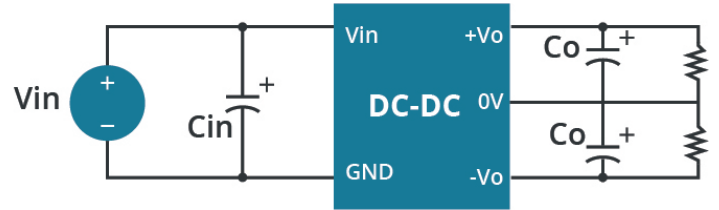

Parameter Description		
Vin (Vdc)	12	24
Cin	47uF/50V	
Vo (Vdc)	5, 9	12, 15
Co	47uF/16V	10uF/25V

EMC COMPLIANCE CIRCUITS

Figure 3
Single output

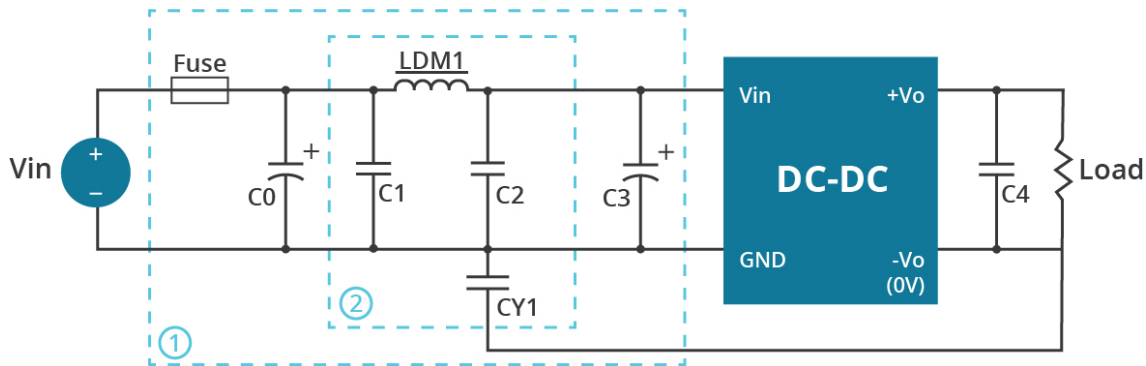

Parameter Description										
Part No.	Vin: 12 Vdc					Vin: 24 Vdc				
Vo (Vdc)	3.3	5	12	15	24	3.3	5	12	15	24
FUSE	slow blow, choose according to actual input current									
C0	1000µF/25V					680µF/50V				
C1	10µF/50V		4.7µF/50V			10µF/50V		4.7µF/50V		
LDM1	15µH									
C2	4.7µF/50V									
C3	330µF/50V									
CY1	1nF/2KV									
C4	Refer to the Cout Fig.2									

Note: For EMC tests we use Part ① in Fig. 3 for immunity and part ② for emissions test. Selecting based on needs.

EMC COMPLIANCE CIRCUITS (CONTINUED)

**Figure 4
Dual output**

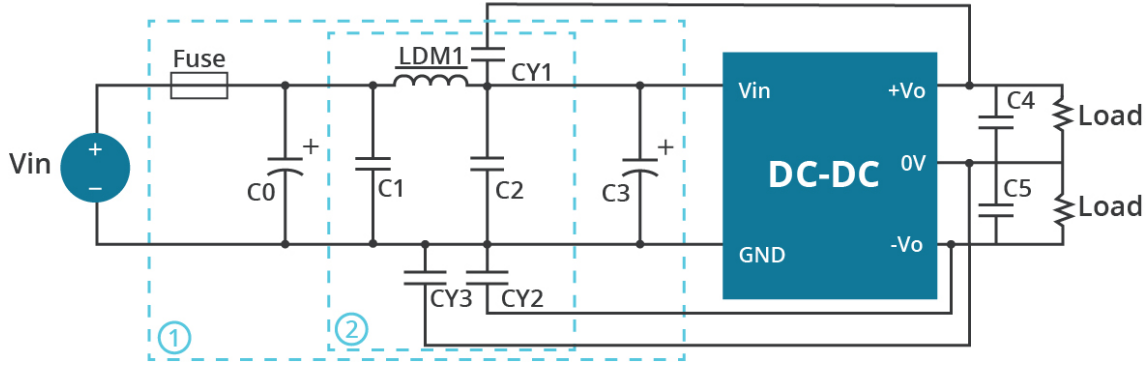

Parameter Description			
Part No.	Vin: 12 Vdc		Vin: 24 Vdc
Vo (Vdc)	±5, ±9, ±12	±15	±5, ±9, ±12, ±15
FUSE	slow blow, choose according to actual input current		
C0	1000µF/25V		680µF/50V
C1	4.7µF/50V		
LDM1	10µH		
C2	10µF/50V		
C3	330µF/50V		
CY1	1nF/2KV	470pF/2KV	1nF/2KV
CY2	1nF/2KV	470pF/2KV	1nF/2KV
CY3	1nF/2KV	470pF/2KV	/
C4,C5	Refer to the Cout Fig.3		

Note: For EMC tests we use Part ① in Fig. 4 for immunity and part ② for emissions test. Selecting based on needs.

REVISION HISTORY

rev.	description	date
1.0	initial release	03/28/2020
1.01	tolerance update to page 4	06/09/2020
1.02	derating curve and circuit figures updated	07/15/2021
1.03	CE certification removed	11/22/2022
1.04	dual output circuits added	05/31/2023

The revision history provided is for informational purposes only and is believed to be accurate.



Headquarters
20050 SW 112th Ave.
Tualatin, OR 97062
800.275.4899

Fax 503.612.2383
cui.com
techsupport@cui.com

CUI offers a two (2) year limited warranty. Complete warranty information is listed on our website.

CUI reserves the right to make changes to the product at any time without notice. Information provided by CUI is believed to be accurate and reliable. However, no responsibility is assumed by CUI for its use, nor for any infringements of patents or other rights of third parties which may result from its use.

CUI products are not authorized or warranted for use as critical components in equipment that requires an extremely high level of reliability. A critical component is any component of a life support device or system whose failure to perform can be reasonably expected to cause the failure of the life support device or system, or to affect its safety or effectiveness.