

INPUT

parameter	conditions/description	min	typ	max	units
input voltage	12 Vdc input models	9	12	18	Vdc
	24 Vdc input models	18	24	36	Vdc
start-up voltage	12 Vdc input models			9	Vdc
	24 Vdc input models			18	Vdc
surge voltage	for maximum of 1 second				
	12 Vdc input models	-0.7		25	Vdc
	24 Vdc input models	-0.7		50	Vdc
filter	capacitance filter				
current	12 Vdc input models		108/15	112/30	mA
	24 Vdc input models		54/6	56/12	mA

OUTPUT

parameter	conditions/description	min	typ	max	units
line regulation	min to max Vin				%
	positive output		±0.2	±0.5	
	negative output		±0.5	±1	
load regulation	5% ~ 100% load				%
	positive output		±0.5	±1	
	negative output			±2	
set-point accuracy	5% ~ 100% load				%
	positive outputs		±1	±3	%
	negative outputs		±3	±5	%
switching frequency	full load, nominal input		300		kHz
transient response	25% load step change		±3	±5	%
temperature coefficient	full load			±0.03	%/°C

PROTECTIONS

parameter	conditions/description	min	typ	max	units
short circuit protection	continuous, self-recovery				

SAFETY AND COMPLIANCE

parameter	conditions/description	min	typ	max	units
isolation voltage	input-output electric strength test for 1 minute	1500			Vdc
isolation resistance	input-output insulation at 500 Vdc	1000			MΩ
isolation capacitance	input-output capacitance at 100 KHz / 0.1 V		100		pF
safety approvals	designed to meet 62368: EN, BS EN				
EMC	CISPR32/EN55032 Class B (see recommended circuit)				
ESD	IEC/EN61000-4-2, Contact ±6K, perf. Criteria B				
radiated immunity	IEC/EN61000-4-3, 10 v/m, perf. Criteria A				
EFT/burst	IEC/EN61000-4-4, ±2KV, perf. Criteria B (see recommended circuit)				
surge	IEC/EN61000-4-5, line to line ±2KV, perf. Criteria B (see recommended circuit)				
conducted immunity	IEC/EN61000-4-6 3 Vrms, perf. Criteria A				
RoHS	yes				
MTBF	MIL-HDBK-217F @ 25°C	1000			kHours

ENVIRONMENTAL

parameter	conditions/description	min	typ	max	units
operating temperature		-40		85	°C
storage temperature		-55		125	°C
humidity	non-condensing	5		95	%

SOLDERABILITY

parameter	conditions/description	min	typ	max	units
hand soldering	1.5 mm from case for 10 seconds			300	°C
reflow soldering	60 s max over 217°C			245	°C

DERATING CURVE

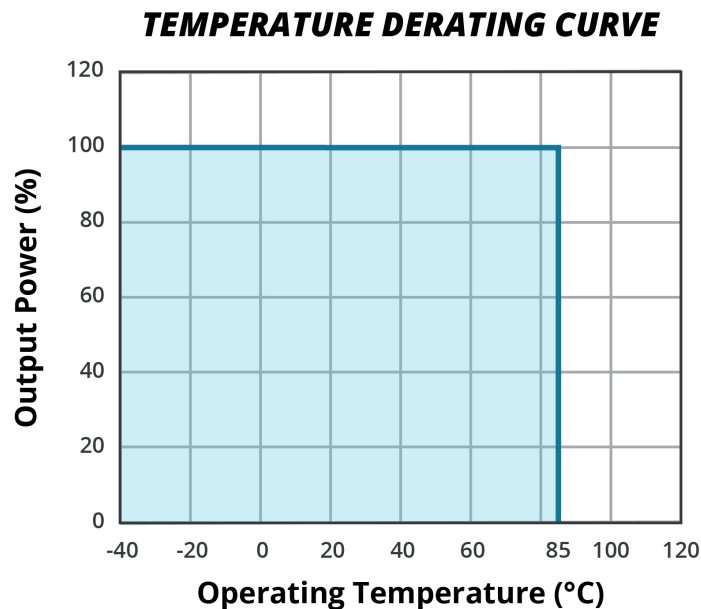

RECOMMENDED CIRCUITS

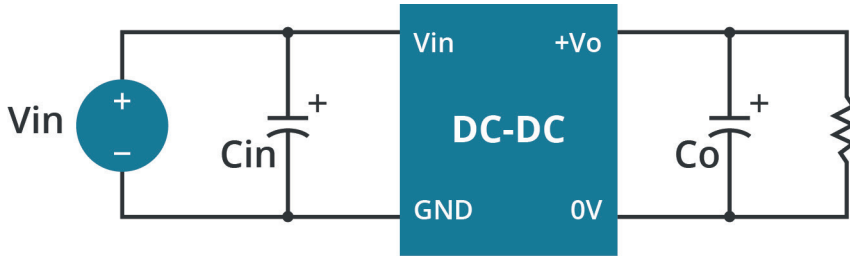

Parameter Description		
Vin (Vdc)	12	24
Cin	47uF/25V	47uF/50V
Vo (Vdc)	3.3, 5	12, 15, 24
Cout	100uF/6.3V	27uF/35V

EMC COMPLIANCE CIRCUITS

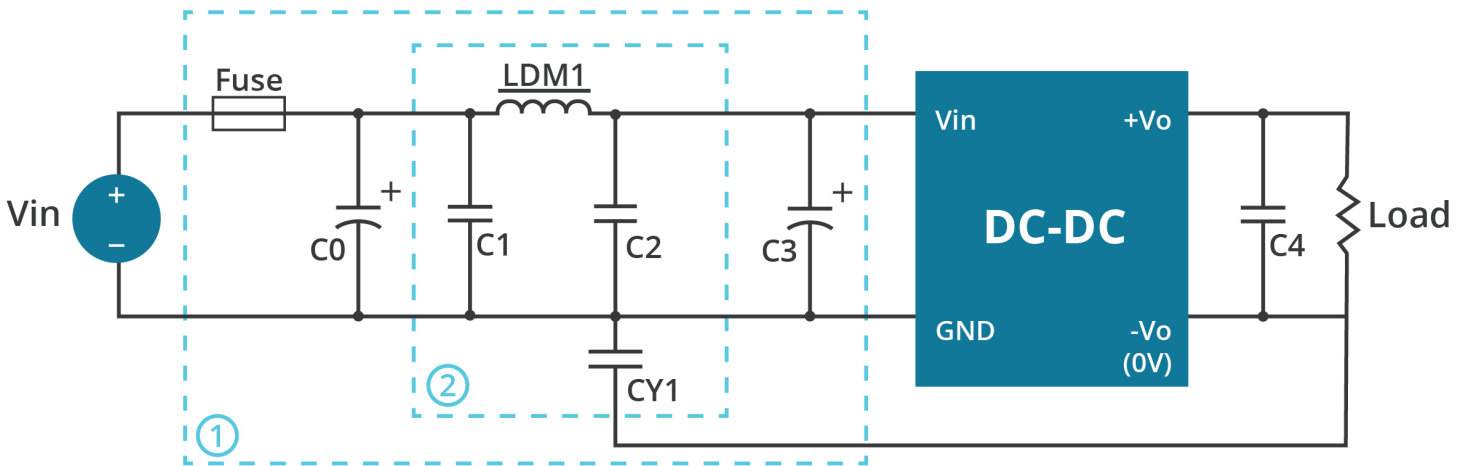

Parameter Description		
Part No.	Vin: 12 Vdc	Vin: 24 Vdc
FUSE	slow blow, choose according to actual input current	
C0	1000μF/25V	680μF/50V
C1	4.7μF/50V	
LDM1	15μH	
C2	4.7μF/50V	
C3	330μF/50V	
CY1	1nF/2KV	
C4	Refer to the Cout Fig.2	

REVISION HISTORY

rev.	description	date
1.0	initial release	03/28/2020
1.01	measurements updated	10/30/2020
1.02	derating curve and circuit figures updated	06/30/2021
1.03	CE certification removed	11/22/2022

The revision history provided is for informational purposes only and is believed to be accurate.



Headquarters
20050 SW 112th Ave.
Tualatin, OR 97062
800.275.4899

Fax 503.612.2383
cui.com
techsupport@cui.com

CUI offers a two (2) year limited warranty. Complete warranty information is listed on our website.

CUI reserves the right to make changes to the product at any time without notice. Information provided by CUI is believed to be accurate and reliable. However, no responsibility is assumed by CUI for its use, nor for any infringements of patents or other rights of third parties which may result from its use.

CUI products are not authorized or warranted for use as critical components in equipment that requires an extremely high level of reliability. A critical component is any component of a life support device or system whose failure to perform can be reasonably expected to cause the failure of the life support device or system, or to affect its safety or effectiveness.