

**SERIES:** PQDE6W | **DESCRIPTION:** DC-DC CONVERTER

**FEATURES**

- industry standard footprint
- high efficiency up to 88%
- single and dual output models available
- board mount
- 1500 Vdc isolation
- industrial operating temp -40~+85 °C
- 4:1 wide input range
- input under voltage protection & over voltage protection
- over current protection
- EN/BS EN 62368-1 certified



MODEL	input voltage		output voltage (Vdc)	output current		output power max (W)	ripple & noise <sup>1</sup> max (mVp-p)	efficiency <sup>2</sup> typ (%)
	typ (Vdc)	range (Vdc)		min (mA)	max (mA)			
PQDE6W-Q24-S3 <sup>3</sup>	24	9~36	3.3	0	1500	4.95	85	79
PQDE6W-Q24-S5 <sup>3</sup>	24	9~36	5	0	1200	6	85	83
PQDE6W-Q24-S9 <sup>3</sup>	24	9~36	9	0	667	6	85	85
PQDE6W-Q24-S12 <sup>3</sup>	24	9~36	12	0	500	6	85	87
PQDE6W-Q24-S15 <sup>3</sup>	24	9~36	15	0	400	6	85	88
PQDE6W-Q24-S24 <sup>3</sup>	24	9~36	24	0	250	6	85	88
PQDE6W-Q24-D5 <sup>3</sup>	24	9~36	±5	0	±600	6	85	83
PQDE6W-Q24-D12 <sup>3</sup>	24	9~36	±12	0	±250	6	85	87
PQDE6W-Q24-D15 <sup>3</sup>	24	9~36	±15	0	±200	6	85	88
PQDE6W-Q24-D24 <sup>3</sup>	24	9~36	±24	0	±125	6	85	88
PQDE6W-Q48-S3	48	18~75	3.3	0	1500	4.95	85	79
PQDE6W-Q48-S5	48	18~75	5	0	1200	6	85	83
PQDE6W-Q48-S12	48	18~75	12	0	500	6	85	87
PQDE6W-Q48-S15	48	18~75	15	0	400	6	85	88
PQDE6W-Q48-S24	48	18~75	24	0	250	6	85	88
PQDE6W-Q48-D5	48	18~75	±5	0	±600	6	85	83
PQDE6W-Q48-D12	48	18~75	±12	0	±250	6	85	87
PQDE6W-Q48-D15	48	18~75	±15	0	±200	6	85	88

Notes: 1. From 5~100% load, nominal input, 20 MHz bandwidth oscilloscope, with 10 µF tantalum and 1 µF ceramic capacitors on the output. From 0~5% load, ripple and noise is <5% Vo.  
 2. Measured at nominal input voltage, full load.  
 3. Model is not CE certified.  
 4. All specifications are measured at Ta=25°C, humidity < 75%, nominal input voltage, and rated output load unless otherwise specified.

## PART NUMBER KEY

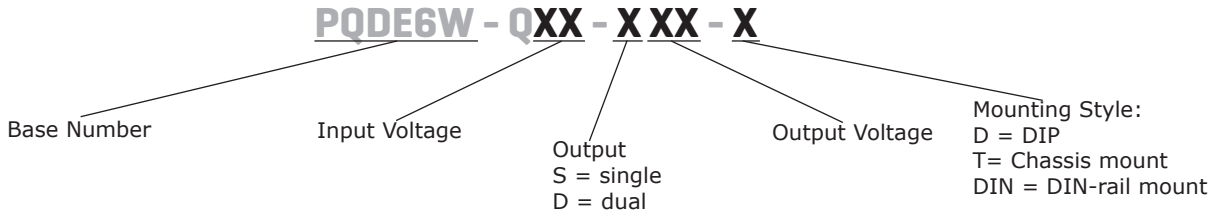

## INPUT

parameter	conditions/description	min	typ	max	units
operating input voltage	24 Vdc input models	9	24	36	Vdc
	48 Vdc input models	18	48	75	Vdc
start-up voltage	24 Vdc input models			9	Vdc
	48 Vdc input models			18	Vdc
surge voltage	for maximum of 1 second				
	24 Vdc input models	-0.7		50	Vdc
	48 Vdc input models	-0.7		100	Vdc
under voltage shutdown	24 Vdc input models	5.5	6.5		Vdc
	48 Vdc input models	12	15.5		Vdc
current	24 Vdc input models			268	mA
		3.3 Vdc output models		309	mA
		all other models			
	48 Vdc input models			134	mA
		3.3 Vdc output models		155	mA
		all other models			
filter	Pi filter				
input reverse polarity protection	only present on chassis mount and DIN-rail mount models				
no load power consumption			0.12		W

## OUTPUT

parameter	conditions/description	min	typ	max	units
maximum capacitive load <sup>1</sup>	3.3 Vdc output models			1,800	µF
	5 Vdc output models			1,000	µF
	9 Vdc output models			680	µF
	12, ±5 Vdc output models			470	µF
	15 Vdc output models			220	µF
	all other models			100	µF
voltage accuracy <sup>2</sup>	0% to full load		±1	±3	%
line regulation	from low line to high line, full load				
	positive outputs		±0.2	±0.5	%
	negative outputs		±0.5	±1	%
load regulation <sup>3</sup>	from 5% to full load				
	positive outputs		±0.5	±1	%
	negative outputs		±0.5	±1.5	%
voltage balance <sup>4</sup>	dual output models			±5	%
cross regulation	dual output models: main output 50% load secondary output from 10~100% load			±5	%
switching frequency <sup>5</sup>	PWM mode		300		kHz
transient recovery time	25% load step change, nominal input voltage		300	500	µs

**OUTPUT (CONTINUED)**

parameter	conditions/description	min	typ	max	units
transient response deviation	25% load step change, nominal input voltage		±5	±8	%
	3.3, 5, ±5 Vdc output models all other models		±3	±5	%
temperature coefficient	at full load			±0.03	%/°C

Note:

1. Tested at input voltage range and full load.
2. At 0~5% load, the max output voltage accuracy for the ±5 & ±9 Vdc output models is ±5%.
3. At 0~100% load, the max load regulation is ±5%.
4. Unbalanced loads should not exceed ±5%. If ±5% is exceeded, the product performance cannot be guaranteed.
5. Value is based on full load. At loads <50%, the switching frequency decreases with decreasing load.

**PROTECTIONS**

parameter	conditions/description	min	typ	max	units
over voltage protection		110		160	%
over current protection		110	140	190	%
short circuit protection	continuous, self recovery				

**SAFETY AND COMPLIANCE**

parameter	conditions/description	min	typ	max	units
isolation voltage	input to output for 1 minute at 1 mA	1,500			Vdc
isolation resistance	input to output at 500 Vdc	1,000			MΩ
isolation capacitance	input to output, 100 kHz / 0.1 V		1,000		pF
safety approvals	certified to 62368-1: EN/BS EN certified to 60950-1: UL				
conducted emissions	CISPR22/EN55022, class A (no external circuit); class B (external circuit required, see Figure 3-b)				
radiated emissions	CISPR22/EN55022, class A (no external circuit); class B (external circuit required, see Figure 3-b)				
ESD	IEC/EN61000-4-2, contact ± 4kV, class B				
radiated immunity	IEC/EN61000-4-3, 10V/m, class A				
EFT/burst	IEC/EN61000-4-4, ± 2kV, class B (external circuit required, see Figure 3-a)				
surge	IEC/EN61000-4-5, line-line ± 2kV, class B (external circuit required, see Figure 3-a)				
conducted immunity	IEC/EN61000-4-6, 3 Vr.m.s, class A				
voltage dips & interruptions	IEC/EN61000-4-29, 0%-70%, class B				
insulation grade <sup>6</sup>	functional				
MTBF	as per MIL-HDBK-217F, 25°C	1,000,000			hours
RoHS	yes				

Note: 6. Only suitable for class 1 energy sources (ES1).

**ENVIRONMENTAL**

parameter	conditions/description	min	typ	max	units
operating temperature	see derating curve	-40		85	°C
storage temperature		-55		125	°C
storage humidity	non-condensing	5		95	%
vibration	10~55 Hz for 30 minutes on each axis		10		G

## SOLDERABILITY

parameter	conditions/description	min	typ	max	units
hand soldering	1.5 mm from case for 10 seconds			300	°C
wave soldering	see wave soldering profile			260	°C

### WAVE SOLDERING PROFILE

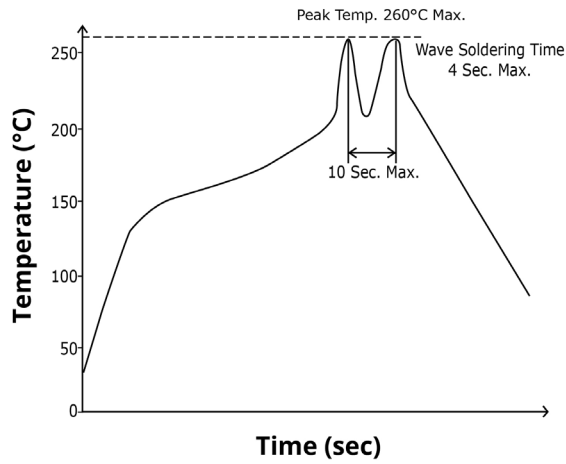

## DERATING CURVE

### TEMPERATURE DERATING CURVE

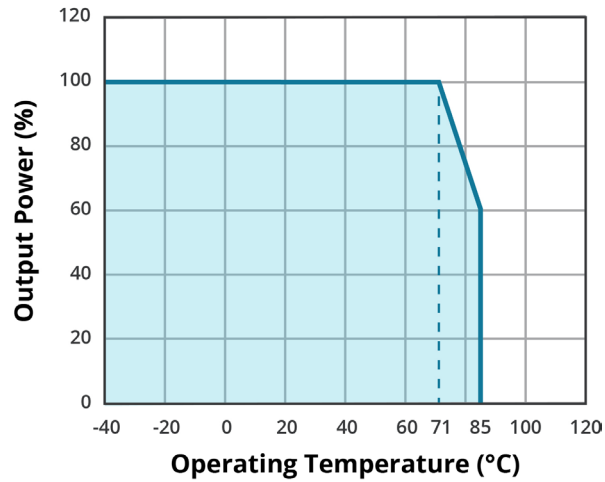

## EFFICIENCY CURVES

**EFFICIENCY VS INPUT VOLTAGE**  
(full load)

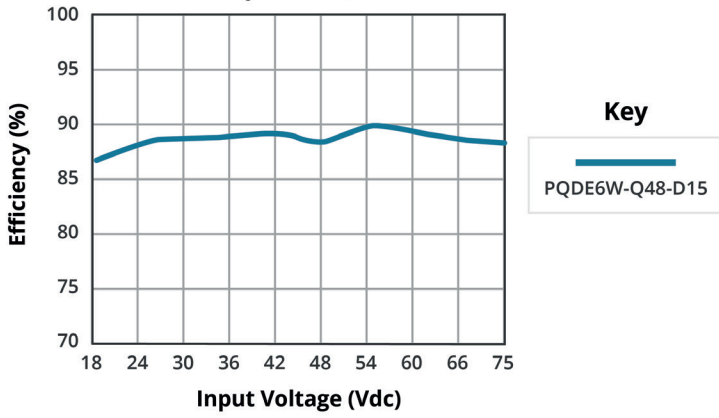

**EFFICIENCY VS OUTPUT LOAD**  
( $V_{in} = 48\text{ Vdc}$ )

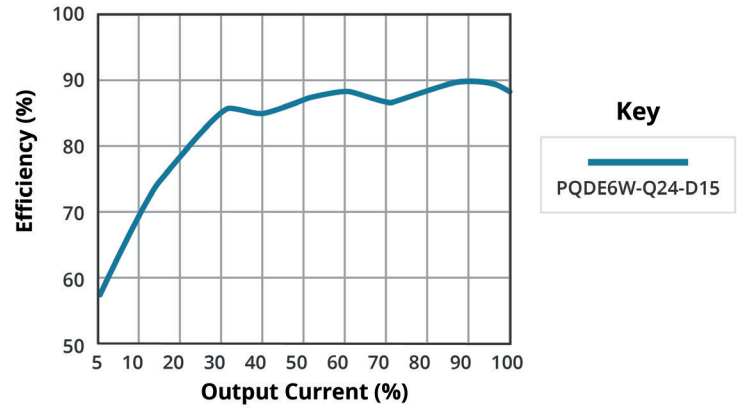

**EFFICIENCY VS INPUT VOLTAGE**  
(full load)

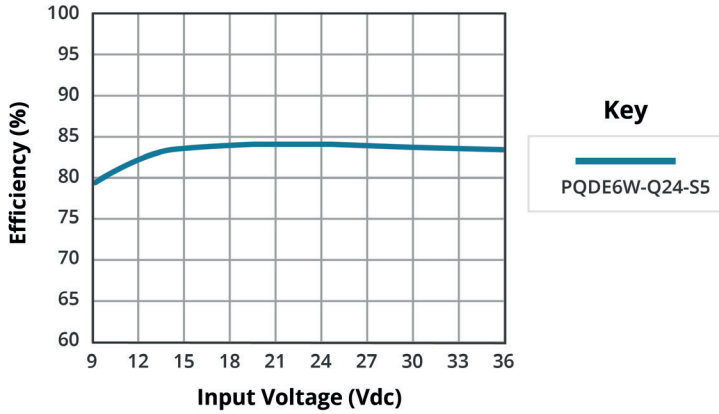

**EFFICIENCY VS OUTPUT LOAD**  
( $V_{in} = 24\text{ Vdc}$ )

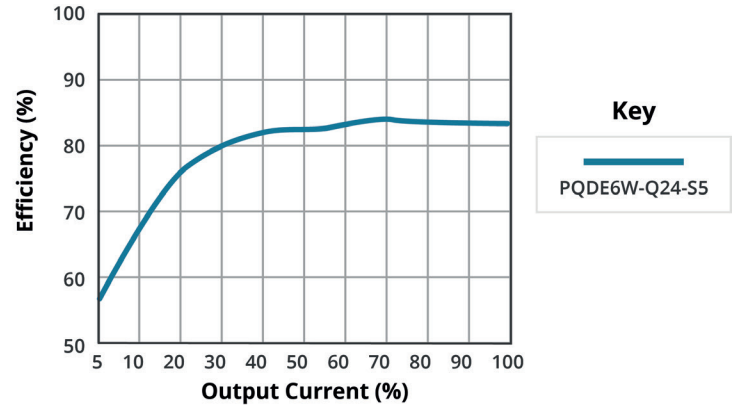

## MECHANICAL

parameter	conditions/description	min	typ	max	units
dimensions	DIP	25.40 x 25.40 x 11.70 [1.000 x 1.000 x 0.461 inch]			mm
	Chassis	76.00 x 31.50 x 21.20 [2.992 x 1.240 x 0.835 inch]			mm
	DIN-Rail	76.00 x 31.50 x 25.80 [2.992 x 1.240 x 1.016 inch]			mm
case material	aluminum alloy				
weight	DIP		14		g
	Chassis		36		g
	DIN-Rail		56		g

## MECHANICAL DRAWING

units: mm [inch]  
 tolerance:  $\pm 0.50 [\pm 0.020]$   
 pin diameter tolerance:  $\pm 0.10 [\pm 0.004]$

PIN CONNECTIONS		
PIN	Function	
	Single	Dual
1	GND	GND
2	Vin	Vin
3	+Vout	+Vout
4	No Pin	0V
5	0V	-Vout

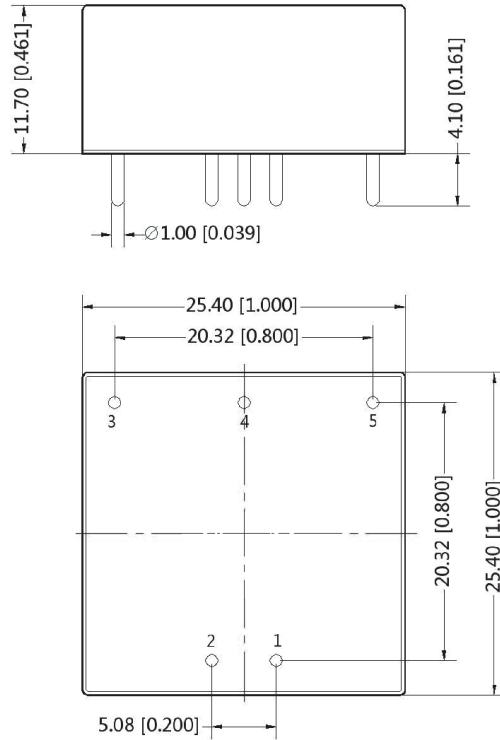

Note: 2.54 x 2.54 mm grid

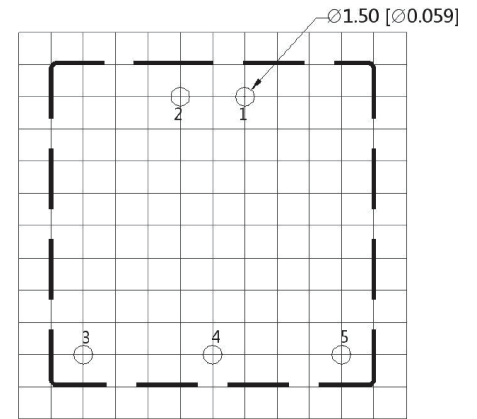

Recommended PCB Layout  
Top View

### MECHANICAL DRAWING (CHASSIS)

units: mm [inch]  
tolerance: ±0.50[±0.020]

wire range: 24~12 AWG  
tightening torque: max 0.4 N\*m

PIN CONNECTIONS		
PIN	Function	
	Single	Dual
1	NC	NC
2	GND	GND
3	Vin	Vin
4	0V	-Vout
5	NC	0V
6	+Vout	+Vout

NC=no connection

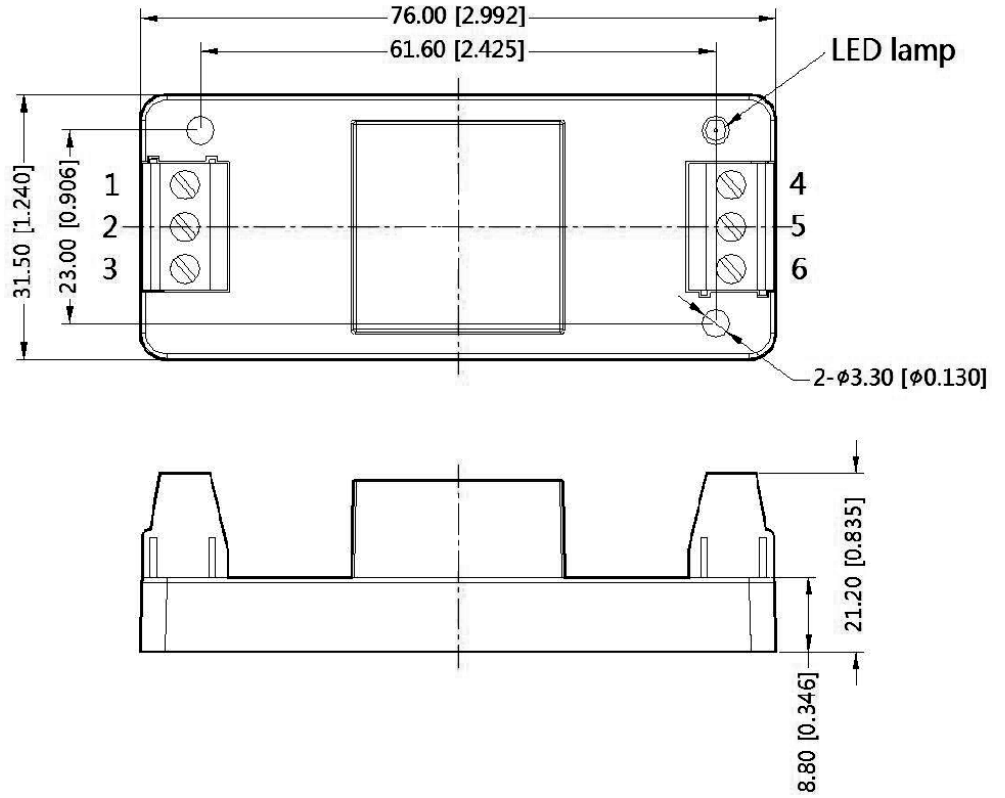

### MECHANICAL DRAWING (DIN-RAIL)

units: mm [inch]  
tolerance: ±0.50[±0.020]

installed on DIN rail TS35  
wire range: 24~12 AWG  
tightening torque: max 0.4 N\*m

PIN CONNECTIONS		
PIN	Function	
	Single	Dual
1	NC	NC
2	GND	GND
3	Vin	Vin
4	0V	-Vout
5	NC	0V
6	+Vout	+Vout

NC=no connection

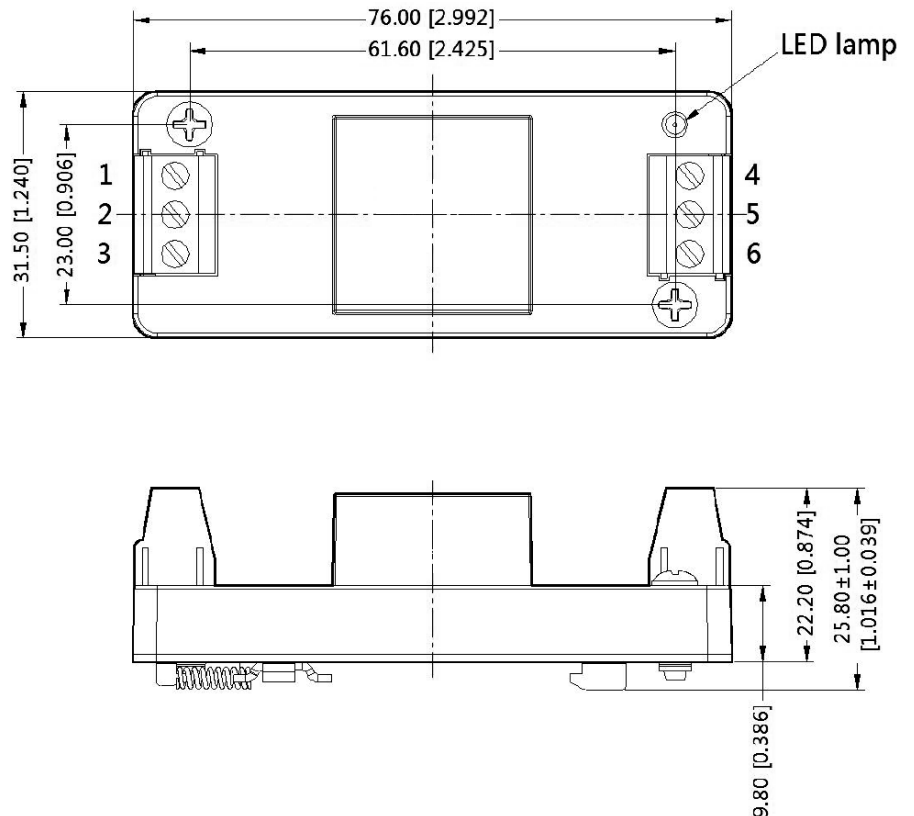

## APPLICATION CIRCUIT

This series has been tested according to the following recommended circuits (Figures 1 & 2) before leaving the factory. If you want to further reduce the input and output ripple, you can increase the input and output capacitors or select capacitors of low equivalent impedance provided that the capacitance is less than the maximum capacitive load of the model.

**Figure 1**  
Single Output Models

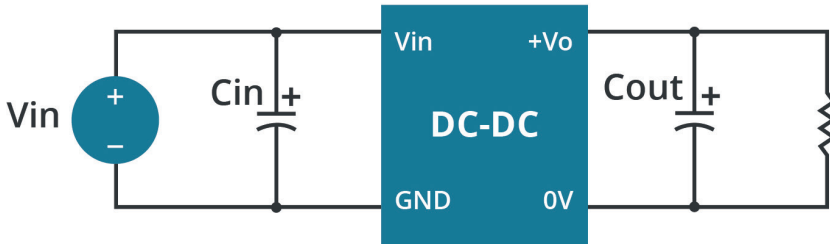

**Figure 2**  
Dual Output Models

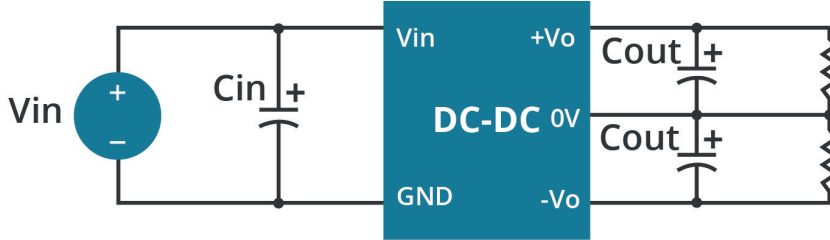
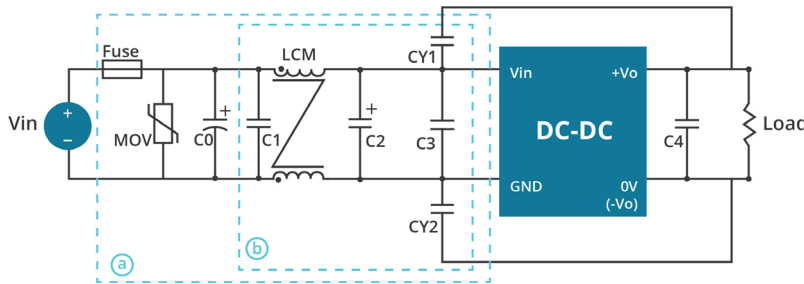

**Table 1**

Vin (Vdc)	Cin (μF/V)	Cout (μF/V)
24	100 μF/50 V	10 μF/50 V
48	10 μF ~ 47 μF / 100 V	10 μF/50 V

## EMC RECOMMENDED CIRCUIT

**Figure 3**



**Table 2**

Recommended External Circuit Components		
Vin (Vdc)	24	48
FUSE	choose according to actual input current	
MOV	S20K30	S14K60
C0	680 μF / 50 V	680 μF / 100 V
C1	1 μF / 50 V	1 μF / 100 V
C2	330 μF / 50 V	330 μF / 50 V
C3	4.7 μF / 50 V	4.7 μF / 100 V
C4	10 μF	
LCM	4.7 mH	
CY1, CY2	1 nF / 2 kV	

Notes: For EMC tests part ① in Figure 3 was used for immunity and part ② for emissions test. Selecting based on needs.



## REVISION HISTORY

---

rev.	description	date
1.0	initial release	02/20/2018
1.01	features and safety line updated, packaging removed	01/14/2021
1.02	derating curve and circuit figures updated	07/21/2021
1.03	chassis, din-rail models added	11/01/2022
1.04	CE certification updated	11/09/2022
1.05	safety section updated	03/15/2023
1.06	product photo updated	07/18/2023

The revision history provided is for informational purposes only and is believed to be accurate.



**CUI INC**

a bel group

**Headquarters**  
20050 SW 112th Ave.  
Tualatin, OR 97062  
**800.275.4899**

Fax 503.612.2383  
**cui.com**  
techsupport@cui.com

CUI offers a two (2) year limited warranty. Complete warranty information is listed on our website.

CUI reserves the right to make changes to the product at any time without notice. Information provided by CUI is believed to be accurate and reliable. However, no responsibility is assumed by CUI for its use, nor for any infringements of patents or other rights of third parties which may result from its use.

CUI products are not authorized or warranted for use as critical components in equipment that requires an extremely high level of reliability. A critical component is any component of a life support device or system whose failure to perform can be reasonably expected to cause the failure of the life support device or system, or to affect its safety or effectiveness.