

SERIES: F1C2-1111 | DESCRIPTION: HIGH POWER SHIELDED SMD INDUCTORS

FEATURES

- Magnetically shielded construction
- Unique metal dust core providing improved Isat
- Low DCR resulting in lower power losses



MODEL	Inductance (L ₀)	Tolerance	DC Resistance (DCR)	Saturation Current (Isat)		Temperature Rise Current (I _{rms})		E
	[μH]	[± %]	max [mΩ]	max [A]	typ [A]	max [A]	typ [A]	[± 0.5 mm]
F1C2-111103W-R28M	0.28	20	1.60	55.0	65.0	25.5	35.0	9.00
F1C2-111103W-R56M	0.56	20	2.75	39.0	44.0	23.0	32.0	9.00
F1C2-111103W-R82M	0.82	20	4.10	32.0	38.0	18.0	25.0	9.00
F1C2-111103W-R90M	0.90	20	4.20	31.0	36.0	17.0	24.0	9.00
F1C2-111103W-1R0M	1.00	20	4.95	30.0	35.0	16.0	23.0	9.00
F1C2-111103W-1R5M	1.50	20	6.60	23.0	28.0	12.0	18.0	9.00
F1C2-111106W-R68M	0.68	20	1.50	50.0	55.0	22.5	34.0	9.50
F1C2-111106W-1R0M	1.00	20	2.32	44.0	48.0	20.0	28.5	9.00
F1C2-111106W-1R2M	1.20	20	2.64	40.0	45.0	18.0	26.5	9.00
F1C2-111106W-1R5M	1.50	20	3.30	35.0	40.0	16.0	24.5	9.00
F1C2-111106W-2R2M	2.52	20	4.84	29.0	34.0	14.0	20.0	9.00
F1C2-111106W-3R3M	3.30	20	7.70	22.0	26.0	11.4	16.8	9.00
F1C2-111106W-4R7M	4.70	20	10.72	20.0	25.0	8.7	14.0	9.00
F1C2-111110W-2R2M	2.20	20	2.80	29.0	34.0	24.5	32.0	9.30
F1C2-111110W-3R3M	3.30	20	4.10	23.4	27.4	18.2	25.0	9.30
F1C2-111110W-4R7M	4.70	20	5.70	20.0	24.0	17.5	24.0	9.30
F1C2-111110W-5R6M	5.60	20	7.20	19.0	23.0	15.7	21.2	9.30
F1C2-111110W-6R8M	6.80	20	8.90	18.5	21.8	14.0	18.5	9.00
F1C2-111110W-8R2M	8.20	20	12.40	16.3	18.3	12.9	17.1	9.00
F1C2-111110W-100M	10.0	20	13.75	14.6	17.5	11.5	15.5	9.00
F1C2-111110W-150M	15.0	20	19.30	11.0	13.5	9.9	13.8	9.00

Notes:

1. Referenced ambient temperature 25°C
2. Test Condition: 100 kHz, 0.1 V_{rms}
3. Saturation Current - Isat: DC current (A) that will cause L₀ to drop approximately 30%
Temperature Rise Current - I_{rms}: DC current (A) that will cause an approximate ΔT of 40°C
4. Operating temperature range includes self-temperature rise
5. Operating Temperature: -55°C to 125°C
6. The products' temperature (ambient + temp rise) should not exceed 125 °C under the worst case operating condition.
Circuit design, component, PCB trace size and thickness, airflow and other cooling provisions all could affect the operating temperature, which should be verified in the end application.

PART NUMBER KEY

F1C2 - 111110W - XXX X

Type / Product Series

F1C2 = High Power Shielded SMD Inductors

Form Factor

111103W
111106W
111110W

Inductance Tolerance

M = ±20%

Inductance *

4R7 = 4.7 µH

* Note: Inductance expressed by three figures. The unit is micro henry (µH). The first and second figures are significant digits, the third figure expresses the number of zeros which follow the two figures. If there is a decimal point, it is expressed by the capital letter "R" (3R8 = 3.8 µH). In that case, all figures are significant digits.

MECHANICAL DRAWING

Units: mm

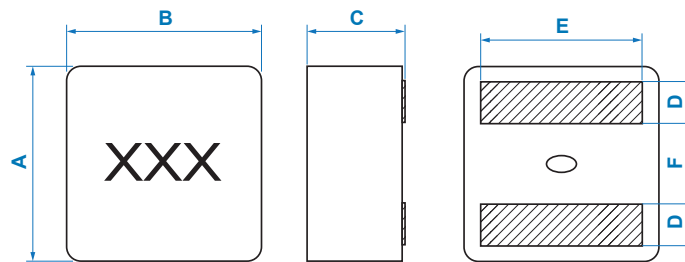

PAD LAYOUT

Units: mm

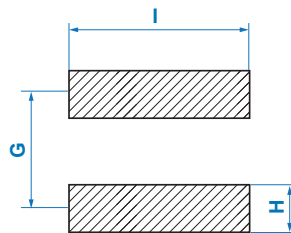

MECHANICAL DIMENSIONS (mm)

Product Series	A	B	C	D	E	F	G	H	I
F1C2-111103W	11.0 ± 0.3	11.9 ± 0.3	3.10 max	2.40 ± 0.3	9.0 ± 0.5	4.40 ± 0.5	7.10	3.40	11.0
F1C2-111106W	11.0 ± 0.3	11.9 ± 0.3	6.00 max	2.40 ± 0.3	See table	4.50 ± 0.5	7.10	3.40	11.0
F1C2-111110W	11.0 ± 0.3	11.9 ± 0.3	10.00 max	2.40 ± 0.3	See table	4.40 ± 0.5	7.10	3.40	11.0

PERFORMANCE CURVES

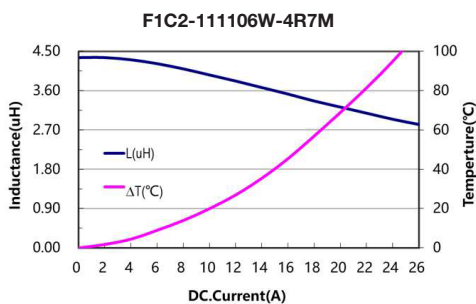
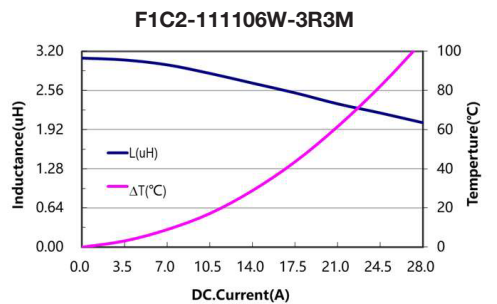
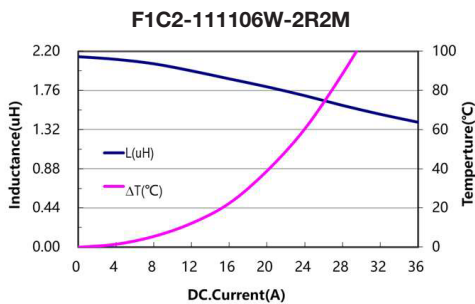
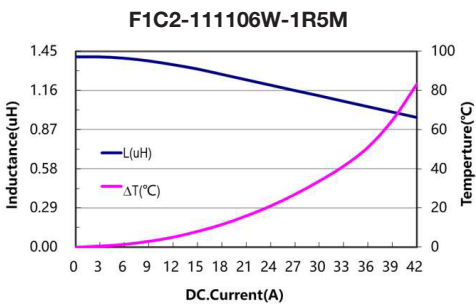
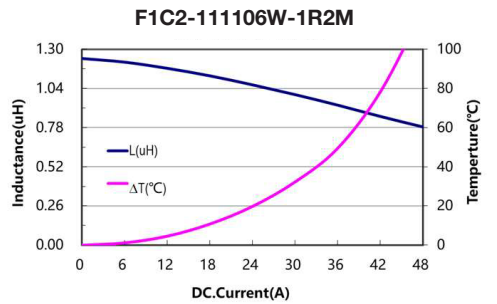
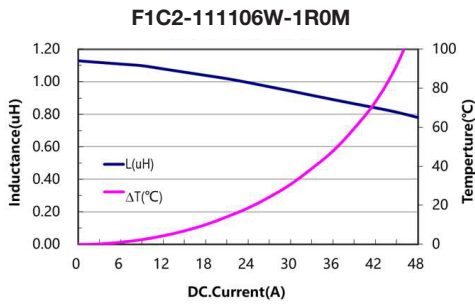
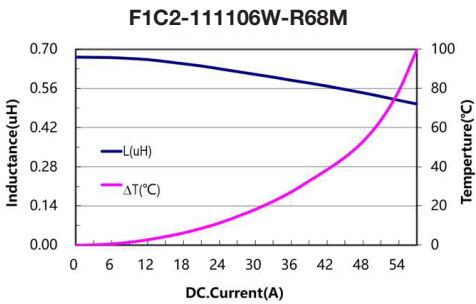
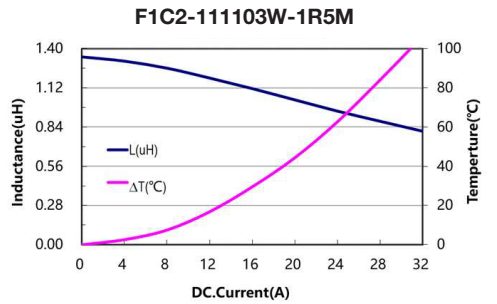
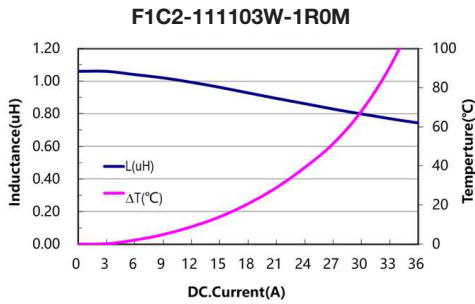
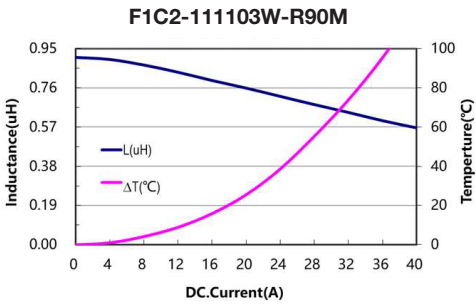
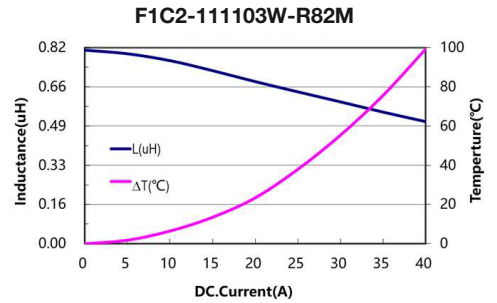
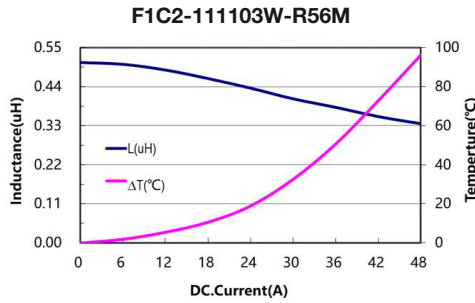
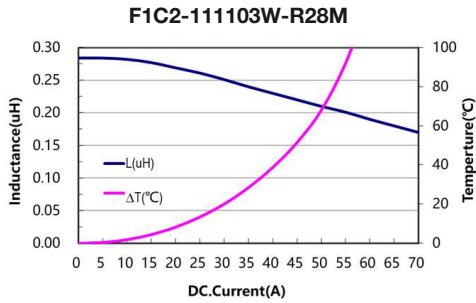

PERFORMANCE CURVES

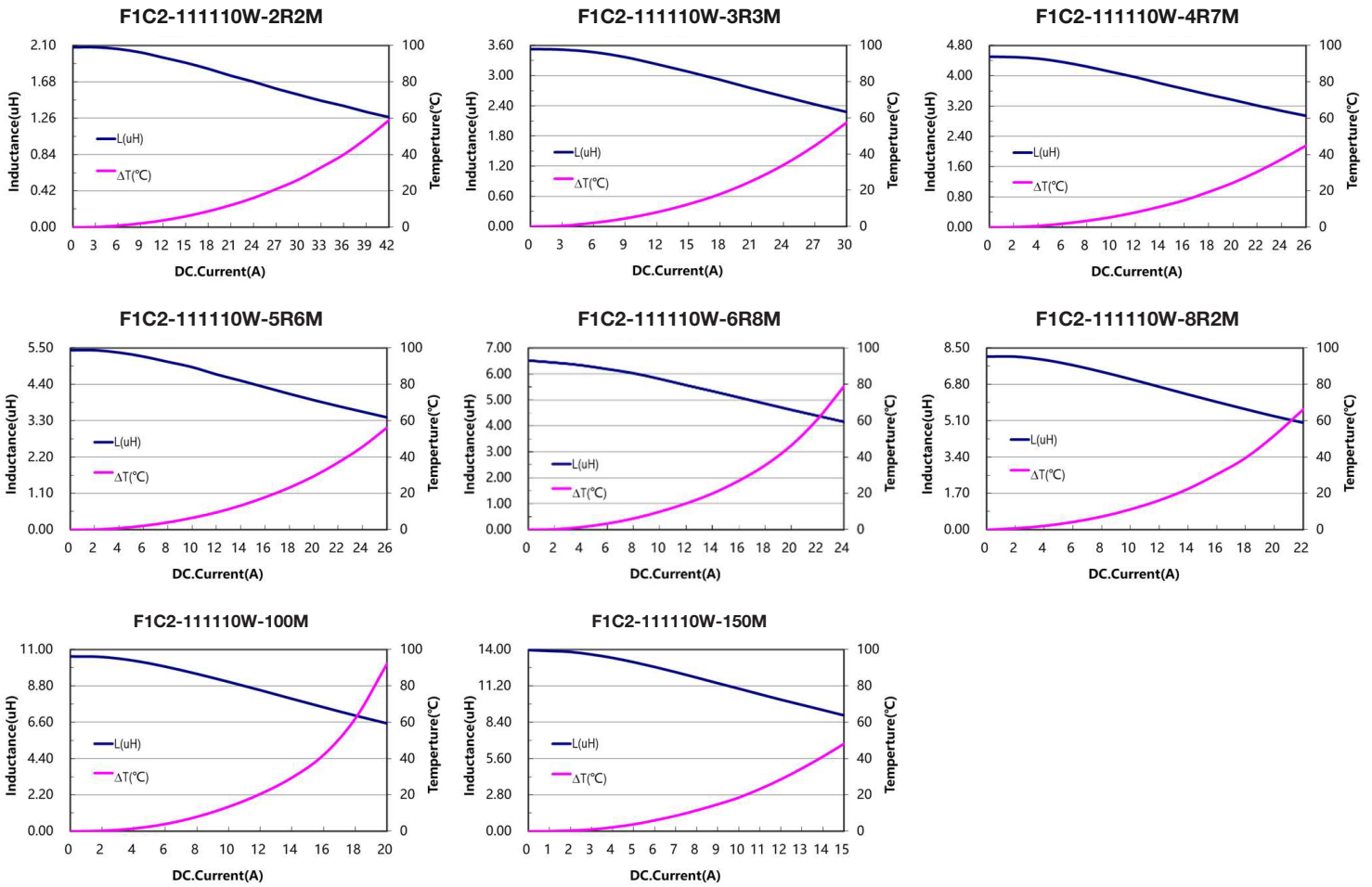

REFLOW SOLDERING TEMPERATURE CURVE

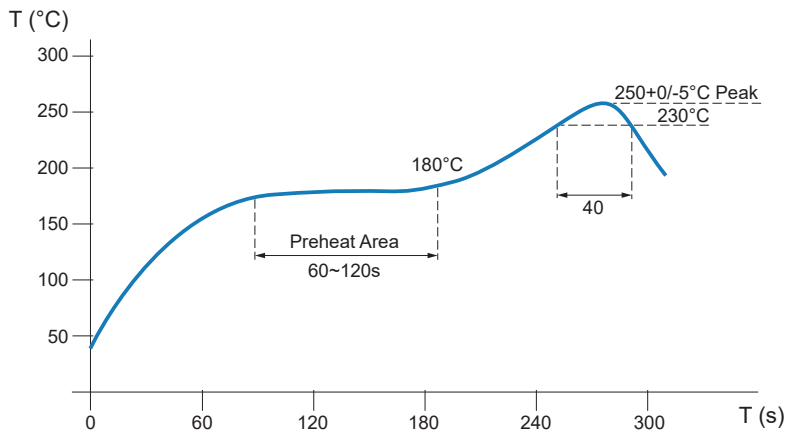

The recommended reflow conditions are set according to the soldering equipment used. Since various manufactures may have different reflow soldering equipment, products, process conditions, set methods, etc., when setting the reflow contions, please adjust and confirm according to users' environment/equipment.

QUANTITY PER REEL & PACKING INFORMATION

Units: mm

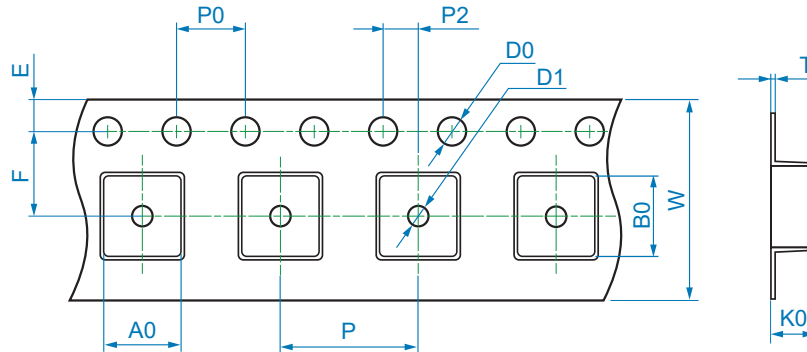

TAPE DIMENSIONS (mm)

Product Series	W	P	P0	P2	D0	D1	T	A0	B0	K0	E	F
F1C2-111103W	24 ± 0.3	16 ± 0.1	4 ± 0.1	2 ± 0.5	1.5 ± 0.1	1.5 ± 0.1	0.35 ± 0.05	12.4 ± 0.1	11.5 ± 0.1	3.3 ± 0.1	1.75 ± 0.1	11.5 ± 0.1
F1C2-111106W	24 ± 0.3	16 ± 0.1	4 ± 0.1	2 ± 0.5	1.5 ± 0.1	1.5 ± 0.1	0.35 ± 0.05	12.4 ± 0.1	11.5 ± 0.1	6.3 ± 0.1	1.75 ± 0.1	11.5 ± 0.1
F1C2-111110W	24 ± 0.3	16 ± 0.1	4 ± 0.1	2 ± 0.5	1.5 ± 0.1	1.5 ± 0.1	0.35 ± 0.05	12.4 ± 0.1	11.5 ± 0.1	10.3 ± 0.1	1.75 ± 0.1	11.5 ± 0.1

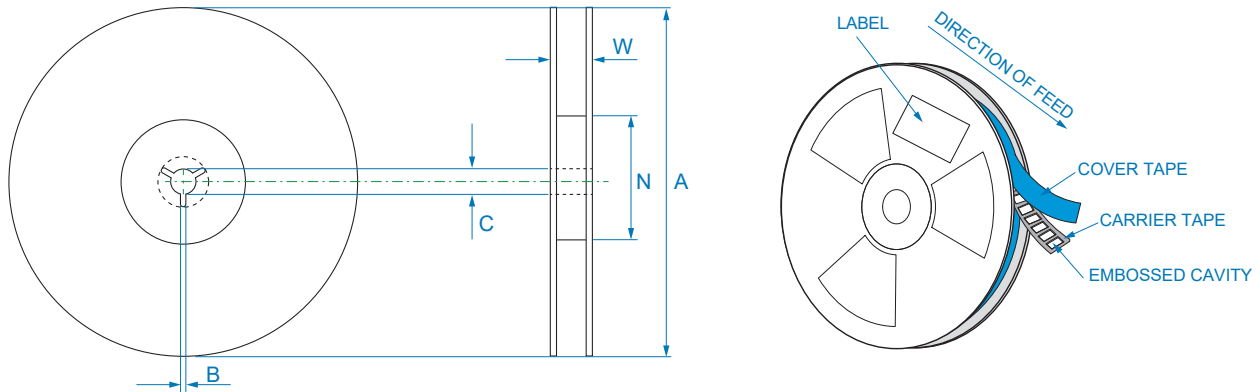

REEL DIMENSIONS (mm)

Product Series	A	W	N	B	C
F1C2-111103W	330 ± 2.0	24.0 ± 0.5	97 ± 0.5	2.2 ± 0.5	13.0 ± 0.2
F1C2-111106W	330 ± 2.0	24.0 ± 0.5	97 ± 0.5	2.2 ± 0.5	13.0 ± 0.2
F1C2-111110W	330 ± 2.0	24.0 ± 0.5	97 ± 0.5	2.2 ± 0.5	13.0 ± 0.2

Peel-off Force

The peel-off speed shall be about 300 mm/min.

The peel-off force of top cover tape shall be between 0.1 to 1.3 N

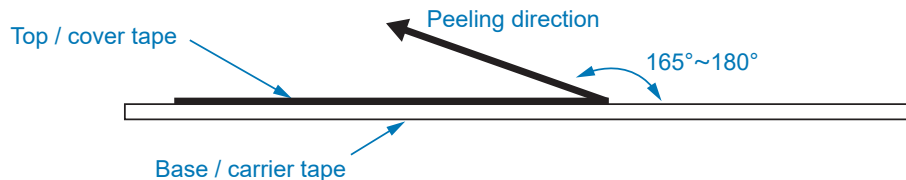

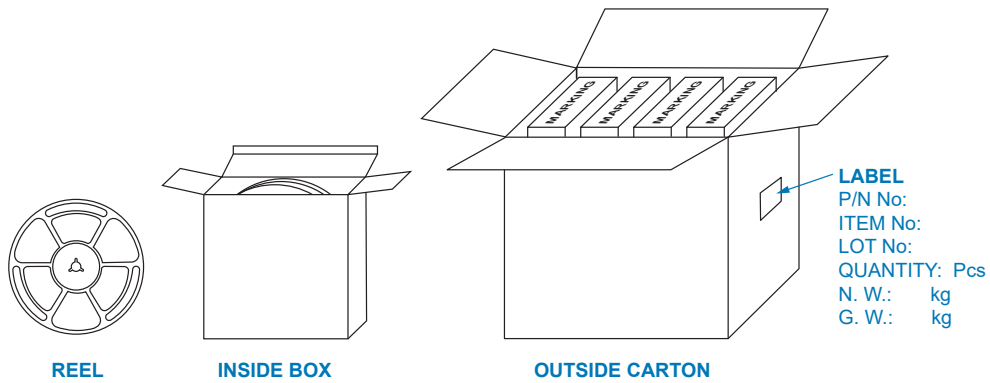

QUANTITY PER PACKAGE

Product Series	Pcs per Reel	Pcs per Inside Box	Pcs per Outside Carton
F1C2-111103W	1000	2000	8000
F1C2-111106W	500	1000	4000
F1C2-111110W	300	600	2400

Storage Conditions

- a) Temperature conditions: <35°C.
- b) Humidity conditions between 35% - 65%.
- c) Moisture Sensitivity Level (MSL): Level 1.
- d) Storage of material to be in a sulfur and chlorine free environment.

REVISION HISTORY

Rev.	Description	Date
1	initial release	May/24/2024
A		

NUCLEAR AND MEDICAL APPLICATIONS - Products are not designed or intended for use as critical components in life support systems, equipment used in hazardous environments, or nuclear control systems.

TECHNICAL REVISIONS - The appearance of products, including safety agency certifications pictured on labels, may change depending on the date manufactured. Specifications are subject to change without notice.



Bel Fuse Inc.
300 Executive Drive, Suite 300
West Orange, NJ 07052
United States

© 2024 Bel Fuse Inc.

Toll Free 866-239-5777
Tel 516-239-5777 | Fax 516-239-7208
sales@signaltransformer.com
techhelp@signaltransformer.com

belfuse.com