

THE INFORMATION CONTAINED HEREIN IS CONSIDERED "PROPRIETARY" TO BEL FUSE INC. AND SHALL NOT BE COPIED, REPRODUCED OR DISCLOSED WITHOUT THE WRITTEN APPROVAL OF BEL FUSE INC.

RoHS



LED1 POLARITY			LED2 POLARITY			
PIN 13	PIN 14	COLOR	PIN 15	PIN 16	PIN 17	COLOR
-	+	YELLOW	-	+	/	ORANGE
/	/	/	/	+	-	GREEN

ELECTRICAL CHARACTERISTICS @ 25°C

TURNS RATIO

TP1	1CT : 1CT ±2%
TP2	1CT : 1CT ±2%
TP3	1CT : 1CT ±2%
TP4	1CT : 1CT ±2%
QCL @ 100kHz/100mVRMS	(0-70 Deg. C)
8mA DC BIAS	350µH MIN.
INS. LOSS	
0.1MHz TO 1MHz	-1.1 dB MAX
1MHz TO 65MHz	-0.5 dB MAX
65MHz TO 100MHz	-0.8 dB MAX
100MHz TO 125MHz	-1.2 dB MAX
RET. LOSS (MIN) @ 100 OHMS +/-15%	
0.5MHz-40MHz	-18 dB
40MHz-100MHz	-12+20LOG(f/80MHz) dB
CM TO CM REJ	
100kHz - 100MHz	-30 dB MIN
CM TO DM REJ	
100kHz - 100MHz	-35 dB MIN
HIPOT (Isolation Voltage):	1500 Vrms
100% OF PRODUCTION TESTED TO COMPLY WITH IEEE 802.3 ISOLATION REQUIREMENTS.	

LED 1	
VF (FORWARD VOLTAGE)	IF=20mA YELLOW 2.1V TYP.
λD (DOMINANT WAVELENGTH)	IF=20mA YELLOW 590nm TYP.
LED 2	
VF (FORWARD VOLTAGE)	IF=20mA GREEN 2.2V TYP.
	ORANGE 2.1V TYP.
λD (DOMINANT WAVELENGTH)	IF=20mA GREEN 570nm TYP.
	ORANGE 605nm TYP.

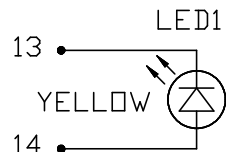

SCHEMATIC

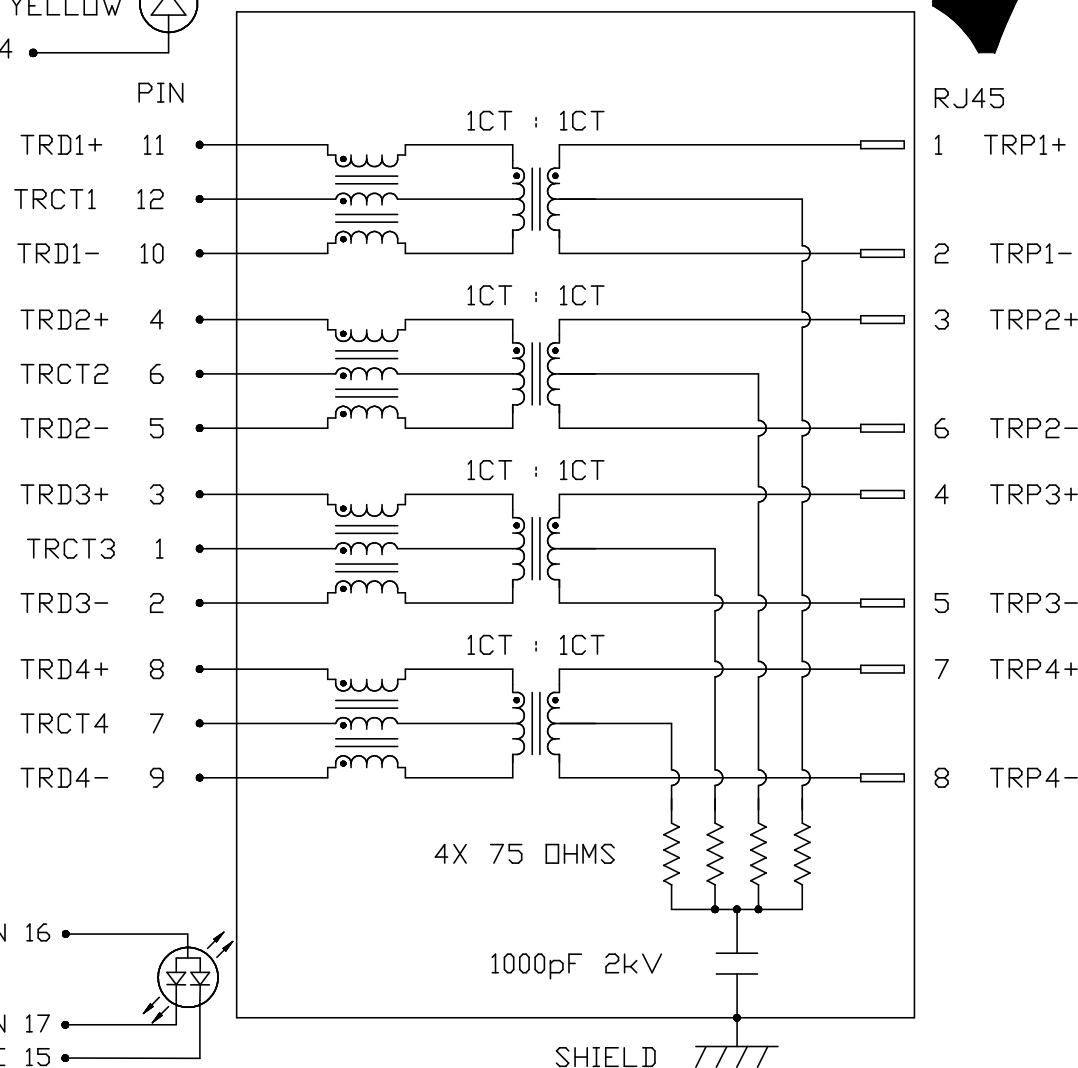

- RJ45
- 1 TRP1+
 - 2 TRP1-
 - 3 TRP2+
 - 6 TRP2-
 - 4 TRP3+
 - 5 TRP3-
 - 7 TRP4+
 - 8 TRP4-

REV. : K PAGE : 2

ORIGINATED BY
CHOW WANCHUNG
DATE 2015-01-28

DRAWN BY
HU XIANG
DATE 2015-01-28

TITLE
gigabit MagJack®
(Ultra Low Profile)
PATENTED

PART NO. / DRAWING NO.
L829-1J1T-43

FILE NAME
L829-1J1T-43_K.DWG

STANDARD DIM. [] METRIC DIM.
TOL. IN INCH AS REF.

.X UNIT : INCH [mm]
.XX SCALE : N/A
.XXX SIZE : A4



THE INFORMATION CONTAINED HEREIN IS CONSIDERED "PROPRIETARY" TO BEL FUSE INC. AND SHALL NOT BE COPIED, REPRODUCED OR DISCLOSED WITHOUT THE WRITTEN APPROVAL OF BEL FUSE INC.

MECHANICAL SPECIFICATION

RoHS

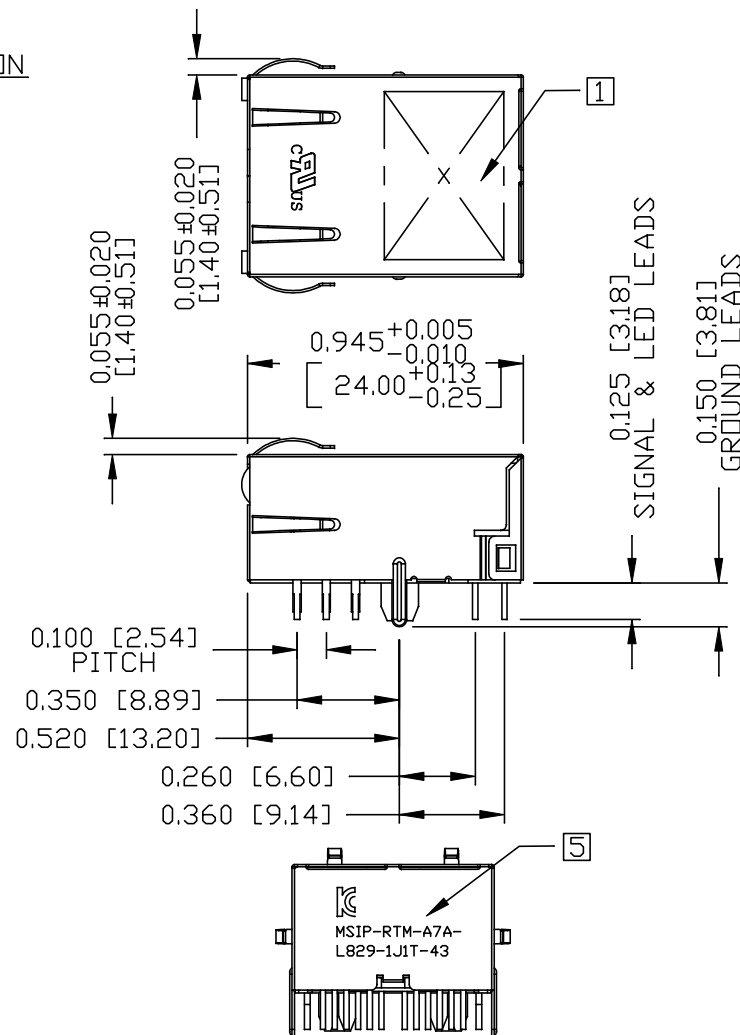
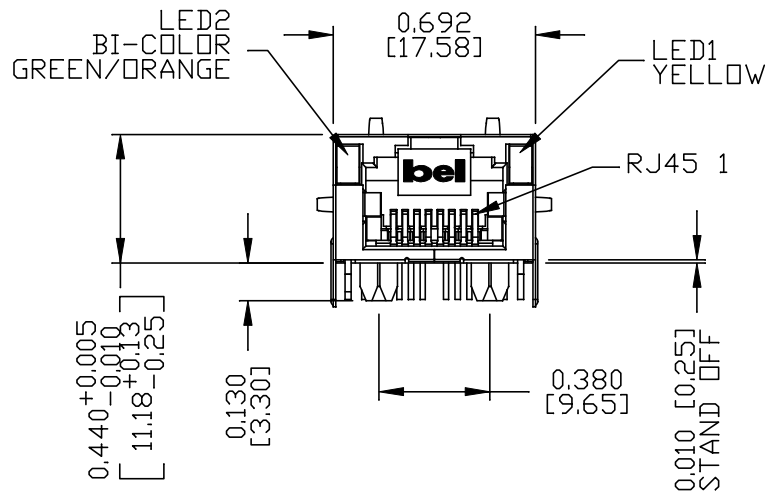

BACK VIEW

NOTES:

- 1. PLASTIC HOUSING: THERMOPLASTIC PA. FLAMMABILITY RATING UL 94V-0
- CONTACTS: 30 MICRO-INCH HARD GOLD PLATING OR EQUIVALENT.
- OUTPUT PINS: TIN-COATED COPPER WIRE, DIA 0.018 INCH.
- METAL SHIELD: NICKEL PLATED ON COPPER ALLOY. (ALL GROUND LEADS ARE SOLDER DIPPED)
- [1] MARK PART WITH MFG. LOGO, MFG. NAME, PART NUMBER, DATE CODE AND PATENTED.
- 2. THE PRODUCT IS RoHS COMPLIANT.
- 3. UL RECOGNIZED - FILE #E196366 AND E169987.
- 4. JACK CAVITY CONFORMS TO FCC RULES AND REGULATIONS, PART 68 SUBPART F.
- 5. THE PRODUCT IS PATENTED. THE PATENT NUMBER ARE

U.S. PAT. 5,736,910 AND U.S. PAT. 7,123,117 AND U.S. PAT. 6,840,817.

[5] MARK PART WITH KCC LOGO AND ID ON THE BACK SURFACE.

ORIGINATED BY
LI QUANKUN
DATE 2015-01-28
DRAWN BY
ZHANG XUEZHENG
DATE 2015-01-28

TITLE
gigabit MagJack®
(Ultra Low Profile)
PATENTED

PART NO. / DRAWING NO.
L829-1J1T-43
FILE NAME
L829-1J1T-43_K.DWG

STANDARD DIM. TOL. IN INCH	[] METRIC DIM. AS REF.
.X	UNIT : INCH [mm]
.XX	SCALE : N/A
.XXX	SIZE : A4

REV. : K PAGE : 3



THE INFORMATION CONTAINED HEREIN IS CONSIDERED "PROPRIETARY" TO BEL FUSE INC. AND SHALL NOT BE COPIED, REPRODUCED OR DISCLOSED WITHOUT THE WRITTEN APPROVAL OF BEL FUSE INC.

RoHS



RECOMMENDED PCB FOOTPRINT

COMPONENT SIDE VIEW

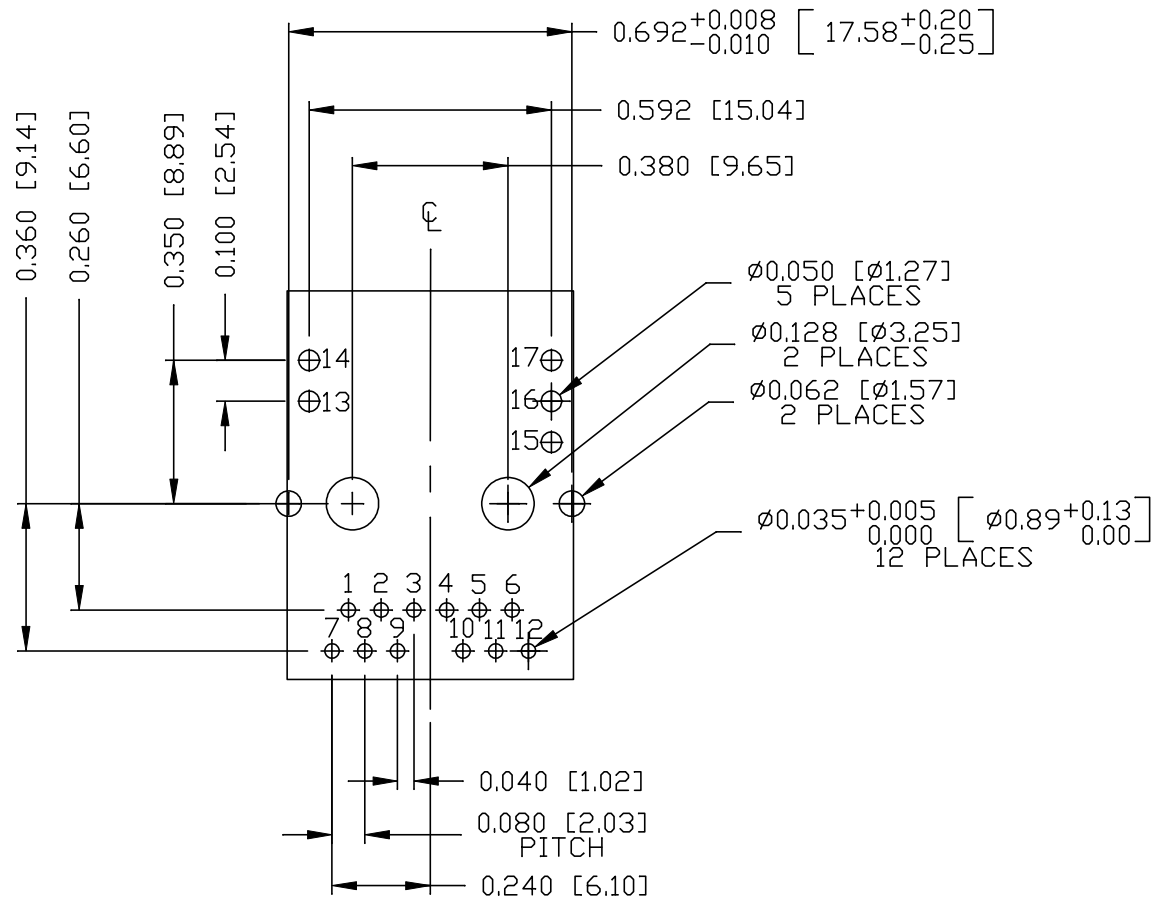

REV. : K PAGE : 4

ORIGINATED BY
LI QUANKUN
DATE 2015-01-28
DRAWN BY
ZHANG XUEZHENG
DATE 2015-01-28

TITLE
gigabit MagJack®
(Ultra Low Profile)
PATENTED

PART NO. / DRAWING NO.
L829-1J1T-43
FILE NAME
L829-1J1T-43_K.DWG

STANDARD DIM. TOL. IN INCH	[] METRIC DIM. AS REF.
.X	UNIT : INCH [mm]
.XX	SCALE : N/A
.XXX	±0.004
	SIZE : A4



THE INFORMATION CONTAINED HEREIN IS CONSIDERED "PROPRIETARY" TO BEL FUSE INC. AND SHALL NOT BE COPIED, REPRODUCED OR DISCLOSED WITHOUT THE WRITTEN APPROVAL OF BEL FUSE INC.

RoHS



SUGGESTED PANEL OPENING

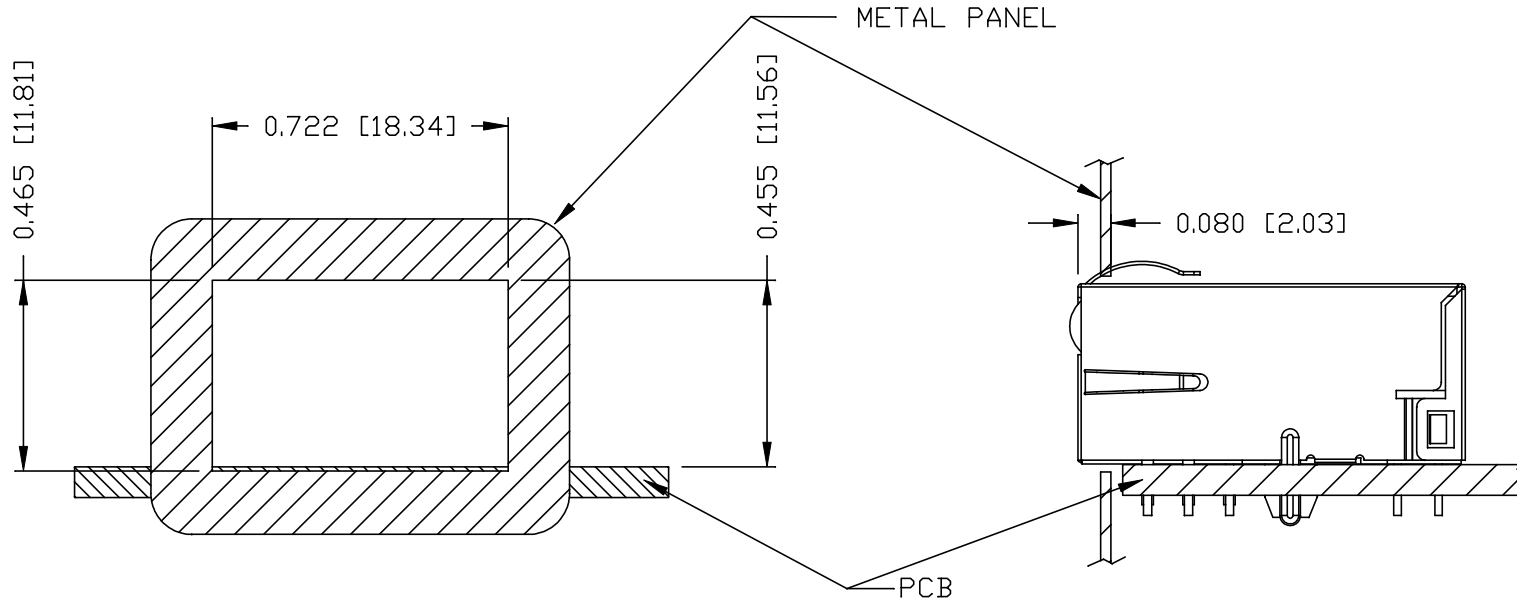

NOTE:

THE DISTANCE OF PANEL INSIDE SURFACE RELATIVE TO FRONT SURFACE OF PART IS ONLY A SUGGESTION. IN CASE THIS DISTANCE IS DIFFERENT, THE REQUIRED PANEL OPENING DIMENSIONS CHANGE ACCORDINGLY.

TRAY PACKING INFORMATION

PACKING TRAY : 0200-9999-E4 (TOP)
0200-9999-E5 (BOTTOM)

PACKING QUANTITY : 60 PCS FINISHED GOODS PER TRAY
11 TRAYS (660 PCS FINISHED GOODS) PER CARTON BOX

NOTE : CARDBOARDS ARE PLACED BETWEEN LAYERS OF PACKING TRAY INSIDE CARTON BOX
(INCLUDE THE UPPERMOST AND LOWERMOST TRAY)

REV. :	K	PAGE :	5
--------	---	--------	---

ORIGINATED BY LI QUANKUN DATE 2015-01-28 DRAWN BY ZHANG XUEZHENG DATE 2015-01-28	TITLE gigabit MagJack® (Ultra Low Profile) PATENTED	PART NO. / DRAWING NO. L829-1J1T-43	STANDARD DIM. TOL. IN INCH .X	[] METRIC DIM. AS REF. UNIT : INCH [mm]	
		FILE NAME L829-1J1T-43_K.DWG	.XX	SCALE : N/A	
		.XXX ±0.004		SIZE : A4	

THE INFORMATION CONTAINED HEREIN IS CONSIDERED "PROPRIETARY" TO BEL FUSE INC. AND SHALL NOT BE COPIED, REPRODUCED OR DISCLOSED WITHOUT THE WRITTEN APPROVAL OF BEL FUSE INC.

RoHS



TAPE AND REEL PACKING INFORMATION

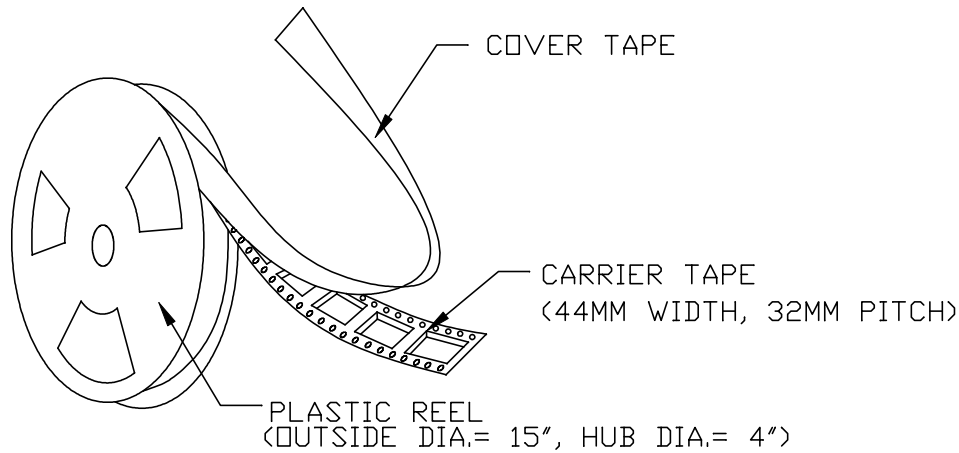

USER FEED DIRECTION

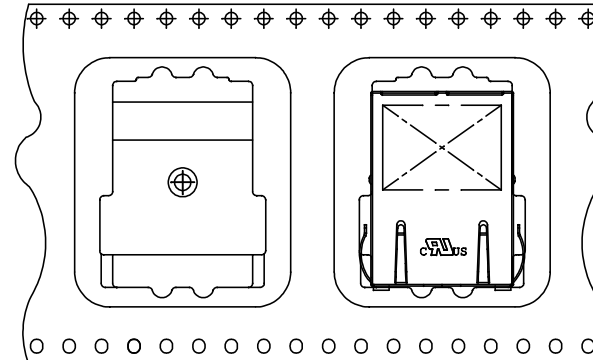

PART ORIENTATION & FEEDING DIRECTION.

NOTES:

- 1) LEAVES 48 INCHES COVER TAPE AND 10 EMPTY POCKETS AT TRAILER.
- 2) LEAVES 24 INCHES COVER TAPE AND 13 EMPTY POCKETS AT LEADER.
- 3) PACK 140 PCS PER REEL.
- 4) EACH PIZZA BOX CONTAINS ONE (1) REEL. (140 PCS FINISHED GOODS EACH PIZZA BOX).
- 5) EACH OUTER CARTON CONTAINS SIX (6) PIZZA BOXES. (840 PCS FINISHED GOODS EACH OUTER CARTON).

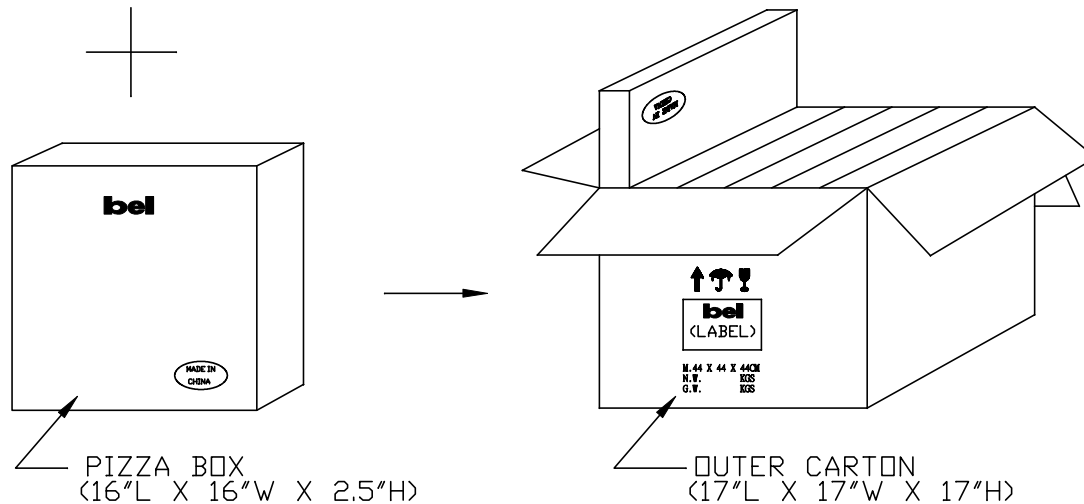

REV. : K PAGE : 6

ORIGINATED BY LI QUANKUN DATE 2015-01-28	TITLE gigabit MagJack® (Ultra Low Profile) PATENTED	PART NO. / DRAWING NO. L829-1J1T-43	STANDARD DIM. TOL. IN INCH	[] METRIC DIM. AS REF.	
DRAWN BY ZHANG XUEZHENG DATE 2015-01-28		FILE NAME L829-1J1T-43_K.DWG	.X .XX .XXX	UNIT : INCH [mm] SCALE : N/A SIZE : A4	
DC002(2)120214		This document is electronically generated. This is a controlled copy if used internally			

THE INFORMATION CONTAINED HEREIN IS CONSIDERED "PROPRIETARY" TO BEL FUSE INC. AND SHALL NOT BE COPIED, REPRODUCED OR DISCLOSED WITHOUT THE WRITTEN APPROVAL OF BEL FUSE INC.

RoHS



DIMENSION CHART					
Ao	Bo	Ko	P1	So	LENGTH/22" REEL
0.713 [18.10]	0.965 [24.51]	0.657 [16.69]	1.260 [32.00]	1.591 [40.40]	11 METERS

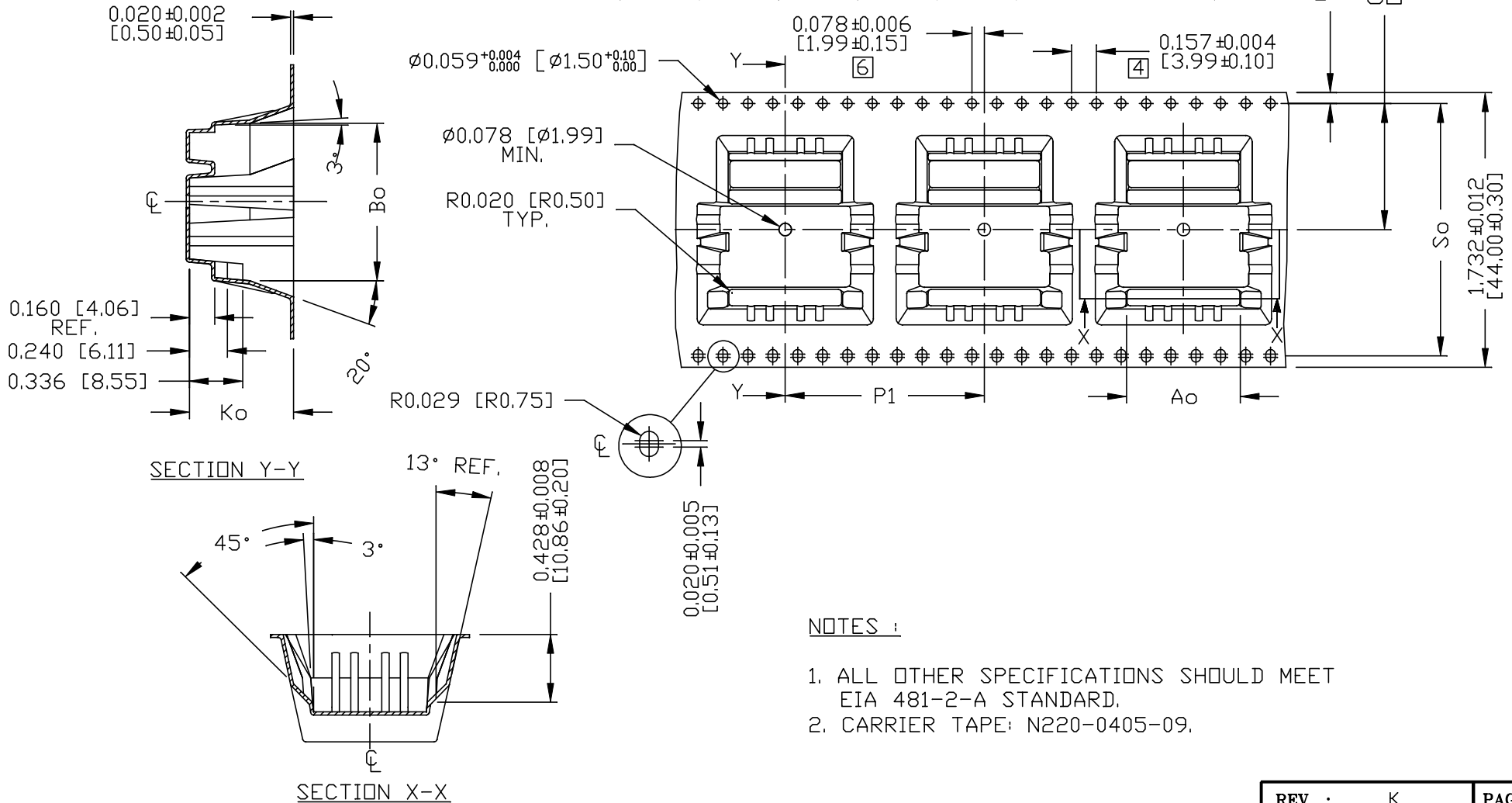

NOTES :

1. ALL OTHER SPECIFICATIONS SHOULD MEET EIA 481-2-A STANDARD.
2. CARRIER TAPE: N220-0405-09.

REV. :	K	PAGE :	7		
<p>a bel group</p>					
				STANDARD DIM. TOL. IN INCH	[] METRIC DIM. AS REF.
				.X	UNIT : INCH [mm]
				.XX	SCALE : N/A
.XXX	±0.004	SIZE : A4			

ORIGINATED BY
LI QUANKUN
DATE 2015-01-28

DRAWN BY
ZHANG XUEZHENG
DATE 2015-01-28

TITLE
gigabit MagJack®
(Ultra Low Profile)
PATENTED

PART NO. / DRAWING NO.
L829-1J1T-43

FILE NAME
L829-1J1T-43_K.DWG

STANDARD DIM. TOL. IN INCH

[] METRIC DIM. AS REF.

UNIT : INCH [mm]

SCALE : N/A

SIZE : A4